

Simpson[®] Century, Round, Rectangular, and Wide-Vue Styles

Elapsed Time Meters

- Records the "On" Time of Electrical Equipment AC & DC Operating Voltage Units
- Phenolic Cases With Glass Windows
- Six Attractive Case Styles
- Two Popular Sizes: 1-1/2", 3-1/2"

Simpson's series of elapsed time meters features a six-digit readout with no reset capability, making them virtually tamper proof. Each true-time elapsed time meter is ruggedly constructed and records the "on" time of electrical equipment. They are widely used in factory environments where there is a need to accumulate running time and monitor life and performance records on AC and DC powered equipment. All hour meters are connected in parallel with the equipment being monitored. The synchronous motor provides accurate hour indication. Model 109ET has a 10-80 V DC input as a standard feature. An optional plug-in AC converter module can also be ordered with the model 109 ET. Choose from Century, Wide-Vue, Rectangular or Round case styling to match other instruments.



Model 2153ET
Century



Model 112ET



Model 109ET



Model 55ET
Round



Model 1357ET
Wide-Vue



Model 57ET
Rectangular

Dimensions

1 = Panel Meter Cut-out Dimensions

1-1/2" - Model 109ET

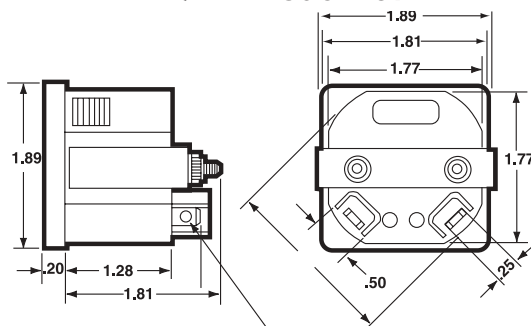

MALE QUICK CONNECT TERMINAL, 1/4" TAB
(1/4" WIDE X .032" THK. X 312 LNG.)

3-1/2" - Model 55ET

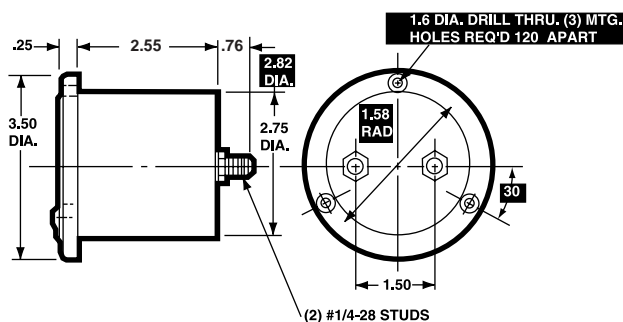

Model Number	Size	Meter Movement
109ET	1-1/2"	Clock Motor
112ET	1-1/2"	
55ET	3-1/2"	
1357ET	3-1/2"	
57ET	3-1/2"	
2153ET	3-1/2"	

Dimensions

1 = Panel Meter Cut-out Dimensions

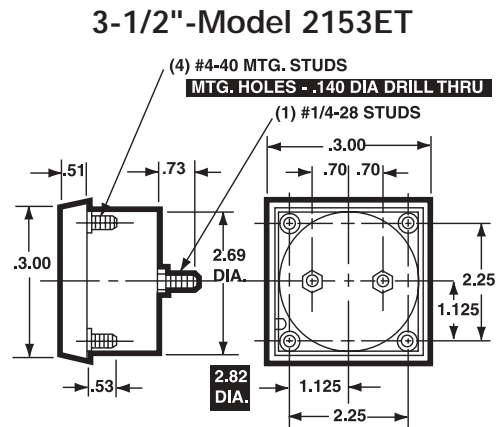
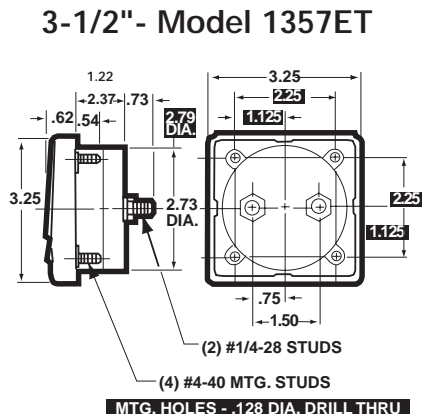
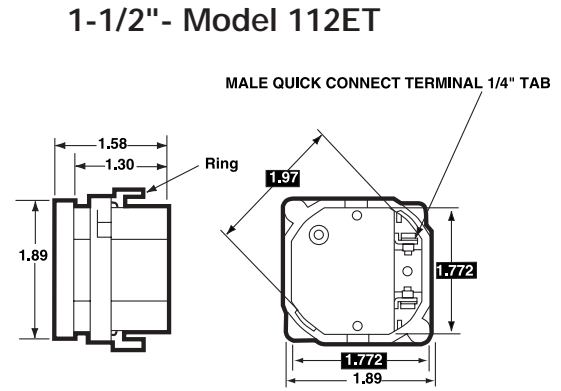
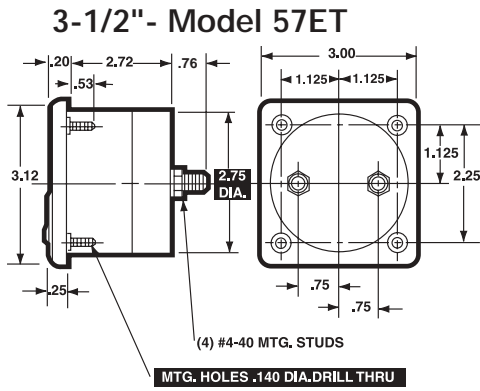

Specifications

Accuracy:	Model 109ET & 112ET: <.01%/24 HRS. Models 55ET, 1357ET, 57ET, 2153: synchronous with AC power
Movement:	Synchronous clock motor
Overload(1 sec):	10 times F.S.
Maximum Indication:	99,999.9 Hours
Power Consumption:	Models 109ET, 112ET: .5 watts All Other Models: 2.5 watts

Case:	Models 55ET, 57ET, 2153ET: High density phenolic Models 109ET, 112ET, 1357ET: High density black acrylic
Operating Temperature:	-4°F to +149°F (-20°C to +65°C)
Net Weight:	Models 112ET, 109ET: 2.5 oz (0.07kg) Models 55ET, 57ET: 12.5 oz (0.35kg) Model 1357ET, 2153ET: 13 oz (0.37kg)

Ordering Information

Elapsed Time

Operating Voltage (6 10)	Maximum Indication (hours)	Power Consumption	Accuracy	Model Size	Model Number	Catalog Number
10-80 VDC*	99,999.9	.5 watts	≤.01%/24 hrs	1-1/2"	109ET	03618
120 VAC	99,999.9	.5 watts	≤.01%/24 hrs	1-1/2"	112ET	03622
120 VAC 60 Hz	99,999.9	2.5 watts	synchronous	3-1/2"	55ET	03580
	99,999.9	2.5 watts	synchronous		1357ET	03595
	99,999.9	2.5 watts	synchronous		57ET	03590
	99,999.9	2.5 watts	synchronous		2153ET	17720
240 VAC 60 Hz	99,999.9	2.5 watts	synchronous	3-1/2"	55ET	03600
	99,999.9	2.5 watts	synchronous		57ET	03610
	99,999.9	2.5 watts	synchronous		1357ET	03615
	99,999.9	2.5 watts	synchronous		2153ET	17721

* Model 109ET has 10-80 VDC input-standard, or 100-265 VAC, 50-1000 Hz with optional plug-in AC converter module, Cat. No. 03619.

Function Reference Table

For your convenience, the table below lists Century, Round and Rectangular models for other electrical monitoring functions and page reference.

Function	Style		
	Century	Round	Rectangular
AC Current	E15	E17	E19
AC Voltage	E35	E37	E39
DC Current	E55	E57	E59
DC Voltage	E75	E77	E79
Percent Motor Load	E99	E91	-
Watts	E107	E109	E111
Process	E113	E115	E115