

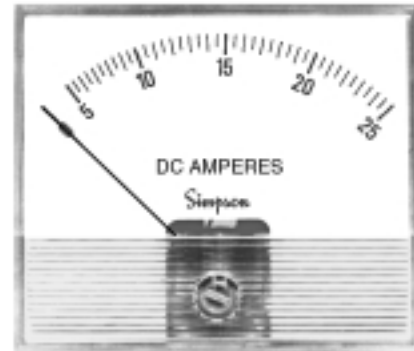

- Clear, Acrylic Windows
- Optional Bezel Kits
- Special Colored Scales or Logos Available
- ±2% Full Scale Accuracy
- Five Popular Sizes: 1-1/2", 2-1/2", 3-1/2", 4-1/2",



Model Number	Size	Meter Movement
921	1-1/2"	Annular
922	2-1/2"	Annular
923	3-1/2"	Annular
924	4-1/2"	Annular
926	4" x 6"	Annular

Simpson's Tru-View family of analog panel meters offers a modern, clear acrylic front lens, and a clean, open scale to update your panel design. Tru-View panel meters provide reliable measurement of DC current up through 500 amps and are available in five popular sizes including: 1-1/2", 2-1/2", 3-1/2", 4-1/2", and 4x6" sizes. High range inputs require external current shunts (see Accessory Section). All meters are guaranteed to ±2% full scale (F.S.) accuracy and meet

American National Standards Institute specification ANSI C39.1. Attractive black satin, die cast bezels are available in 3-1/2 and 4-1/2 inch sizes for behind panel mounting. The annular movement with rugged spring-backed pivot and jewel or taut band suspensions is self-shielded from stray magnetic fields. This style meter is ideal for many other electrical functions. See the "Function Reference Table."

Dimensions and Compatibility

1 = Panel Meter Cut-out Dimensions

1-1/2"-Model 921

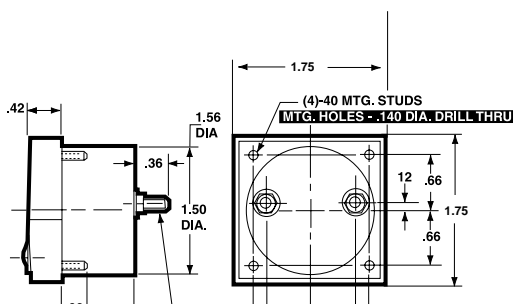

2-1/2"-Model 922

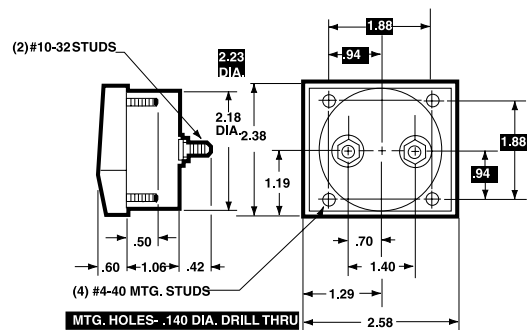

3-1/2"-Models 923

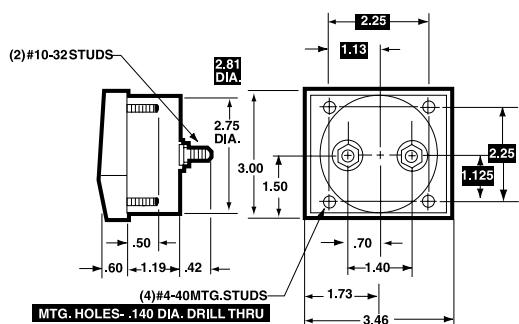

4-1/2"-Model 924

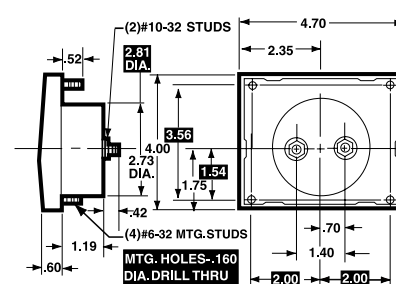

Dimensions and Compatibility cont.

4x6"-Models 926

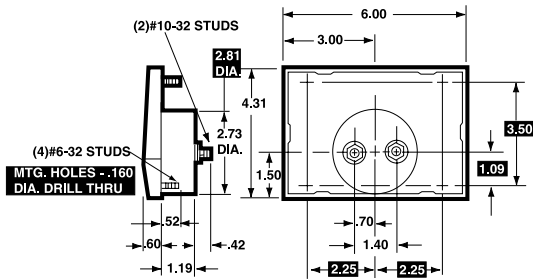

Compatibility Reference Table

Manufacturer	Size/Model			
	1-1/2"	2-1/2"	3-1/2"	4-1/2"
Beede		2-PL	3-01	14
Crompton Celebrity		223	225	227
Challenger	361	362	363	364
Clearvu		233	235	237
Hoyt 3100	3115	3125	3135	3145
Custom	2015	2025	203	2045
Window	3115W	3125W	3135W	5
Modutec S Series				
PB Series	1PB-	2PB-*	3PB-*	4PB
Triplet G Series	120-G	220-G	320-G	420-G
Weston 2000 Series		2021	2031	2041
Yokogawa Horizon	251-1XX	251-2XX	251-3XX	251-4XX

*Modutec uses a three-stud mount.

Specifications

Accuracy:	±2% F.S.
Movement:	Annular, self-shielding
Suspension:	Pivot and jewel or taut band
Tracking:	±3%
Response Time:	1.5 seconds maximum above 10mA.
Overload (1 sec.)	10 times F.S.
Overload (Continuous):	1.5 times F.S.
Shielding:	Calibration is unaffected by stray magnetic field or panel mounting.
Repeatability:	2% Pivot and jewel; 0.5% Taut band
Dial:	Sharp clear scale. Each dial arc is calibrated to track the specific type of movement used.
Operating Temperature:	-4°F to +149°F (-20°C to +65°C)

Resistance:	±15%
Case:	High density clear plastic
Pointer:	Knife-edge, black matte finish
Scale Length:	Model 921: 1.56" (39.62mm) Mode 922: 2.40" (60.96mm) Mode 923: 3.27" (83.06mm) Mode 924: 3.92" (99.67mm) Mode 926: 5.45" (138.43mm)
Net Weight:	Model 921: 1.5oz (.04kg) Model 922: 4oz (.11kg) Model 923: 6oz (.17kg) Model 924: 8oz (.22kg) Model 926: 12oz (.34kg)

Ordering Information

TV — **1** — **DMA** — **050**

Size — **1** — **Function** — **Range**

1	1-1/2"
2	2-1/2"
3	3-1/2"
4	4-1/2"
6	4 x 6"

DC

Millimeter (Pivot and Jewel)

Range	≈ ohms
DMA001	0-1 DCmA 43
DMA003	0-3 DCmA 2.0
DMA005	0-5 DCmA 2.0 (20)*
DMA010	0-10 DCmA 10.0 (2.2)*
DMA015	0-15 DCmA 6.6 (2.2)*
DMA020	0-20 DCmA 5.0
DMA025	0-25 DCmA 4.0 (6.0)*
DMA050	0-50 DCmA 2.0 (3.0)*
DMA100	0-100 DCmA 1.0 (1.5)*
DMA150	0-150 DCmA 0.66(1.0)*
DMA200	0-200 DCmA 0.50 (.75)*
DMA250	0-250 DCmA 0.40 (.60)*
DMA300	0-300 DCmA 0.33 (.50)*
DMA500	0-500 DCmA 0.20 (.30)*
DMA750	0-750 DCmA 0.13

*Resistance for 1-1/2" sizes shown in ()

Microammeter (Taut Band)

Range	≈ ohms
TUA010	0-10 DCμA 4900
TUA015	0-15 DCμA 1960 (5500)*
TUA025	0-25 DCμA 1960
TUA050	0-50 DCμA 960
TUA100	0-100 DCμA 500
TUA200	0-200 DCμA 234

DCμA, T.B.: 1-1/2" size only available for ranges 50μA and above, 4x6" size only available for ranges 100μA and above.

*Resistance for 1-1/2" sizes shown in ()

Microammeter (Pivot and Jewel)

Range	≈ ohms
DUA100	0-100 DCμA 1800
DUA200	0-200 DCμA 1100
DUA500	0-500 DCμA 90 (190)*
DUA1H1	100-0-100 DCμA 1100
DUA5H5	500-0-500 DCμA 43

*Resistance for 1-1/2" sizes shown in ()
DCμA, P&J: 0-50 DCμA range not available in 4x6" size.

*1-1/2" sizes only - 10 ohms
External current shunts (not included), 50mV drop, are required with 1-1/2" DC meters, above 10 amps; and on 2-1/2", 3-1/2" and 4x6" DC meters above 50 amps.

Current meter (Pivot and Jewel)

Range	≈ ohms
DAA001	0-1 DCA 0.050
DAA002	0-2 DCA 0.025
DAA003	0-3 DCA 0.0166
DAA005	0-5 DCA 0.010
DAA010	0-10 DCA 0.005
DAA015	0-15 DCA 0.0033*
DAA020	0-20 DCA 0.0025*
DAA025	0-25 DCA 0.0020*
DAA030	0-30 DCA 0.0017*
DAA050	0-050 DCA 0.001*
DAA100	0-100 DCA 10.0*
DAA150	0-150 DCA 10.0*
DAA200	0-200 DCA 10.0*
DAA300	0-300 DCA 10.0*
DAA500	0-500 DCA 10.0*
DAA5T5	50-0-50 DCA 0.001

Accessories

External Portable and Switchboard Shunts

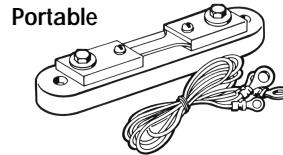
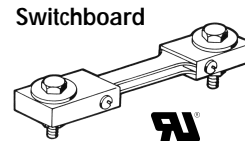

External shunts enable Tru-View style panel instruments to indicate higher DC current ranges. Either a portable or switchboard shunt is installed in series with the load and the source. They provide a DCmV drop which is sent to the Tru-View instrument. Simpson's external shunts are available for immediate delivery from your local distributor. Other intermediate ranges are available at minimum quantities on special order.

Each shunt includes 5' leads (0.065 V Resistance).

Switchboard Shunts (50mV)

Amps	Cat. Number
100	06500
150	06503
200	06504
250	06505
300	06506
400	06507
500	06508

Portable Shunts (50mV)

Amps	Cat. Number
1	06700
5	06703
10	06704
15	06705
25	06707
30	06708
50	06709
75	06711
100	06713
150	06714
200	06715

Portable Shunts (100mV)

Amps	Cat. Number
10	06716
100	06717

NOTE: 5' leads not included

Function Reference Table

For your convenience, the table below lists Tru-View models for other electrical monitoring functions with page number reference.

Function	Section	Page
AC Current	E	13
AC Voltage	E	33
DC Voltage	E	73