

ēno goes mobile

Get interactive whiteboard power right in your hands.

ēno mini lets you create and deliver engaging lessons from anywhere in the classroom.

ēno mini is the mobile companion to the ēno interactive whiteboard and offers all the same features, benefits and environmental certifications, but provides even more flexibility. Teachers can magnetically detach ēno mini from a ceramicsteel surface and move freely about the room.

Using the same revolutionary Bluetooth®-enabled stylus, teachers and students can effortlessly collaborate on lessons by simultaneously using up to three styluses on ēno mini slates and ēno interactive whiteboards.

Even without an interactive whiteboard, ēno mini can transform any classroom with a projector and computer into a dynamic and interactive learning environment.



Features

- Multi-user input—up to three users can simultaneously interact on ēno mini and/or ēno interactive whiteboards
- Durable—rugged grip surface is virtually indestructible and can withstand the rigors of any classroom
- Slate has no battery to charge and no electronics to fail
- Ergonomic design—comfortable to hold and lightweight
- Antimicrobial product protection—prevents bacteria and fungal growth on the surface of the product*
- Convenient storage—attaches magnetically to any steel surface including most markerboards and chalkboards
- Environmentally certified—Cradle-to-CradleSM Silver and SCS Indoor Advantage Gold certified
- Low total cost of ownership—sharing the stylus with an ēno interactive whiteboard lowers total cost. Identical user interface between ēno mini and ēno interactive whiteboard also minimizes training expenses
- Forever Warranty™—durable and long-lasting ceramicsteel surface that lasts a lifetime



Create and deliver engaging lessons from anywhere in the classroom with ēno mini.

PolyVision®

a steelcase company

technical specifications

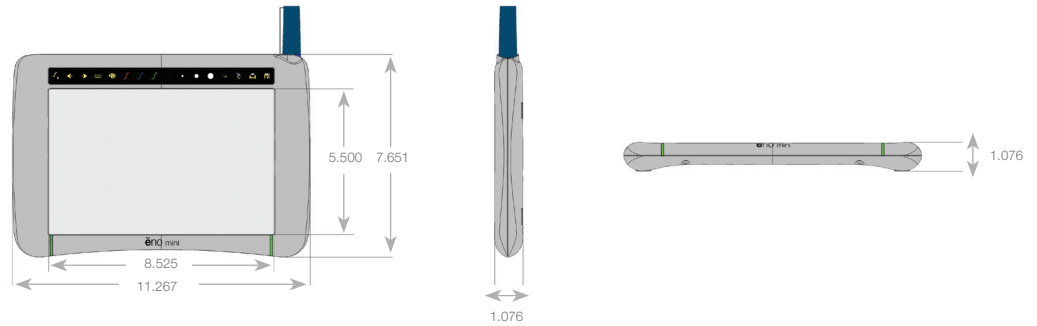

Model Selector Guide

ēno mini model	Includes	Ideal for...	What do I need to use the slate?	Important usage notes
ēno 2110	<ul style="list-style-type: none"> Slate PolyVision driver software <p>* Does not include a stylus</p>	<ul style="list-style-type: none"> Teachers to better monitor and support student engagement by roaming the classroom while driving the lesson 	<ul style="list-style-type: none"> Computer ēno interactive whiteboard Projector 	<ul style="list-style-type: none"> Slate use is dependent on sharing the stylus and Bluetooth radio dongle that came with the ēno interactive whiteboard For added student control, an ēno accessory stylus is available For room-to-room mobility, a complete ēno stylus kit is available
ēno 2120	<ul style="list-style-type: none"> Slate Stylus AAA battery PolyVision driver software 	<ul style="list-style-type: none"> Teacher and student lesson interaction Writing on the eno board while a student responds using the slate 	<ul style="list-style-type: none"> Computer ēno interactive whiteboard Projector 	<ul style="list-style-type: none"> The included stylus must be paired to the computer used with the existing ēno interactive whiteboard For room-to-room mobility, a complete ēno stylus kit is available
ēno 2125	<ul style="list-style-type: none"> Slate Stylus AAA battery PolyVision driver software Bluetooth radio dongle (2) spare stylus tips 	<ul style="list-style-type: none"> Use in a classroom as a stand-alone mobile teaching aid for teachers or students Use with or without an existing interactive whiteboard 	<ul style="list-style-type: none"> Computer Projector 	<ul style="list-style-type: none"> This is a complete kit allowing the slate to be used independently The ēno stylus must be paired to a computer with the included Bluetooth radio dongle and the PolyVision driver software
ēno 2130	<ul style="list-style-type: none"> Slate Stylus AAA battery PolyVision driver software Bluetooth radio dongle (2) spare stylus tips RM Easiteach software or Qwizdom WizTeach software 	<ul style="list-style-type: none"> Use in a classroom as a stand-alone mobile teaching aid for teachers or students Use with or without an existing interactive whiteboard Creating subject-specific lessons 	<ul style="list-style-type: none"> Computer Projector 	<ul style="list-style-type: none"> This is a complete kit that also includes comprehensive lesson creation software The ēno stylus must be paired to a computer with the included Bluetooth radio dongle and the PolyVision driver software

Dimensions

- HxW: 7.651" x 11.267"
(194.33mm x 286.18mm)
- Depth: 1.076" (27.34mm)
- Weight: 1.04 lbs (467 g)

Writing Surface

- e³ environmental ceramicsteel™ surface

Power Requirements

- No power requirements for the slate
- Stylus requires one AAA battery

Recommended Computer Requirements

- Microsoft Windows
- Pentium processor
 - 512MB RAM
 - XP, Tablet XP service pack 2 or above, or Vista®
 - One available USB port

Apple Macintosh

- PowerPC or Intel microprocessor
- 512MB RAM
- System software OS X 10.3.9 or higher
- One available USB port

Bluetooth Stack Support

ēno supports the following Bluetooth stacks:

- Windows: Microsoft, Toshiba, Blue Soleil™, Widcomm®/Broadcom®
- Macintosh: All Apple stacks

Environmental Certifications

- MBDC Cradle to Cradle Silver
- SCS Indoor Advantage Gold
- RoHS

Warranty

- Forever Warranty on the e³ environmental ceramicsteel surface, ten-year warranty on the slate, two-year warranty on the stylus and components.



eVision™ PolyVision is committed to move toward sustainability in all areas of environmental stewardship—to protect people, replenish natural resources, and restore the communities in which we work and live.

*Antimicrobial protection is limited to the treated article and does not protect a user against disease causing bacteria. Always clean products thoroughly after each use.

©2009 PolyVision Corporation. All rights reserved. Trademarks used herein are the property of PolyVision Corporation or of their respective owners. PolyVision Corporation reserves the right to make changes in product design, construction or detail, and to discontinue any product or material without notice.

PolyVision
a steelcase company

1.800.620.POLY
www.polyvision.com
info@polyvision.com

TECHENOMINI 0609