



ēno one®

height-adjustable mobile interactive classroom solution

Features

- **Flexibility**—Save valuable lesson time by controlling and interacting with ēno, the projector and peripherals in one place: at the board. Teachers are always ready to demonstrate key concepts from wherever the board is located.
- **Personalized learning on their level**—Students and teachers of any height comfortably interact with lesson content with a simple lift or push of the handle. Wheelchair accessibility enables special needs students go from struggling to participate in lessons, to working at the board with confidence.
- **More time for lessons**—Integration of ēno one's multi-user, multi-media and multi-functional features enable quick lesson reference and seamless instruction. A fun learning environment is guaranteed for all!
- **Uncomplicated training**—With just one solution to learn, teachers use dedicated buttons to manipulate the board and projector and seamlessly teach with the software they have always known and loved, maximizing valuable classroom time.
- **Maximized budgets**—Purchasing and support from one company, coupled with a simple installation, reduces time and costs for schools and districts seeking to get the most from their interactive technology implementation.
- **Cleaner and greener classrooms**—The ēno board is environmentally certified, recyclable and made with PolyVision's virtually indestructible *e³ environmental ceramicsteel™* surface. So, choosing the ēno one interactive classroom solution helps conserve natural resources and ensures clean air in the classroom—protecting our earth and children for generations.

One solution... absolute simplicity

The flexible and agile ēno one height-adjustable mobile solution is tailored for the comfort and safety of teachers and learners. Gliding the board up or down brings math problems to eye-level. The unobtrusive ultra-short throw projector minimizes shadows and glare. And, the dedicated projector icon strip gives the teacher more control—right at the board. No matter the teaching style or accessibility challenge, ēno one meets teachers and students wherever they are.

Touchboards

205 Westwood Ave, Long Branch, NJ 07740
 Phone: 866-94 BOARDS (26273) / (732)-222-1511
 Fax: (732)-222-7088 | E-mail: sales@touchboards.com

“We love ēno one's simple controls and that we can effortlessly roll it to other classrooms when needed.”

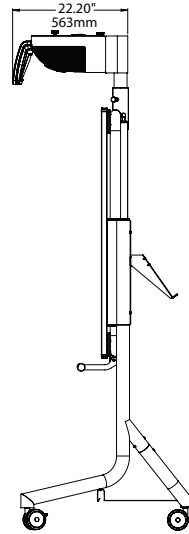
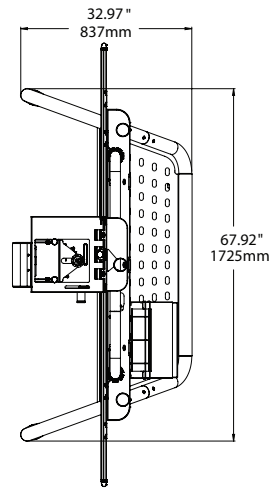
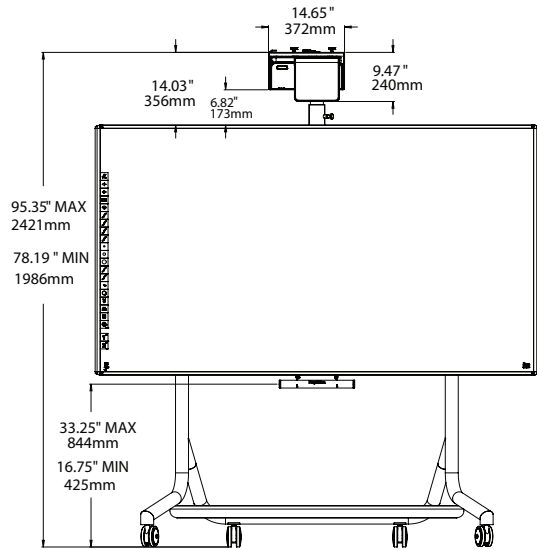

eño one height-adjustable mobile specifications

Interactive whiteboard

- Includes eño 2610 or eño 2810
- Environmentally certified: MBDC Cradle-to-CradleSM Silver and SCS Indoor Advantage Gold[®]
- Warranty: Forever Warranty[™] on the surface; 10 years on construction (including trim and mounting brackets); 2 years on stylus and Bluetooth[®] receiver
- Shipping specs for eño 2610: 71" x 54" x 5"; 69 lbs.
- Shipping specs for eño 2810: 91" x 54" x 5"; 94 lbs.

Height-adjustable mobile

- Height adjustment: 16.5" range of motion
- ADA compliant
- No pinch points: Height-adjustable mechanism is completely enclosed
- Internal cable storage
- Easy-lift handle made from 80,000 psi steel
- No-fail brake mechanism holds 2,000 lbs. of force
- Pivoting projector boom
- Storage shelf (included) holds up to 300 lbs. of distributed weight
- Laptop tray included
- 4" heavy-duty swivel casters (two locking)
- Finish: black and dark gray powdercoat
- Exceeds UL standard for tip test
- Warranty: 5 years

PolyVision PJ920 ultra-short throw projector

(PJ905 short throw projector is also available. See separate specifications.)

- DLP with Brilliant Color technology
- Native resolution: WXGA (1280 x 800)
- Aspect ratio: 16:10 Native, 4:3
- Brightness: 2500 Lumens (typical); 2200 Lumens (eco mode)
- Lamp life: 4000/6000 hrs.
- 6-segment color wheel (RGBCWY)
- Contrast ratio: 1500:1
- Throw Ratio: 0.192
- Keystone correction: ±15°
- 10 watt built-in speaker
- 3D-ready
- I/O connections: VGA (x2), HDMI, S-Video, Composite Video RCA, Audio mini jack (in and out loop), VGA Monitor Out
- Control terminals: LAN Ethernet RJ45, USB, Serial RS-232
- Networks: IP for remote management
- Compatibility for video system: NTSC/NTSC 4.43, PAL-B/G/H/I, SECAM
- Compatibility for video interface: Composite, S-Video, Component YPbPr, Component YCbCr, VESA Standard
- Format compatibility: QVGA, VGA, SVGA, XGA, SXGA+, UXGA
- Acoustic noise: 29dB (typical 230 W); 27 dB (typical eco mode 190 W)
- Weight: <20 lbs. (<9 kg)
- Lamp replacement accessible when mounted
- Warranty: 3 years on projector; 3 years on lamp
- Kensington theft protection
- Power cord: 4.5m
- VGA cable: 4.5m
- USB cable: 4.5m
- Power requirements: 100V-240V, 50 / 60 Hz
- Power consumption: 290 W (normal use); 240 W (eco mode); <1 W (standby)
- Temperature: 5°C ~ 40°C; -10°C ~ 60°C (non-operating)
- Operating altitude: sea level to 10,000' at 23°C
- Humidity: 10% - 85% (no condensation); 5% - 95% (no condensation, non-operating)

SKU	Interactive whiteboard	Projector	Mount
eño one 2610 MOB UST	eño 2610	PJ920	Height-adjustable carriage + Mobile Leg Kit
eño one 2810 MOB UST	eño 2810	PJ920	Height-adjustable carriage + Mobile Leg Kit



eVision[™] PolyVision is committed to move toward sustainability in all areas of environmental stewardship—to protect people, replenish natural resources, and restore the communities in which we work and live.

©2011 PolyVision Corporation. All rights reserved. Trademarks used herein are the property of PolyVision Corporation or of their respective owners. PolyVision Corporation reserves the right to make changes in product design, construction or detail, and to discontinue any product or material without notice.

102611



205 Westwood Ave, Long Branch, NJ 07740
 Phone: 866-94 BOARDS (26273) / (732)-222-1511
 Fax: (732)-222-7088 | E-mail: sales@touchboards.com

