

# Flue Gas Analyzer

## 712

Rev. 2.x Analyzers



**The Value Leader™**  
[www.tpi-thevalueleader.com](http://www.tpi-thevalueleader.com)

## Contents

1.	<b>Introduction</b>
2.	<b>General Overview</b>
3.	<b>Instrument Overview</b>
3.1	<b>Front View</b>
3.2	<b>Back View</b>
3.3	<b>Side Views</b>
3.4	<b>Top View</b>
4.	<b>Turning On &amp; Off and Charging</b>
4.1	<b>Turning On</b>
4.2	<b>Turning Off</b>
4.3	<b>Charging</b>
4.4	<b>Activating The Backlight</b>
5.	<b>Combustion Analysis</b>
5.1	<b>Overview</b>
5.2	<b>Procedure</b>
5.3	<b>Combustion Displays</b>
5.4	<b>Typical Test Locations</b>
5.5	<b>Typical Test Results</b>
6.	<b>Function Selection</b>
6.1	<b>Function 1 - Thermometer</b>
6.2	<b>Function 2 - Manometer</b>
6.3	<b>Function 3 - Combustible Gas Leak Detector</b>
6.4	<b>Function 4 - Date / Time</b>
6.5	<b>Function 5 - Combustion Analysis</b>
7.	<b>Saving Data</b>
8.	<b>Recalling Data</b>
9.	<b>Printing Data</b>
10.	<b>Logging Data</b>
11.	<b>Communicating to a PC</b>
<b>Appendix A</b>	<b>Specifications</b>
<b>Appendix B</b>	<b>Calibration &amp; Service</b>
<b>Appendix C</b>	<b>Guarantee</b>
<b>Appendix D</b>	<b>Installing the Optional A773 Filter</b>
<b>Appendix E</b>	<b>Error Codes and Trouble Shooting</b>
<b>Appendix F</b>	<b>CO Alarm &amp; Auto Power Off</b>
<b>Appendix G</b>	<b>Manually Initializing Sensors</b>

## 1. Introduction

Thank you for purchasing TPI brand products. The TPI 712 Flue Gas Analyzer is a state of the art, easy to use analyzer designed not only to display and calculate the required readings from a flue but also to cover most of the other measurements associated with combustion. The instrument is ruggedly constructed and comes with a 3 Year unit and 2 Year sensor Guarantee.

## 2. General Overview

The TPI 712 combustion analyzer uses state of the art electrochemical sensors. This sensor technology provides the longest lasting, most accurate and reliable means for performing combustion tests. The sensors in your analyzer will need to be replaced periodically and calibration is recommended once every year.

Electrochemical sensors by nature are always active. Therefore the time the analyzer is off and not being used must be taken into account when determining sensor life. The sensors in your analyzer are warranted for two years. This warranty does not cover sensors damaged through misuse of the analyzer.

You should keep the battery of your 712 charged so power is constantly being supplied to your sensors.

The following guidelines will help prevent damage to your sensors:

Always use the mini pump filter when testing flue gases.  
Always periodically check and replace the mini pump filter as needed.  
Always make sure the in-line filter / water trap is installed properly.  
Always periodically check and replace the in-line filter as needed.  
Always remove water or condensation from the inside of the in-line filter / water trap assembly prior to performing tests.  
Always use the optional oil filter (p/n A773) when performing tests on oil burning equipment.

## General Overview (Continued)

Never over saturate your sensors by performing tests on equipment with gas levels beyond the capability of your analyzer.

Always keep the A762 water trap / filter assembly clean and replace the filter as necessary. Replacement filter part number is A762F.

This manual will guide you through the functions of the TPI 712 which will give you many years of reliable service.

Your TPI 712 Flue Gas Analyzer comes complete with the following standard accessories:

- TPI 712 Instrument
- Rubber Boot (A765)
- Infrared Printer (A740) (model 712A740 comes with the printer)
- Soft Carrying Case (A768)
- Flue Sampling Probe (A770)
- In-Line Filter installed on Flue probe (A762)
- Spare In-Line Filter (one included) (A762F is a package of 5 filters)
- Temperature Probe (GK11M)
- Battery Charger (A766)
- Mini Pump Protection Filter Assembly and spare filters (A763)
- Exhaust Spigot (removable) (A764)
- Pressure Tubing (A774)
- Static Pressure Tips (A776)x2
- Barbed to 1/8" NPT fittings (2 each)
- Gas Valve Adapter (A611)
- Adapter Tubing ( )
- Instruction Manual

( ) Denotes part number

Your TPI 712 Flue Gas Analyzer has the following options available:

- PC Software for analysis of Data Logging results (see 11 & Appendix B)
- Infrared PC link for non compatible PCs (see 11 & Appendix B)
- Various Temperature Probes (see Appendix B)

## 3. Instrument Overview

### 3.1 Front View



<b>Rubber Boot</b>	Protects the instrument from accidental damage
<b>Display</b>	Large 3 Parameter Backlit LCD Display
<b>Battery Condition Icon</b>	Shows condition of rechargeable batteries.
<b>Keypad</b>	Selects all available functions
<b>Selected Fuel Type</b>	N GAS, LPG, LIGHT OIL, HEAVY OIL, OPT 1 (Bituminous Coal), OPT 2 (Anthracite Coal), OPT 3 (Coke), OPT 4 (Butane), OPT 5 (Wood), OPT 6 (Bagasse)



Scrolls through selectable fuels (see 3.1 & 4.1)  
 Switches between Gross and Net Efficiency (see 5.3)  
 Switches between °C and °F (see 5.3 & 6.1)  
 Scrolls through mbar, kPa and inH2O (see 6.2)  
 Moves up through the Stored Data Addresses (see 7, 8, 9)  
 Increases data logging time intervals (see 10)



Zeroes pressure reading (see 6.2)  
 Moves down through the Stored Data Addresses (see 7, 8, 9)  
 Decreases data logging time intervals (see 10)



Scrolls through Combustion Analysis Displays (See 5.3)  
 Scrolls through Function Screens (see 6)  
 Turns temperature differential calculation ON/OFF (see 6.1)  
 Turns ch2 temperature ON/OFF (see 6.2)  
 Allows you to change the Date and Time (see 6.4)  
 Allows you to choose a Stored Data Address (see 7, 8, 9, 10)



Sends stored data to a separate infrared printer (see 9)  
 or IRDA adapter (p/n A767) (See 11)



Allows you to view stored data on the display (see 8)



Stores readings to memory (see 7)  
 Starts and Stops data logging (see 10)



Scrolls through and selects analyzer functions (see 6)  
 Turns Backlight ON and OFF (see 4.4)



Turns the instrument ON and OFF (see 4.1 & 4.2)

### 3.2 Back View

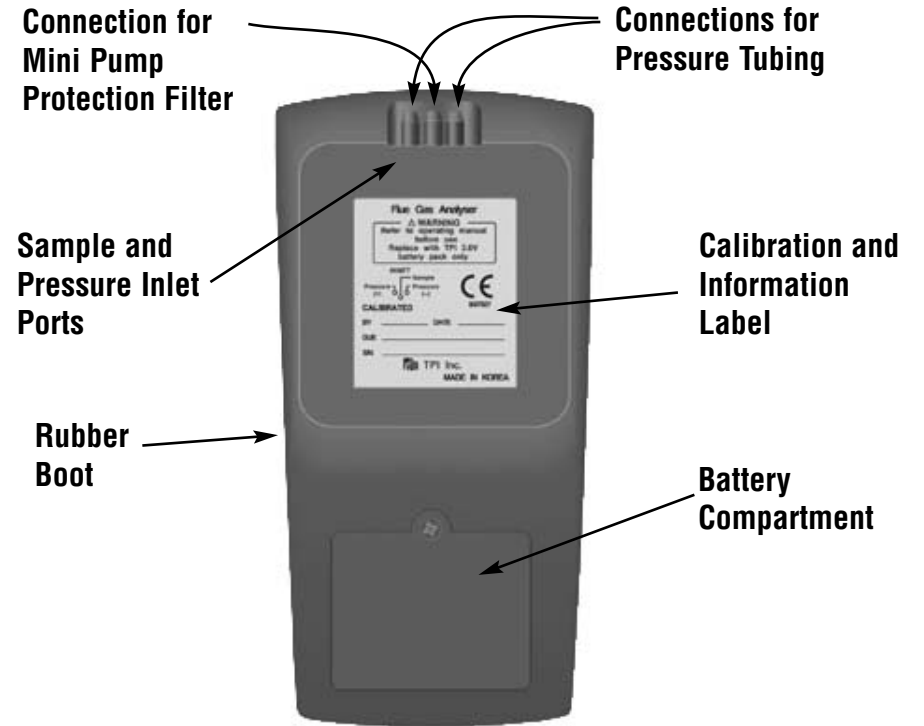

**Sample and Pressure Inlet Ports:** Connection for Gas Sampling Probe (see 3.4 & 5.2)

**Connection for Mini Pump Protection Filter** (see 3.4 & 6.2)

**Connections for Pressure Tubing:** (see 3.4 & 6.2)

**Calibration and Information Label:** Displays calibration information and Displays serial number

**Battery Compartment:** Holds rechargeable battery

**Rubber Boot** Protects the instrument

### 3.3 Side Views

**Exhaust Port**

Port for connection of Exhaust Adapter

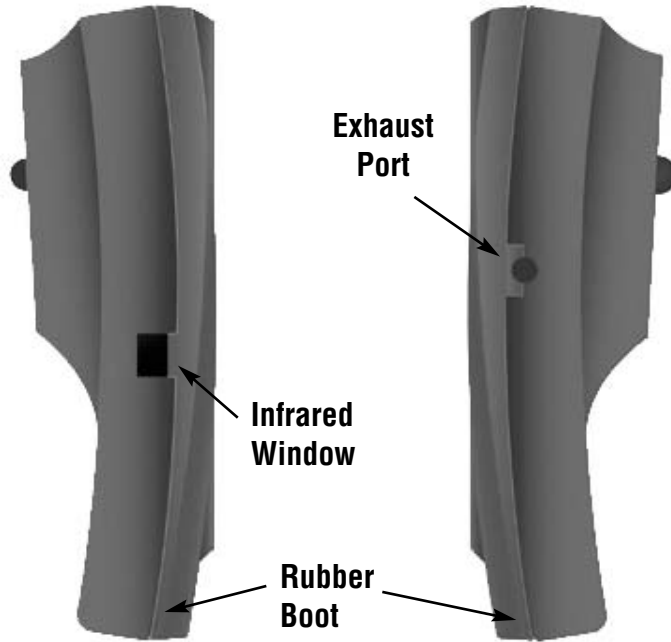

**Infrared Window**

Window for sending stored data to IR Printer or PC (see 9 & 11)

**Rubber Boot**

Protects the instrument from accidental damage

### 3.4 Top View

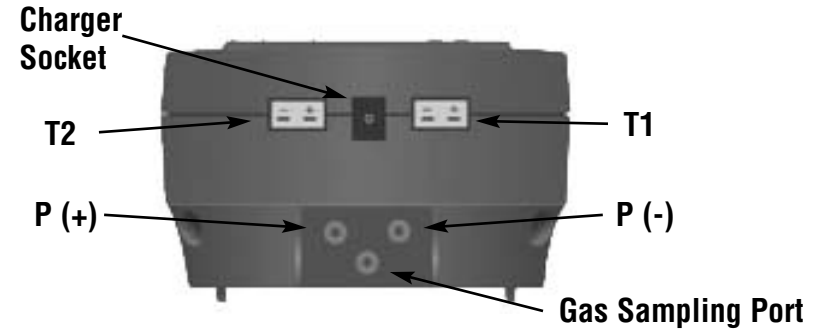

**Charger Socket**

Connection for 220V/115V charger (see 4.3)

**T1 Socket**

Connection for thermocouple plug on flue probe (see 5.2)

Connection for any 'K' type thermocouple probe (see 6.1)

**T2 Socket**

Connection for any 'K' type thermocouple probe (see 5.2 & 6.1)

**Gas Sample Port**

Connection for Gas Sampling Probe (see 5.2)

**P (+) Port**

Connections for Pressure Tubing (see 6.2)

**P (-) Port**

Connections for Pressure Tubing (see 6.2)

## 4. Turning On & Off and Charging

### 4.1 Turning On

**Always:** - Before turning on please ensure that the Mini Pump Protection Filter assembly and the Temperature Sampling Probe complete with In-Line Filter or the Tubing & In-Line Filter for Leak Detection are **not** connected to the Gas Sample Port (see 2.2 or 2.4)

Press and hold down the Power Key and the TPI 712 will start its 30 second countdown 'PURGE' will be displayed: - The instrument **MUST** be turned on in a clean air environment as the 30 second purge will set the Carbon Monoxide level to Zero and the Oxygen to 20.9%.

Ensure that the filters are clean and dry as dirty or wet filters will result in a loss of flow rate and 'Lo Flo' will be displayed to inform you that filters should be changed

During the last 20 seconds of the 30 second purge time the user can scroll through the following Fuels: - Natural Gas, LPG, Light Oil, Heavy Oil, OPT1 : Bituminous Coal, OPT 2 : Anthracite Coal, OPT 3: Coke, OPT 4: Butane, OPT 5: Wood (Dry), OPT 6: Bagasse by pressing the Up Arrow Key to select the Fuel they are working with. When desired fuel is displayed release the key, displayed fuel is now selected.

After the 30 second countdown the instrument is ready to take Flue, Temperature, Pressure or Leak Detection readings and Combustion Display 1 will be the first display.

The 712 will auto power off if no keys have been pressed for 10 minutes and the CO level is below 15ppm.

The Scroll/Enter Key allows you to scroll through the combustion displays as outlined in section 5.3. The Func Key is used to select the 712 function mode and allows you to set it to be a combustion analyzer, manometer, thermometer, or combustible leak detector. In addition, the Func Key is used to access the date and time display. See section 6 for more information on the Func Key.

**NOTE:** *When selecting oil as fuel be sure to use the optional oil filter (A773) or readings could become erratic. See Appendix E for installation instructions.*

### 4.2 Turning Off

Always: - Before turning off return the instrument to a clean air environment and allow the Carbon Monoxide level to return to below 15ppm and the Oxygen level to return to 20.9% ( $\pm 0.3\%$ ) Press the Power Key to turn the instrument off:- NOTE Should you attempt to turn the instrument Off and the CO reading is above 15ppm then the instrument will remain On and a short Beep will be heard. The Instrument can only be switched off if the CO is below 15ppm

The instrument has an auto shut off after 10 minutes should no keys have been pressed for this period and as mentioned above that the CO is below 15ppm. Should the CO be above 15ppm then the 10 minute auto shut off countdown will not begin till the CO has gone below 15ppm

### 4.3 Charging

Plug the Charger supplied into the charger socket on the instrument (see 3.4). If the instrument is turned on then a charging symbol will be displayed. Should the instrument then be turned off, turn off automatically or be turned off when the charger is plugged in then the charging symbol will not be displayed BUT the instrument will still be charging.

The instrument should be charged overnight for a period of 10 to 12 hours and will give over 6 hours Operating Time. If a beeping noise is heard during charging disconnect the charger. This is an indication of something wrong in the charging circuit. Please contact TPI technical assistance at 800-368-5719.

Alternatively, the instrument can be used when plugged into the charger.

### 4.4 Activating the Backlight

The display backlight can be activated at any time by pressing and holding down the Func Key for approximately 2 seconds. The backlight will automatically shut off after approximately 20 seconds to preserve battery life.

## 5. COMBUSTION ANALYSIS

### 5.1 Overview

Testing for carbon monoxide, oxygen, and stack temperature is very important to the overall safety and efficiency of heating equipment. The following guidelines and descriptions are generic and meant to provide you with a basic understanding of combustion testing. TPI always recommends you contact the manufacturer of the device under test, obtain information specific to the device, and follow the procedures and safety guidelines for performing tests and affecting repairs.

In general, for most applications flue gas samples should be taken prior to the draft diverter or any other opening that allows room air to enter the system. This prevents room air from mixing with gases in the flue and diluting the test sample. To ensure accurate and consistent combustion tests, it is important gas and temperature samples be taken at the same location. This is easy with the TPI flue probe because the temperature sensor is an integral part of the probe.

Prior to taking a sample, the device under test should be on and operating. Putting the flue probe in the sample area prior to starting the device may cause saturation of the sensors due to the higher initial concentration of carbon monoxide that may be encountered upon start up. If this happens, allow your analyzer to purge in fresh air until the carbon monoxide level returns to 0 ppm and the oxygen level returns to 20.9%. This may take more than an hour depending on how saturated the sensors are.

The included figures show locations for performing tests on commonly encountered equipment. Remember to consult with the manufacturer of the device under test for specific test information.

**NOTE:** *When selecting oil as fuel be sure to use the optional oil filter (A773) or readings could become erratic. See Appendix E for installation instructions.*

## COMBUSTION ANALYSIS (Continued)

### 5.2 Procedure

1. Turn the 712 on as outlined in section 4.1. At any time you can activate the Backlight by holding down the Func/Backlight Key for 2 seconds. The backlight will automatically shut off after 20 seconds to preserve battery life.

2. Ensure you have connected the Mini Pump Protection Filter assembly and Temperature Sampling Probe complete with In-Line Filter to the Gas Sample Port (see 3.2 or 3.4) and the 'K' Type Thermocouple Plug into Thermocouple (T1) Socket (see 3.4). The GK11M ambient air temperature probe must be connected to the (T2) socket. (refer to figure below for correct hookup)

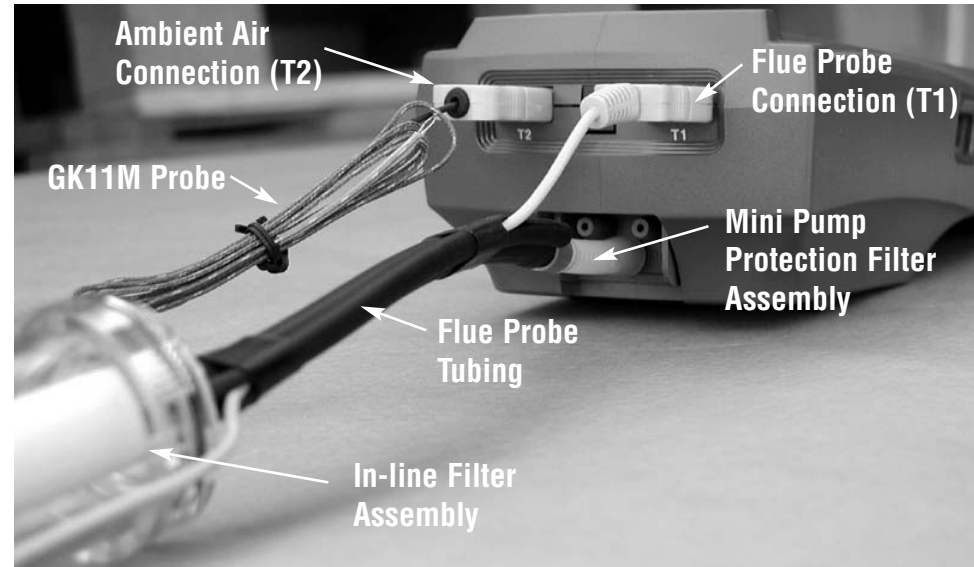

**WARNING:** - Ensure that the In-Line Filter hangs in a vertical position when readings are being taken, particularly if water is visible. Failure to comply may result in damage to the instrument.

**WARNING:** - There is ONLY one correct way to connect the 'K' type thermocouple plug into the socket (see 2.4). Forcing the plug into the socket the wrong way round may result in damage to the instrument.

3. Insert the flue probe into the test location of the device under test. The probe tip should be in the middle of the flue pipe or exhaust stream. Refer to figures 1 through 3 for typical test locations.

## COMBUSTION ANALYSIS (Continued)

4. As seen below, use the Scroll/Enter Key to move through the various combustion displays.

### 5.3 Combustion Displays

You can move through the following Combustion Analysis Screens by repeatedly pressing Scroll/Enter:



- **Combustion Display 1 (Default Start Up Display)**
- Displays Carbon Monoxide (CO) reading in parts per million (ppm)
- Displays calculated Carbon Dioxide (CO<sub>2</sub>) figure in percentage (%)
- Displays calculated CO/CO<sub>2</sub> (Ratio) figure

**WARNING:** - Should the CO reading rise above 2,000ppm a continuous series of Alarm Beeps will be heard. The Probe should immediately be disconnected from the instrument and the instrument returned to a clean air environment. This Alarm alerts the user that there is a high concentration of CO, and this procedure will protect the sensors within the instrument.



- **Combustion Display 2**
- Displays Oxygen (O<sub>2</sub>) reading in percentage (%)
- Displays calculated Excess Air (X Air) figure in percentage
- Displays calculated Efficiency (Eff.) figure in percentage
- Pressing the Up Arrow Key will toggle between Gross & Net Efficiency (**Note: Gross Efficiency is used in the USA**)



- **Combustion Display 3**
- Displays Carbon Monoxide (CO) reading in parts per million (ppm)
- Displays Oxygen (O<sub>2</sub>) reading in percentage (%)

## COMBUSTION ANALYSIS (Continued)

### 5.3 Combustion Displays (continued)



- **Combustion Display 4**
- Displays CO air free (-CF-)



- **Combustion Display 5**
- Displays Temperature reading of Channel 1 (T1)
- Displays Temperature reading of Channel 2 (T2)
- Displays the Differential Temperature (Diff.) between ch1 and ch2
- 'oPEn' will be displayed if no 'K' type probe is connected to the thermocouple socket
- Press the Up Arrow Key to switch between °C and °F

5.. During a combustion test you can save, print, and send data to a computer. See section 7 through 11. Allow readings to stabilize before saving or printing the data.

6. After the test is complete, remove the flue probe from the test location and allow the analyzer to purge in a fresh air environment. Turn the analyzer off as outlined in section 4.2.

**NOTE:** When selecting oil as fuel be sure to use the optional oil filter (A773) or readings could become erratic.



## 5.4 TYPICAL TEST LOCATIONS

### Atmospheric Gas Fired Fan Assist Boiler / Furnace

#### Typical Test Locations

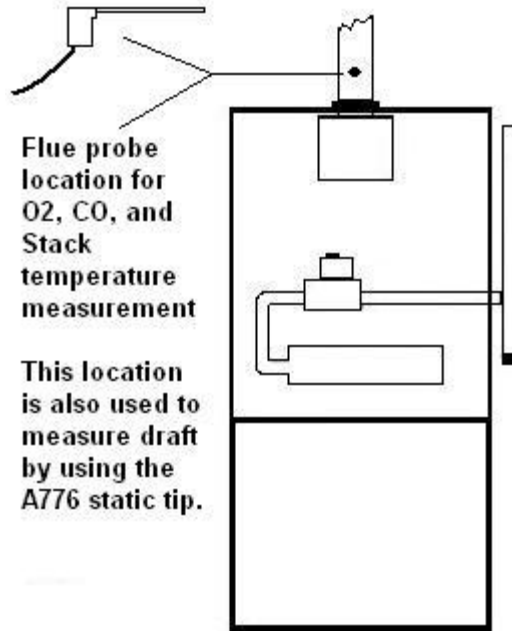

Figure 1

### Condensing Boiler / Furnace

#### Typical Test Locations

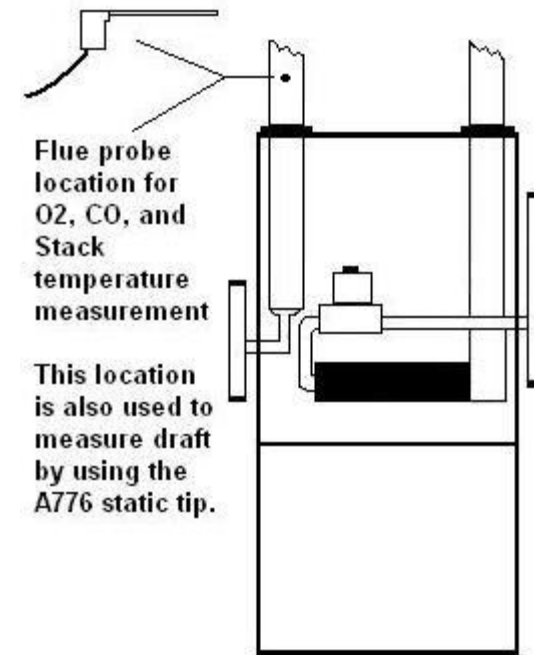

Figure 2

## COMBUSTION ANALYSIS (Continued)

### Atmospheric Forced Air Furnace

#### Typical Test Locations

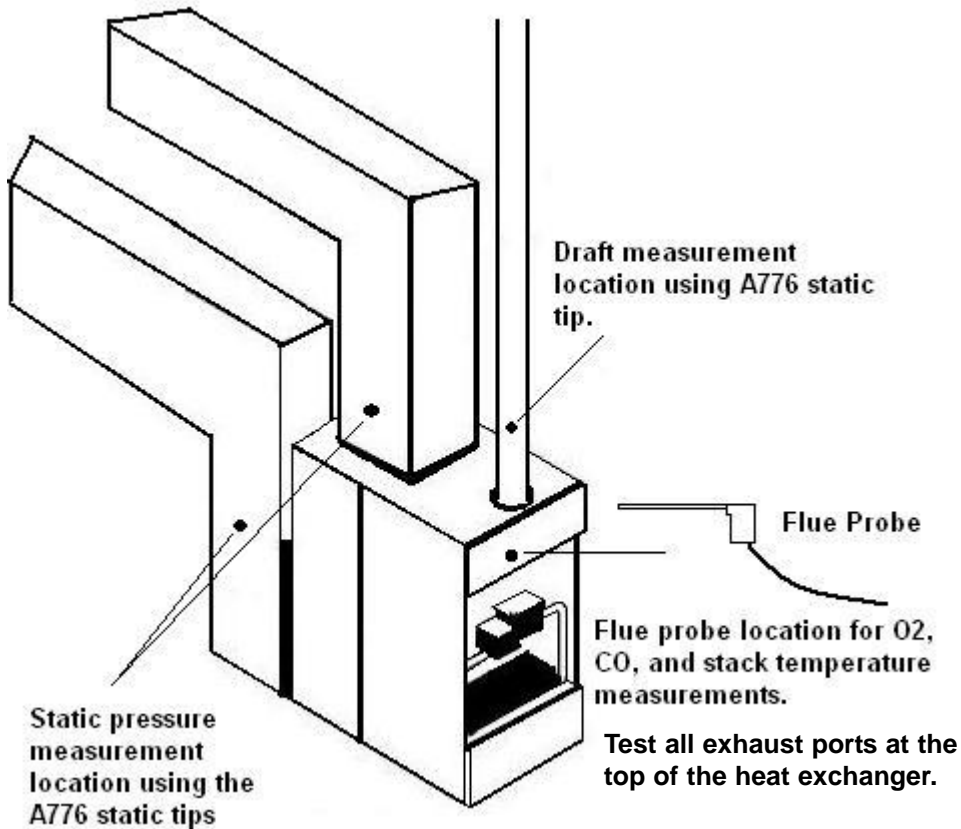

Figure 3

## COMBUSTION ANALYSIS (Continued)

### 5.5 TYPICAL TEST RESULTS

*Actual test results vary depending on the equipment under test. TPI recommends you check with the manufacturer of the equipment being tested to determine specific acceptable results.*

#### Power Burners (Gas Fired)

<b>Oxygen</b>	3% to 6%
<b>Carbon Monoxide</b>	Less than 100ppm (air free)
<b>Stack Temperature</b>	300°F to 500°F
<b>Draft</b>	-0.15 inH <sub>2</sub> O

#### Power Burners (Oil Fired)

<b>Oxygen</b>	4% to 7%
<b>Carbon Monoxide</b>	Less than 100ppm (air free)
<b>Stack Temperature</b>	325°F to 625°F
<b>Draft</b>	-0.15 inH <sub>2</sub> O

#### Gas Fired Burners (Atmospheric / Fan Assist)

<b>Oxygen</b>	7% to 9%
<b>Carbon Monoxide</b>	Less than 100ppm (air free)
<b>Stack Temperature</b>	325°F to 500°F
<b>Draft</b>	-0.15 inH <sub>2</sub> O to -0.4 inH <sub>2</sub> O

## 6. FUNCTION SELECTION

Pressing the Func Key enables access to the different functions available on the 712. Available functions are: Combustion Analyzer, Thermometer, Manometer, and Date / Time display.

### 6.1 Function 1: - Thermometer

Press the Func Key repeatedly to access the thermometer function. In this mode the 712 functions like a K-Type thermocouple thermometer. The pump will stop running when in this function.

The thermometer function allows you to perform temperature tests.



#### Function Display 1 (Temperature)

T1 Temperature  
T2 Temperature  
Differential Temperature

1. Ensure you have a 'K' type probe connected to one or both of the thermocouple sockets T1 or T2 (refer to figure below)

**WARNING:** - There is ONLY one correct way to connect the 'K' type thermocouple plug into the socket (see 4.2). Forcing the plug into the socket the wrong way may result in damage to the instrument.

2. Touch the temperature probe to the item under test and read the displayed



temperature.

Other Features:

- Pressing the Up Arrow Key will toggle between °C and °F
- Pressing the Scroll/Enter Key will toggle the Differential Temperature ON and OFF
- 'oPEN' will be displayed if no 'K' type probe is connected to the thermocouple socket

### 6.2 Function 2: - Manometer

Press the Func Key repeatedly to access the thermometer function. In this mode the 712 functions like a differential manometer. The pump will stop running when in this function.

1. Ensure you have

The pressure function allows you to perform draft and pressure tests.

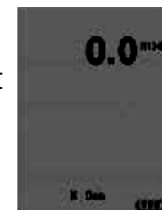

#### Function Display 2 (Pressure)

Pressure Reading  
T2 Temperature

Pressure Sampling Tube connected to one or both of the Pressure Ports and there are no restriction in the tubing (see figure below)



2. Zero the display by pressing the Down Arrow Key.
3. Connect the tube(s) to the device under test and read the pressure on the display.

Other Features:

- Pressing the Up Arrow Key will scroll through mbar, kPa and inH2O
- Pressing the Down Arrow Key will Zero the Pressure reading
- Pressing the Scroll/Enter Key will toggle the ch2 temperature reading ON and OFF

The 712 incorporates a differential manometer. This means when a single hose is connected to the (+) port and pressure is applied, the 712 will read positive pressure. If a single hose is connected to the (-) port and pressure is applied, the 712 will read a negative pressure. If both ports are connected to a pressure, the 712 will read the difference (P1 - P2) between the two.

### 6.3 Function 3: - Combustible Gas Leak Detection

Press the Func Key repeatedly until the 25 second countdown screen is reached. The 712 will countdown from 25 then '0 Leak' will be displayed. In this mode the 712 functions like a combustible gas leak detector.

The Leak function allows you to perform combustible gas leak tests.



**Function Display 3 (Leak Detection)**  
Combustible gas leak detection expressed as a level from 0 to 3. See below.

1. Ensure you have the Tubing & In-Line Filter for Leak Detection connected to the Gas Sample Port (see figure below)



PLEASE ENSURE THAT THE MINI PUMP PROTECTION FILTER ASSEMBLY IS IN PLACE AT ALL TIMES IN THIS FUNCTION

2. Locate combustible gas leaks by putting the inlet of the 712 near fittings and valves. Leaks will show as a level between 0 and 3 and an audible beep will be heard.

Level of Flammable Gas detected as follows: -

Value on Screen

0 < 100ppm  
1 > 100ppm but < 1,000ppm  
2 > 1,000ppm but < 10,000ppm  
3 > 10,000ppm

Tone Sounded

No Tone  
Long Pitched Tone  
Medium Pitched Tone  
Short Pitched Tone

### 6.4 Function 4: - Date/Time

Press the Func Key repeatedly to access the date/time screen. From this function Time, Date and Year can be changed.



**Function Display 4 (Date / Time)**

Time  
Date / Month  
Year

1. Once the Time, Date, and Year screen is displayed, press the Scroll/Enter Key once to allow you to change the data.
2. Press the Up Arrow Key to Increase the Minutes
3. Press the Down Arrow Key to Decrease the Minutes
4. Press the Scroll/Enter Key to confirm the desired Minute and move onto the Hours
5. Repeat steps 2 to 4 to change the Hour, the Day, the Month and the Year
6. The unit will return to normal after the desired Year has been confirmed

### 6.5 Function 5: - Combustion Analysis

Press the Func Key repeatedly to return to Combustion Analysis mode and the default display (Combustion display 1)



- **Combustion Display 1 (Default Start Up Display)**
- Displays Carbon Monoxide (CO) reading in parts per million (ppm)
- Displays calculated Carbon Dioxide (CO2) figure in percentage (%)
- Displays calculated CO/CO2 (Ratio) figure

## 7. SAVING DATA

During testing, data can be stored for later retrieval by following these steps:

1. Press the Store/Logger Key once  
'Addr' will be displayed on the top line along with 'SA ' and a location number from 0 to 9 will be flashing on the screen. Select the required address location that you wish to save the data to by pressing the Up and Down Arrow Keys
2. Press the Scroll/Enter Key once  
The location number which you have chosen will stop flashing and after about 3 seconds the instrument will return to the screen/function you were previously on.

You have just successfully stored a set of readings which can be either reviewed on screen (see 6) or sent to the IR printer (see 9)

When data is saved, all data previously in the address will be overwritten. When saving pressure/draft readings, select an address different from the one used to save combustion readings.

## 8. RECALLING DATA

1. Press the Recall Key once  
'Addr' will be displayed on the top line along with 'SA ' and a location number from 0 to 9 will be flashing on the screen. Select the required address location that you wish to save the data to by pressing the Up and Down Arrow Keys
2. Press the Scroll/Enter Key once  
The Time & Date of the Saved Data from the selected address location will be displayed flashing on the screen.  
The rest of the Saved Data at this address location can be reviewed by pressing the Up and Down Arrow Keys
4. Press the Scroll/Enter Key once when you are finished reviewing the data.  
'End' will be displayed with 'YES' flashing
5. Press the Scroll/Enter Key once to EXIT  
or
6. Press the Up or Down Arrow Keys  
'End' will be displayed with 'no' flashing
7. Press the Scroll/Enter Key once to CHOOSE another address location to review and repeat steps 2 to 5

## 9. PRINTING DATA

**WARNING:** - To operate correctly there must be a clear line of sight between the Infrared Window on the instrument (see 3.3) and the Infrared Window on the IR Printer (see Printer instructions). Place the printer so it is no closer than approximately 6 inches from the analyzer.

1. Press the Print/COM Key once  
'rEAL' and "Stor" will be displayed and 'rEAL' will be flashing.  
Selecting 'rEAL' will cause the 712 to print the test data currently on the display (real time data). Selecting 'Stor' will cause the 712 to print data stored in memory. Use the Up and Down Arrow Keys to select the desired print mode and press the Scroll/Enter Key.

**REAL Print Mode** - If rEAL print mode is selected, the analyzer will display 'Wait' 'out' and bars will change position on the LCD until printing is complete.

After printing is complete, 'End' will be displayed and 'YES' (or 'no') will blink. Selecting 'YES' will return the 712 to normal operation, selecting 'no' will return the 712 to the print selection screen so you can print again. Use the Up and Down Arrow Keys to make the selection and press the Scroll/Enter Key.

**STOR Print Mode** - If Stor mode is selected, 'Addr' will be displayed on the top line along with 'SA ' and a location number from 0 to 9 will be flashing on the screen. Select the required address location that you wish to print data from by pressing the Up and Down Arrow Keys and press the 'Scroll/Enter' Key. The analyzer will display 'Wait', 'out' and bars will change position on the LCD until printing is complete.

After printing is complete, 'End' will be displayed and 'YES' (or 'no') will blink. Selecting 'YES' will return the 712 to normal operation, selecting 'no' will return the 712 to the print selection screen so you can print again. Use the Up and Down Arrow Keys to make the selection and press the Scroll/Enter Key.

**Combustion and pressure/draft printouts must be performed separately. Perform a combustion test and save the data. Perform a pressure/draft test and save the data in a different address. Print each address separately.**

## 10. LOGGING DATA

1. Press and hold down the Store/Logger Key for approximately 2 seconds  
'S-t' will be displayed with '05 S' flashing indicating that the instrument will log a set of 100 readings every 5 seconds.  
You can choose from the following logging times  
'05 S' (100 readings total, 1 reading recorded every 5 seconds)  
'10 S' (100 readings total, 1 reading recorded every 10 seconds)  
'20 S' (100 readings total, 1 reading recorded every 20 seconds)  
'30 S' (100 readings total, 1 reading recorded every 30 seconds)  
'01 M' (100 readings total, 1 reading recorded every 1 minute)  
'03 M' (100 readings total, 1 reading recorded every 3 minutes)  
by pressing either the Up or Down Arrow Keys
2. Press the Scroll/Enter Key once  
'PAGE PA ' will be displayed and a page number from 0 to 3 will be flashing.  
Select the required page location that you wish to log the saved data to by pressing the Up and Down Arrow Keys
3. Press the Scroll/Enter Key once  
The instrument will return to the previous screen/function with 'Logger' flashing on the top line.  
The instrument will continue logging until all 100 readings have been saved or you press and hold down the Store/Logger Key.  
**WARNING:** - The instrument will not Turn Off if data logging is commencing. A beep will be heard to warn you of this fact if you try to turn the instrument off.

**Logged data can only be retrieved by sending the information to a computer. This requires the use of the optional A767 IRDA adapter and either Microsoft Hyper Terminal or the optional PC software part number A772.**

## 11. COMMUNICATING TO A PC

This function requires the optional A767 IrDA Adapter. Please refer to the A767 manual for complete instructions on using the adapter. Optional software part number A772 is available for use with MICROSOFT® WINDOWS or communication can be performed using MICROSOFT® HYPER TERMINAL.

### USING MICROSOFT® HYPER TERMINAL

1. Open MICROSOFT® HYPER TERMINAL and set the COM port as follows:
  - Baud: 9600
  - Data Bits: 8
  - Parity: None
  - Stop Bit: 1
  - Flow Control: None
2. Press and hold the Print/Com Key until a beep is heard and 'COMM' is flashing in the upper right hand of the display.
3. Connect the A767 to the computer and turn it on. Place the A767 6 to 8 inches from the 712 with a clear line of sight between the sensor windows.
4. Press and hold the Recall key until a beep is heard. The 712 will display 'Real', 'Stor', and 'Logg'. Using the Up and Down Arrow Keys, select the desired transfer mode and press the Scroll/Enter Key.

**Real** : This mode will transfer current readings (real-time) to the computer. After communication the 712 will return to normal operation.

**Stor**: This mode will transfer the 10 save locations to the computer. While the 712 is communicating 'Stor Out' will be displayed. After communication is complete the 712 will return to normal operation.

**Logg**: This mode will transfer logged data locations 0 through 99 of the selected page (0 through 3). When the 712 is communicating 'Logg Out' will be displayed. After communication is complete the 712 will return to normal operation.

## COMMUNICATING TO A PC (Continued)

5. To return to normal operation press and hold the Print/Comm Key until a beep is heard and 'COMM' is no longer displayed.

Requests for stored and real data can be made from the PC through Hyper Terminal to the 712.

### Requesting Sored Data

1. Follow steps 1 through 3.
2. From your computer type QTS (All Caps) and press ENTER.
3. The 712 will send stored data and return to normal operation.

### Requesting Real Data

1. Follow steps 1 through 3.
2. From your computer type QTR (All Caps) and press ENTER.
3. The 712 will send Real time data and return to normal operation.

If using the optional PC software part number A772, please refer to the instructions that comes with the software.

## Appendix A : SPECIFICATIONS

### Instrument

Operating Temperature Range	14°F to +122°F (-10°C to +50°C)
Battery	Rechargeable Ni-MH
Battery Life	> 6 Hours
Charger Input Voltage	115V or 230V : 50/60 Hz AC
Fuels	Natural Gas, LPG, Light Oil, Heavy Oil
Pressure Ranges	mbar, kPa & inH2O
Display	Backlit LCD
Data Storage	10 sets of readings
Data Logging	400 sets of readings on 'Timed Interval Logging'
Time & Date	24 Hour Real Time Clock
Dimensions	200mm x 90mm x 60mm
Weight	500g
Casing	Rubber Boot as Standard
Switch Off	Failsafe
Exhaust	Safety Spigot
Conforms to	BS7927 (and the draft BS7967)

## Appendix A : SPECIFICATIONS (Continued)

### Flue Temperature Probe

Construction	Pistol Grip with Stainless Steel Shaft
Hose Length	2500mm
Insertion Length	200mm
'K' Type Thermocouple Accuracy	+/- 0.3%, +/- 1°C
Maximum Temperature	800°C

### Gases

	Range	Resolution	Accuracy
Oxygen	0-25%	0.1%	+/- 0.3%
Carbon Monoxide	0-10,000 ppm	1 ppm	+/- 5 ppm or 5% Whichever is greater
Carbon Dioxide	0-25%	0.1%	Calculated
CO/CO2 Ratio	0-0.999	0.001	Calculated
Combustion Efficiency	0-100%	0.1%	Calculated
Gas Leak Sensor	20-10,000 ppm		

### Pressure Measurement

Selectable Ranges	mbar, kPa and inH <sub>2</sub> O
Range	- 150 mbar to + 150 mbar -15 kPa to + 15 kPa -60 inH <sub>2</sub> O to 60 inH <sub>2</sub> O
Resolution	0.01 mbar
Accuracy	+/- 0.5% fsd

## Appendix B: CALIBRATION & SERVICE

It is recommended that the instrument be calibrated every 12 months. Please consult Test Products International for further details.

The following are consumable parts for the instrument:

In-Line Filter Element (pkg of 5)	User Replaceable	A762F
Mini Pump Protection Filter Assem.	User Replaceable	A763
**Oxygen Sensor	User / Factory Replaceable	A761
**Carbon Monoxide Sensor	User / Factory Replaceable	A760
<i>**Sensor replacement requires calibration gas.</i>		

The following are accessories for the instrument:

Flue Temperature Probe w/k-type	Standard	A770
'K' Type Temperature Probe	Standard	GK11M
In-Line Filter Complete	Standard	A762
Mini Pump Protection Filter Assem.	Standard	A763
Battery Charger	Standard	A766
Rubber Boot	Standard	A765
Infrared Printer	Optional	A740
Soft Carrying Case	Standard	A768
Exhaust Spigot	Standard	A764
PC Software	Optional	A769
IRDA-RS232C Adapter	Optional	A767

## Appendix C: GUARANTEE

Your TPI 712 Flue Gas Analyzer is guaranteed free from defects in materials and workmanship for 3 Years from the date of purchase. This guarantee does not affect your statutory rights. For additional information please refer to the included warranty card or contact TPI at 800-368-5719.

To obtain warranty performance or maintenance on your analyzer: - Include with the product your name, address, phone number, written description of the problem and proof of purchase date. Carefully package and return to:

TPI / Attn. Repair  
9615 SW Allen Blvd. Suite 104  
Beaverton, OR 97005



## Appendix D: INSTALLING THE OPTIONAL A773 OIL FILTER

When performing combustion tests on oil fired equipment it is important to use the optional A773 oil filter to ensure stable readings. The A773 does not have to be removed when working with other types of fuels.

### PROCEDURE

1. Pull the yellow thermocouple out of the cord channel in the tubing up to the cord stop.
2. Cut the tubing approximately 1 1/2 inches from the end of the A762 water trap / filter assembly.

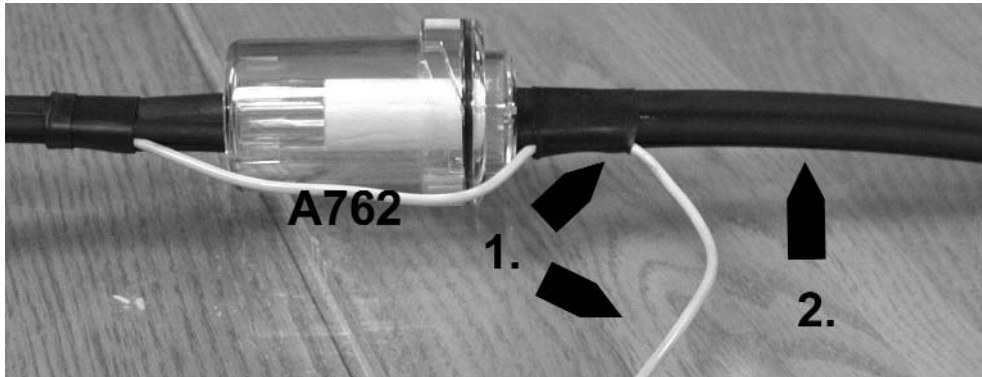

3. Insert the A773 oil filter into the tube below the A762.
4. Cut the remaining piece of tube into a 1 1/2 inch piece and connect it onto the end of the A773 oil filter.
- 5.. Press the thermocouple cord into the cord channel.

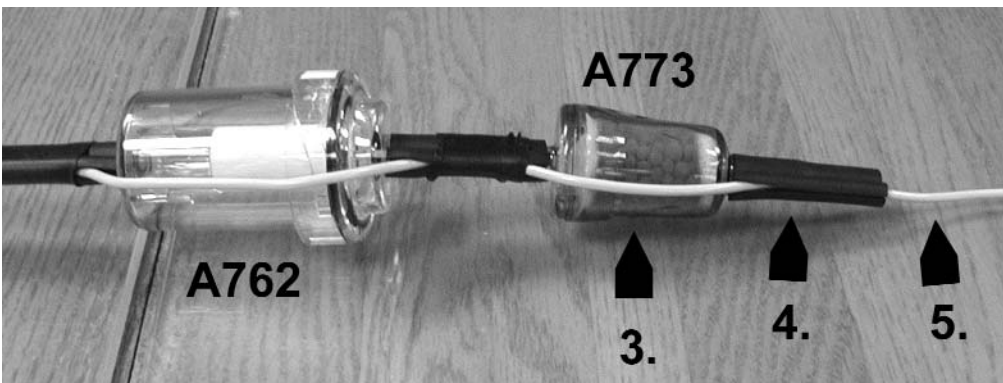

The A773 should be replaced when most of the pellets become discolored.

## Appendix E: ERROR CODES & TROUBLESHOOTING

The 712 analyzer will display certain codes to let you know of a malfunction.

Code Displayed	Code Definition	Possible Causes	Corrective Action
<b>Flo Err</b>	Pump not drawing sample at correct flow rate.	Blockage / kink in flue probe hose.  Dirty or blocked filter(s).  Worn pump.	Check and rectify.  Replace filter(s).  Return to TPI for service.
<b>Intl O2 Err</b>	Oxygen sensor failed to initialize	Flue probe connected to 712 prior to power up.  712 did not purge completely from last sample.  Worn or defective oxygen sensor.	Disconnect probe and restart.  Purge for 20 minutes and restart.  Return to TPI for sensor replacement or install new sensor.*  Try manually initializing the sensor. See Appendix G.
<b>Intl CO Err</b>	Carbon monoxide sensor failed to initialize.	Flue probe connected to 712 prior to power up.  712 did not purge completely from last sample.  Worn or defective carbon monoxide sensor.	Disconnect probe and restart.  Purge for 20 minutes and restart.  Return to TPI for sensor replacement or install new sensor.*  Try manually initializing the sensor. See Appendix G.
<b>Lo bat</b>	Low battery.	Battery needs to be charged.	Charge battery. If the battery won't hold a charge, replace the battery.
<b>oFL</b>	Overflow indication. The pressure being measured is outside the maximum measurement capability.	Pressure being measured is too high or low.  Pressure sensor damaged or defective.	Remove pressure source.  Return to TPI for service.
<b>oFL</b>	Overflow indication. The temperature being measured is outside the maximum measurement capability.	Temperature being measured is too high or low.	Remove pressure source.
<b>oPEn</b>	Unable to read thermocouple (temperature).	Temperature probe not connected to input. Worn temperature sensor.	Connect temperature probe to analyzer. Replace temperature probe or flue probe.

\*Sensor replacement requires calibration gas.

## Appendix E: ERROR CODES & TROUBLESHOOTING (Continued)

Problem	Possible Cause	Corrective Action
Efficiency reading incorrect	NET efficiency selected.  Ambient temperature probe not plugged in to T2.  Incorrect fuel selected.	Select GROSS efficiency. See section 5.3.  Plug ambient probe into T2. See section 5.2.  Select the proper fuel for the equipment being tested. See section 4.1.
Readings are erratic when working on oil fired equipment.	Oil filter not installed or installed incorrectly.	Make sure the optional oil filter (A773) is installed. See Appendix D.
One or all of the following parameters; Ratio, CO air free, excess air, and efficiency read and print dashes.	Measured values are such that the calculated values of these parameters are out of range.	Redo combustion test. Since these are calculated values, the measure values must be within certain levels for these to display. If the measured oxygen level is above 19.9% these parameters won't read.  These parameters might not display or be applicable in some tests.
Pressure prints as "N/A" on my combustion analysis print out.	During combustion analysis the pressure function is disabled. The manometer feature is a separate function and must be printed separately.	Perform the combustion test and then perform a pressure test. Save each test in a different location and print each test.
Battery will not charge or hold a charge.	Defective charger or battery.	Replace the charger or battery.  Send to TPI for service.
Beeping noise heard during charging.	Defect in charging circuit or shorted battery.	Disconnect from the charger and contact TPI at 800-368-5719.
Analyzer won't turn off	Oxygen and/or carbon monoxide levels outside limits.	Allow the analyzer to purge longer.

## Appendix F: CO ALARM & AUTO OFF SETTINGS

### Setting the Carbon Monoxide Alarm Point and/or Auto Power Off Mode

The CO alarm and auto power off settings can be changed as necessary by performing the following procedure.

**WARNING :** Changing parameters in field calibration mode can adversely affect the operation of your analyzer. Follow the instructions carefully.

1. Press and hold the Scroll/Enter Key down until 'FILD CAL' is displayed. The 712 will cycle through a 30 second countdown then display 'CAL', 'Air', 'gAS'.
2. Use the Up Arrow Key to select 'Air' by making it blink. Press the Scroll/Enter Key to accept the selection.
3. 712 Display: 'CAL', 'FLo', 'oPEn'. Action : Press the Func Key to bypass.
4. 712 Display: 'CAL', 'FLo', 'CLoS'. Action : Press the Func Key to bypass.
5. 712 Display: 'CAL', 'LEAK', 'rEF'. Action : Press the Func Key to bypass.
6. 712 Display: 'Oppm', 'Co', 'rEF'. Action : Press the Func Key to bypass.
7. 712 Display: '20.9%', 'o2', 'rEF'. Action : Press the Func Key to bypass.
8. 712 Display: '0.0mbar', '0.0', 'oFS'. Action : Press the Func Key to bypass.
9. 712 Display: '2000', 'A-r', 'SEt'. Action : If you are not changing the CO alarm point press the Func Key. Otherwise press the Up and Down Keys to set the ppm level the alarm will sound at. Factory default is 2000ppm. Press the Scroll/Enter Key to accept the selection.
10. 712 Display: 'Auto', 'oFF', 'En'. Action : If you are not changing the auto power off mode press the Func Key. Otherwise press the Up and Down Arrow Keys to enable (En) or disable (dis) the auto off function. Factory default is enabled (En). Press the Scroll/Enter Key to accept the selection.
11. 712 Display: 'CAL', 'StoP', 'go'. Action : Press the Up Arrow Key to select 'StoP' by making it blink and press the Scroll/Enter Key to accept the selection. The 712 will return to normal operation

## Appendix G: MANUALLY INITIALIZING SENSORS

## Notes:

### Manually Initializing the Carbon Monoxide and Oxygen Sensors

If the CO or O2 sensor fails to initialize, this procedure can be performed to try and manually initialize the sensor(s).

**WARNING** : Changing parameters in field calibration mode can adversely affect the operation of your analyzer. Follow the instructions carefully.

1. Press and hold the Scroll/Enter Key down until 'FILD CAL' is displayed. The 712 will cycle through a 30 second countdown then display 'CAL', 'Air', 'gAS'.
2. Use the Up Arrow Key to select 'Air' by making it blink. Press the Scroll/Enter Key to accept the selection.
3. 712 Display: 'CAL', 'FLo', 'oPEn'. Action : Press the Func Key to bypass.
4. 712 Display: 'CAL', 'FLo', 'CLOs'. Action : Press the Func Key to bypass.
5. 712 Display: 'CAL', 'LEAK', 'rEF'. Action : Press the Func Key to bypass.
6. 712 Display: 'Oppm', 'Co', 'rEF'. Action : Press the Scroll/Enter Key. After the 10 second countdown is complete press the Scroll/Enter Key twice.
7. 712 Display: '20.9%', 'o2', 'rEF'. Action : Press the Scroll/Enter Key. After the 10 second countdown is complete press the Scroll/Enter Key twice.
8. 712 Display: '0.0mbar', '0.0', 'oFS'. Action : Press the Func Key to bypass.
9. 712 Display: '2000', 'A-r', 'SEt'. Action : Press the Func Key to bypass.
10. 712 Display: 'Auto', 'oFF', 'En'. Action : Press the Func Key to bypass.
11. 712 Display: 'CAL', 'StoP', 'go'. Action : Press the Up Arrow Key to select 'StoP' by making it blink and press the Scroll/Enter Key to accept the selection. The 712 will return to normal operation

**If the 712 continues to fail to automatically initialize or this procedure fails to initialize the sensors, return your analyzer to Test Products International.**

**Notes:**

**Notes:**

**Test Products International, Inc.**

9615 SW Allen Blvd., Ste. 104

Beaverton, OR 97005

Tel: 503-520-9197 Fax: 503-520-1225

[www.tpi-thevalueleader.com](http://www.tpi-thevalueleader.com)

**Test Products International, Ltd.**

342 Bronte Road South, Unit #9

Milton Ontario Canada L9T5B7

Tel: 905-693-8558 Fax: 905-693-0888