

 **Spartan**  
owner's manual



Battery Powered Portable Sound System

**Touchboards**

**TeachLogic**  
FOR SOUND LEARNING 

### notes

Date of Purchase: \_\_\_\_\_

Model Number: \_\_\_\_\_

Serial Number: \_\_\_\_\_

Notes:



## contact

If you should encounter some unresolved issue, please contact TeachLogic customer service department for further assistance.

☎ 1-800-588-0018  
✉ sales@teachlogic.com  
☎ 1-760-631-1283  
🌐 www.teachlogic.com

## thank you

Congratulations on the purchase of your new Spartan Sound System. You can be assured that the Spartan complies with all specifications and was manufactured to very high quality control standards. TeachLogic incorporates state of the art technology, employs the most advanced manufacturing methodology and uses only premium quality components to assure many years of reliable performance. We appreciate your confidence by your selection of our product. It is TeachLogic's intent to uphold that confidence by providing factory assistance and dealer support.

We hope you will take the time to view this manual to familiarize yourself with the product features and its operation. This manual will help you learn to use and gain the maximum benefit of the Spartan system. The manual provides a basic explanation on the principles of RF transmission and its advantages. Followed by the system description, operation and installation instruction. The manual will conclude with maintenance and troubleshooting procedures.

Brian Van Waay

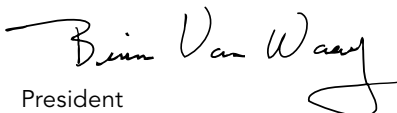

President

## safety instructions

### Read Instructions

All safety and operation instructions should be read before operating this TeachLogic product.

### Retain Instructions

Safety and operating instructions should be kept for future reference.

### Water & Moisture

This product should not be operated near water or excessively moist area.

### Heat Environment

Do not subject this product to excessive heat conditions.

### Power Source

This product must be connected to an AC power source per the voltage input specified and marked on the power supply.

### Power Cord Caution

Power cable should be routed clear of foot traffic and supported clear of kinking or abrasion.

### Object Protection

Locate the operating unit so it will not be subjected to falling objects or water entry.

### Proper Installation

Adhere to safe positioning to avoid falling, dismounting, head clearance, or cord cable obstruction

### Internal Service

User should not attempt to service this product. A qualified technician must accomplish all internal service.

### Electric Shock

Do not adapt or modify the AC power plug thus lifting the earth ground connection.



**CAUTION**



**RISK OF ELECTRIC SHOCK:  
DO NOT OPEN**

Caution: To Reduce The Risk Of Electric Shock Do Not Remove Cover (Or Back)  
No User-serviceable Parts Inside  
Refer Servicing To Qualified Personnel

## certifications



US



CA

Listed



TeachLogic systems are manufactured using lead-free processes and are free of materials harmful to the environment. They conform to the most stringent new European guidelines for consumer products (RoHS).

## caution

Recycle—Do not dispose of rechargeable batteries in trash. Actually it is unlawful to do so in CA, NY & ME.

Contact: Earth911.com

1-800-CLEANUP

Save our resources and don't contaminate.

Go Green

## table of contents

About the Spartan.....	1
Spartan Features and Functions.....	2
Operating Procedure.....	3-4
Lead Acid Battery.....	5-6
Handheld Transmitter.....	7-8
Body-Pack Transmitter.....	9-10
Optional Microphones.....	11-12
Battery Chargers.....	13-14
Tips for Best Results.....	15
Troubleshooting.....	15-17
Accessories.....	18-19
Specifications.....	20
Three Year Limited Warranty.....	21



### about the Spartan

The Spartan is a portable battery /AC operable sound system with a 20 watt (RMS) amplifier. Its resilient 4" coaxial speaker produces exceptional projection with outstanding clarity. The USB port reads MP3 files for playback of recorded program material, and in addition, the Spartan has a cabled microphone input, auxiliary line input, tone control and external speaker output.

Whether permanently mounted or toted about, the Spartan can always give full performance either plugged into AC power or by its internal rechargeable battery. The Spartan is ideally suited for voice reinforcement in a classroom, conference center or covering an assembled crowd outdoor.

A featured option, is the Spartan with a 96 channel wireless receiver to accommodate a 96 channel wireless microphone; either as a body-pack or handheld configuration.

#### *Unique Application for the Spartan*

The wireless receiver in the Spartan is compatible with the AirLink (ALS-960) transmitter. With AirLink plugged into an installed system, the Spartan can be an ideal wireless sound extension to any remote location. Such as providing sound in another room or keeping the crowd informed at the concession stand.

In addition, the Spartan is compatible with the Titan's AirLink (TX-750) transmitter to provide sound to a remote location or as a monitor at an isolated area.

### Spartan models

#### **SP-300**

Spartan Portable Sound System without the wireless receiver

#### **SP-300W**

Spartan Portable Sound System with a UHF 96 Channel Receiver

#### **SP-300BP**

Wireless Spartan SP-300W with a Body-Pack Transmitter and Microphone

#### **SP-350**

Wireless Spartan SP-300W with a Handheld Microphone/Transmitter

#### **SP-301**

Spartan unpowered Companion Speaker

## Spartan features and functions

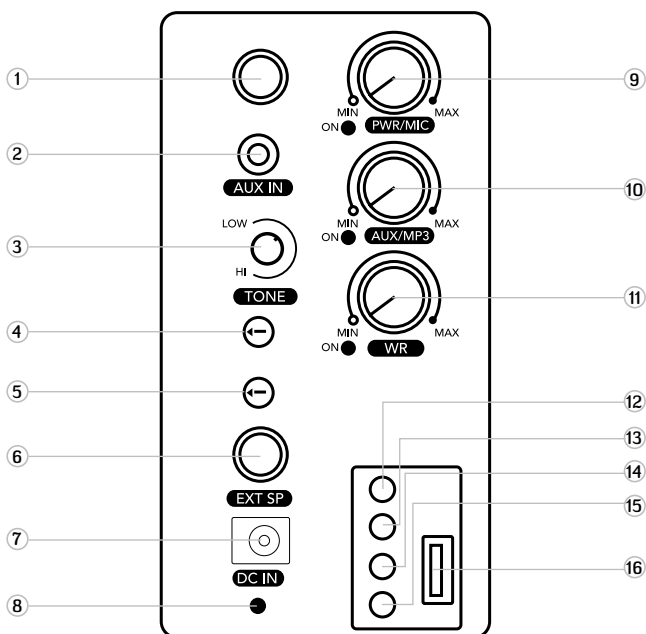

### SP-300W back panel

- |   |   |
|---|---|
| 1 Cabled Mic Input (1/4" phone jack)          | 9 Power Switch & Mic Volume               |
| 2 Aux Line Level Input (3.5mm jack)           | 10 Aux Input & MP3 Volume Control         |
| 3 Tone Control $\pm 6$ dB                     | 11 Wireless Receiver Power/Volume Control |
| <i>Wireless Receiver Frequency Selector:</i>  |   |
| 4 Decade Select (10–100)                      | <i>MP3/USB Controls:</i>                  |
| 5 Digit Select (0–9)                          | 12 Play/Pause                             |
| 6 External Speaker Output (1/4" phone jack)   | 13 Mode                                   |
| 7 Power Input: AC Operation, Recharge Battery | 14 Reverse                                |
| 8 Battery Charge Indicator (LED)              | 15 Forward                                |
|   | 16 MP3 Player/USB Port                    |

### initial procedure

- Locate power supply and plug it into an AC outlet
- Plug power supply into unit and observe LED
- Flashing "Red" LED indicates battery is being charged
- (Although fully charged at time of shipment, it is a good practice to fully charge battery)
- "Green" LED indicates battery is fully charged and unit is ready for use
- After 2-3 hours of use, LED will glow "Red" indicating battery needs recharging
- Power supply may be plugged in for continued use
- Power supply will simultaneously recharge battery (4–6 hours)





## operating procedure

**Turn unit "on": Turn Power/Mic control clockwise until click: Adjacent LED will light "Red"**

### operate using the cabled microphone

- Use a dynamic microphone (no phantom power available)
- Plug the microphone into the MIC IN jack
- Adjust volume with power/mic control while talking into microphone

### operate using wireless microphone

- Turn Wireless Receiver Power/Volume control (WR) clockwise until click
- Adjacent LED lights "Red"
- Select the frequency to match the transmitter frequency
  - Select Decade: 10–90 (Upper selector switch)
  - Select Digit: 0–9 (Lower selector switch)
- Adjust volume with WR control while talking into the wireless microphone



### note

USB format must be either "FAT" or "FAT 32" (Will not work with iPod)

### caution

Only remove USB 2.0 with player turned "off" or in PAUSE mode

**DO NOT REMOVE USB 2.0 WHILE PLAYER IS IN PLAY MODE**

### operate the USB digital player

- Turn Aux/MP3 Power Volume control clockwise until click
- Adjacent LED lights "Red"
- Insert USB 2.0 into Port (MP3 will commence playing automatically)
- Adjust volume to desired level (Aux/MP3 control)
- Press "PLAY/PAUSE" button (MP3 will stop)
- Press "PLAY/PAUSE" button again and playing will resume
- MODE Button: Selects program folders 1,2,3,4
  - Initial play will commence in folder 1
  - Press MODE button to advance to next folder
- Press |<< to select file (song) in folder
- Hold down for fast reverse
- Press |>> to select file (song) in folder
- Hold down for fast forward

### charging the battery

The Spartan contains one 12V/2.7 AH maintenance-free lead acid rechargeable battery.

#### charging battery

- Observe Battery Indicator when Spartan is turned "on"
- "Green" LED: Battery is fully charged
- "Red" LED: Battery is weak and needs to be charged

#### Charging battery:

- Plug in AC power supply, charging will start automatically
- While charging: LED Indicator will flash "Red"
- Completion of charge: LED Indicator will change to "Green"

#### caution

Battery needs to be re-charged soon after use to prevent damage to battery

Lead acid batteries can be recycled over 200 times  
Service per charge: 2–3 hours at moderate level.  
Life expectancy is one to two years (Replacement cost: \$55.00 as of 1/1/10).

#### lead acid batteries

- Do not form a memory barrier
- Can be charged at any state of charge condition
- Can be recharged hundreds of times
- Can be left plugged in continuously
- Recharge immediately after use for best performance and prolonged lifespan
- Recharge monthly minimum
- Evidence of battery life expiring: decrease in service per charge, distorted sound, will not accept recharge

## lead acid battery guidelines

1. Battery should operate at temperatures between 59°F–122°F. When temperature falls to 5°F, battery will undergo some changes in its chemical contents and therefore cannot be recharged. Operating the battery at higher temperature will result in higher capacity but shorter lifespan, whereas lower temperature operation has a longer lifespan but less capacity.
2. If the battery is not recharged within 72 hours after it has reached complete exhaustion, it will be permanently damaged.
3. The battery's cycle lifespan (number of charge and discharge cycle) is determined by the degree at which power is dissipated; especially the degree of discharge each time it is used and the recovery charging method. For normal use, the battery can be used for longer hours when less power is dissipated each time and vice versa. At 77°F, maintenance-free batteries could be charged 150–200 times for 100% discharge each time.
4. Decrease in capacity, internal short circuit, deformation in appearance, erosion of charged ends and decrease in open circuit voltage are symptoms indicating battery is approaching the end of its life cycle.

## handheld microphone/transmitter

The handheld microphone/transmitter is equipped with a dynamic microphone element for enhanced clarity and extended dynamic range. Its low handling noise and built-in windscreen makes it well suited for close-up handheld use. It can be powered by either Alkaline or rechargeable NiMH batteries. The rechargeable batteries can be recharged either in the drop-in charger or with the plug-in charger.

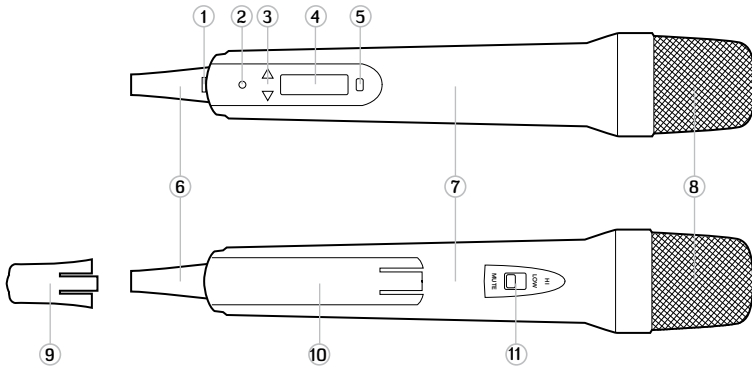

## UT-96HH

- |                            |  |
|----------------------------|--|
| 1 Power "on/off" switch    | 7 Soft comfort, non-slip body                    |
| 2 LED power "on" indicator | 8 Protective screen head                         |
| 3 Up/down frequency select | 9 Color identity end cap                         |
| 4 LCD readout              | 10 Battery compartment                           |
| 5 Frequency set button     | 11 Microphone sensitivity:<br>HI/LOW/MUTE select |
| 6 Charging port connection |  |

## handheld transmitter operation

1. Be sure the microphone is switched off before inserting batteries.
2. Remove lower identity cap.
3. Remove lower battery compartment door.
4. Insert two (2) AA batteries (use only alkaline or fully charged NiMH batteries).  
**Caution:** Be sure to observe correct polarity
5. Replace lower battery compartment door.
6. Locate power switch at base of microphone (small gray button)

## danger

DO NOT ATTEMPT TO  
CHARGE ALKALINE BATTERIES

## handheld transmitter operation (cont.)



### FCC regulation

RF transmission equipment must comply with FCC regulations. All TeachLogic transmission devices comply with Part 15 of the FCC rules and operate in the UHF frequency range in the 640–664 MHz frequency range. Power output is limited to less than 50 milliwatts to prevent any interference with any other RF operated equipment.

7. Press upward and hold the power switch for 2-3 seconds.
8. Power LED will illuminate "Red" and "On" will be displayed in the LCD screen.
9. LCD window will also display: Battery condition and CH #
10. A microphone sensitivity selection switch provides three modes of microphone sensitivity (HIGH, LOW, MUTE)
  - MUTE: Mutes microphone "off" while retaining transmission and RF connection
  - LOW: Use when microphone is held close to mouth or strong vocal input
  - HIGH: Use when additional sensitivity is required for softer voice
11. LCD screen displays the channel number selected for the microphone.  
To display channel frequency: Press and hold the UP or DOWN select button.
12. To change channel selection
  - Press and hold frequency SET button for 2 seconds. LCD panel will commence flashing (indicating programming mode)
  - Press UP or DOWN arrow to select channel desired
  - Press SET button to lock in channel selected
13. The battery status is displayed on the left of the LCD screen.
  - When battery nears depletion: Icon will flash 3 times
  - Microphone will automatically turn "off" to prevent damage
14. To turn microphone "off", press and hold the power switch until the LCD screen displays "OFF".

## body-pack transmitter

The Body-Pack Transmitter is the component that transmits the voice to the Spartan receiver. The audio is transmitted via an RF signal on a selected RF frequency. An external microphone is plugged into the Body-Pack Transmitter which picks up the speaker's voice. The microphone can be either a Lapel, Collar style or a Headset with a boom microphone. The transmitter is usually worn on the waist utilizing the wire belt clip, however; it can be placed in your pocket if it is more convenient. The Body-Pack is battery powered and requires two "AA" size batteries.

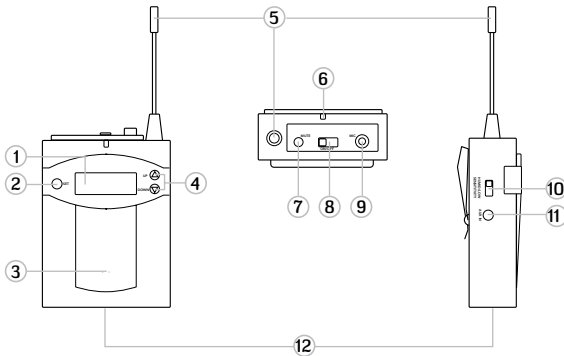

## UT-96BP

- |  |  |
|--|--|
| 1 LCD display                          | 8 Power "ON/OFF" switch                                  |
| 2 Frequency SET button                 | 9 MIC input jack (3.5mm)                                 |
| 3 Built-in microphone for handheld use | 10 Microphone input sensitivity selection switch (L,M,H) |
| 4 UP/DOWN channel select buttons       | 11 AUX input jack (3.5mm)                                |
| 5 Transmitting Antenna                 | 12 Charging jack   |
| 6 Power "On" LED indicator             |  |
| 7 Microphone mute button               |  |

## body-pack transmitter operation

1. Ensure microphone is switched off before inserting batteries.
2. Remove battery compartment cover.
3. Insert two "AA" batteries, observing polarity (alkaline or rechargeable NiMH).
4. Plug in microphone: Lapel, Headset w/boom, Collar or UltraLite mic.

**danger**

DO NOT ATTEMPT TO  
CHARGE ALKALINE BATTERIES

## body-pack transmitter operation (cont.)



### FCC regulation

RF transmission equipment must comply with FCC regulations. All TeachLogic transmission devices comply with Part 15 of the FCC rules and operate in the UHF band in the 640–664 MHz frequency range. Power output is limited to less than 50 milliwatts to prevent any interference with any other RF operated equipment.

5. Push power switch to “ON”. Top power LED will illuminate “Red”
6. “On” will be displayed in the LCD screen.
7. LCD window will display: Battery condition and CH #
8. A selection switch on the side of the body-pack provides three levels of microphone sensitivity (HI/MID/LOW)
  - High: Most sensitive position for weak voice or distant microphone to mouth.
  - Mid: When the microphone used is further away from mouth, such as: a collar or lapel microphone is clipped on clothing away from mouth
  - Low: When microphone is used close to mouth, such as; a headset with a boom microphone or with a very strong vocal performer.
9. MUTE Button: Mutes microphone “off” while retaining transmission and RF Connection
10. Internal Microphone:
  - Locate two small hole on front of transmitter
  - Hold transmitter in front of mouth and speak into it.
11. LCD screen displays the transmission channel number and battery condition
12. To display channel frequency: Press and hold UP or DOWN button.
13. To change channel selection
  - Press and hold frequency SET button for 2 seconds
  - LCD panel will commence flashing (indicating programming mode)
  - Press UP or DOWN arrow to select channel desired
  - Press SET button to lock in channel selected
14. The battery status is displayed on the left edge of the LCD screen.
  - When battery nears depletion: Icon will flash 3 times
  - Transmitter will automatically turn “off” to prevent damage
15. To turn microphone “Off”; push power switch to “OFF”.

### optional microphones for body-pack transmitter

Any of the microphones below may be used with the Body-Pack Transmitter.

#### LM-835 lapel microphone

The Lapel Microphone (LM-835) is a small capsule microphone with a spring clip for securing it on to a clothing edge. The lapel microphone renders excellent vocal reproduction. The lapel microphone is less obtrusive to the user and least visible. However, due to the greater distance from mouth to microphone it will require additional gain. As a result it is more prone to feedback. So adjustment of volume is more critical, especially near or under a speaker.



#### HBM-935 headband microphone

The Headband Microphone (HBM-935) is worn around the head with a unidirectional microphone located on the end of a flexible boom. This is the best performing microphone due to its unidirectional mic element and its always close proximity to the mouth. The microphone also renders maximum gain and is least prone to feedback.



#### CM-835 collar microphone

The Collar Microphone (CM-835) is a flexible rod that can be formed to fit around the neck. The end with the microphone is then contoured up toward the mouth. The cord exits the flexible rod from the back, out of the way. The collar microphone utilizes a unidirectional element for excellent voice reproduction and minimizes feedback.







### ULM-835 ultra-lite microphone

The Ultra-Lite Microphone (ULM-835) is a miniature boom style microphone supported by a wire around the left ear. The unidirectional microphone element renders excellent vocal quality and maximum clarity. Its lightweight and miniature size make it comfortable and inconspicuous. It is available in either beige or black.

#### caution

The boom can be formed to fit but it is not considered to be flexible.

So it cannot be bent back and forth; IT WILL BREAK!



### LM-300 plug-in microphone w/ lanyard

The Plug-in Microphone (LM-300) is a small capsule size microphone that plugs directly into the top of the Body-Pack. With the adjustable lanyard, the Body-Pack can be worn around the neck as a pendant style microphone. The Body-Pack is easily removed from the lanyard to facilitate use as a handheld microphone.

### battery chargers

#### BRC-10 operating instructions

- Use "AA" rechargeable NiMH batteries only
- Plug adapter into 110v AC outlet.
- Remove color identification cap.
- Plug cable into jack at the base (bottom end) of transmitter
- Turn Handheld Transmitter "On" to observe battery icon
- During charging, the battery icon will cycle through the charge "block"
- When fully charged, battery icon will display all "blocks" filled
- Charging time; typically 10-12 hours
- Turn Handheld Transmitter "Off" and reinstall color identification cap.





## BRC-70 operating instructions

- Use "AA" rechargeable NiMH batteries only in microphones
- Plug power adapter in 110v AC outlet.
- Plug cable into base of charger
- Charging Handheld Microphone/Transmitter
  - Remove color identification cap from Handheld microphone, store on cap holder
  - Insert Handheld microphone into small square receptacle
  - Push down firmly in place
  - Charging Handheld Indicators (Handheld symbol)
    - "on" indicator LED lights "Amber" when charging
    - "ok" indicator LED lights "Green" when fully charged
- Charging Body-Pack Transmitter
  - Insert Body-Pack into Front/Large receptacle
  - Push down firmly in place
  - Observe front with LCD facing forward (toward you)
  - Charging Body-Pack Indicators (Body-Pack symbol)
    - "on" indicator LED lights "Amber" when charging
    - "ok" indicator LED lights "Green" when fully charged
- Charging time; typically 10-12 hours.
- During normal charging the battery icon will cycle through the charge "block" icons
- Remove transmitters when charging is complete
- Reinstall color identification cap on handheld
- Turn transmitter "On", verify battery icon in LCD window shows all blocks filled

### caution

- Do not subject to moisture or high temperature.
- Keep charging pins clean and dust-free.
- Do not attempt to charge non-rechargeable batteries.
- Do not mix up old and new batteries to charge.
- Use only the power adapter that came with the unit.

## tips for best results

1. Make sure batteries are inserted per correct polarity
  - Positive Terminal (+) downward toward base in Handheld)
  - Positive Terminal (+) away from spring in Body-Pack
2. Use only new high-quality alkaline or rechargeable NiMH batteries in the transmitter.
3. When batteries are weak, replace all the batteries at the same time. Do not mix and use new and old batteries together.
4. Observe the area between Microphone/Transmitter and Receiver. Minimize obstructing metal objects, i.e. metal fence, cars, steel structure, etc. (Line of sight is best)
5. A receiver can only receive one transmission signal. Cannot turn "On" two wireless microphones on same frequency (channel) simultaneously.
6. Turn the transmitter off when it is not in use.
7. Remove the batteries when not used for a length of time.

## BRC-70 charger troubleshooting

Problem	Solution
Amber indicator does not light	<ul style="list-style-type: none"> <li>• Please check if batteries are inserted correctly. Also check if the probes were covered by dust, or any deformation caused to it.</li> </ul>
Amber indicator twinkles	<ul style="list-style-type: none"> <li>• Please check if the batteries are rechargeable, or misallocated.</li> </ul>

## Spartan troubleshooting

Problem	Solution
No sound when one speaks into the wireless microphone	<ul style="list-style-type: none"><li>• Verify MIC /Power switch "On", LED light "Red"</li><li>• If battery is either weak or not charged, plug power supply into the AC</li><li>• Verify WR switch/volume turned "On", adjacent LED light "Red"</li><li>• Verify channel selection is the same for microphone and receiver</li><li>• Verify power on transmitter indicate good or fully charged batteries</li></ul>

## handheld transmitter troubleshooting

Problem	Solution
Power LED does not illuminate after pressing power switch	<ul style="list-style-type: none"><li>• Ensure you held power switch in place for 2-3 seconds</li><li>• Verify batteries are good or charged and inserted correctly.</li></ul>
LCD shows "Err" or garbled information when switching off	<ul style="list-style-type: none"><li>• Restart transmitter</li><li>• Remove batteries and re-insert them</li></ul>

### contact

If your problem persists and this guide has not resolved the issue, call our customer service department for additional assistance. (800) 588-0018

## body-pack transmitter troubleshooting

Problem	Solution
Power LED does not illuminate after switching on	<ul style="list-style-type: none"> <li>• Verify batteries are good or charged and inserted correctly</li> </ul>
LCD shows "Err" or garbled information	<ul style="list-style-type: none"> <li>• Restart transmitter</li> <li>• Remove batteries and re-insert them</li> </ul>
Distorted Sound	<ul style="list-style-type: none"> <li>• Low charge on Spartan battery (Plug in AC power supply and recharge)</li> <li>• Low microphone/transmitter battery (Replace or charge batteries)</li> <li>• Interference (Change wireless channel)</li> <li>• Intermittent interference (Change wireless channel selection)</li> <li>• Auxiliary input overloading (Reduce volume on input device)</li> <li>• Check sensitivity position on microphone</li> <li>• Exceeding range or interfering objects (Improve wireless microphone transmission condition)</li> </ul>

## contact

**If your problem persists and this guide has not resolved the issue, call our customer service department for additional assistance. (800) 588-0018**

## accessories



### CC-40 carrying/protective case

The CC-40 is a soft/fitted case with a carrying handle and over the shoulder strap. The mesh front and velcro'd rear panel permit accessories operating the Spartan in its case. Side compartments allow convenient storage of microphone, power supply and program material.



### SR-30 mounting bracket

A versatile mounting bracket to mount the Spartan on the wall or from the ceiling. The universal joints permit orienting the Spartan in any direction. The release clamps allow easy/quick dismounting.



### ST-30 folding tripod speaker stand

The speaker stand can be adjusted from 32" to 55" and folds down to 3" dia. by 32". The Spartan is securely screwed on by the 3/8" brass threaded insert.

### accessories

#### SP-301 unpowered companion speaker

Companion speaker exactly the same as the Spartan for additional even sound coverage.



#### SC-30 speaker cable

Speaker cable with ¼" phone plug on each end, 30 feet length.



#### UM-66 handheld microphone w/ 15' cable

Handheld dynamic microphone for simultaneous use with the wireless microphone. The ¼" phone plug plugs directly into the MIC IN jack. The wired MIC IN has its own independent volume control. So you can truly have a two microphone system. The microphone has very low handling noise, a built-in breath filter and wide dynamic range.





### Spartan 300 specs.

Output Power	20W (RMS)/4Ω load, Max 30W
Speaker System	4" full range
Frequency Response	50Hz–15KHz ± 3dB
Antenna	Built-in
T.H.D.	< 0.5 %
Audio Inputs	Mic in, Aux in, USB 2.0
Audio Output	Ext. Speaker
Power Supply Type	120–240 V 1.5A, 15V 4A
Rechargeable Battery Type	12 V/2.7 AH
Operating Life	about 4–6 hours
Charging Time	about 4 hours
Dimension	9.59"(H) x 5.5" (W) x 5.5" (D)
Weight	5.95 lbs.
Approval	CE, FCC, RoHS

### body-pack transmitter (UT-96BP) specs.

Mic Capsule	Condenser
RF Output	10mW
Spurious Emission	<250mW
Audio Input	Mic in, Aux in
AF Controls	Mute switch, hi/mid/lo switch
Battery	1.2V NiMH rechargeable x 2 or 1.5V Alkaline x 2
Operating Life (fully charged)	11 hrs (NiMH) or 14 hrs (Alkaline)
Dimensions	4.5" x 2.5" x 1"
Weight (with batteries)	170g

### handheld transmitter (UT-96HH) specs.

Mic Capsule	Dynamic
RF Output	10mW
Spurious Emission	250mW
AF Controls	Hi/lo/mute switch
Battery	1.2V NiMH rechargeable x 2 or 1.5V Alkaline x 2
Operating Life (fully charged)	11 hrs (NiMH) or 14 hrs (Alkaline)
Dimensions	1.80" x 10.39"
Weight (with batteries)	280g

### three year limited warranty

TeachLogic RF products are guaranteed to be free of defects in workmanship or material for a period of three (3) years from date of original purchase, subject to the following conditions:

1. Warranty excludes defects caused by normal use and wear, any abuse, or failure to use the product in accordance per instructions.
2. Warranty is void if damage occurred because of misuse, or attempted repair or modification by unauthorized personnel.
3. Warranty on cables, and cable connections are limited to one (1) year.
4. Warranty on batteries is for ninety (90) days.
5. Warranty on microphones and microphone elements are limited to one (1) year.
6. Warranty does not extend to finish or appearance past ninety (90) days.
7. All warranty service will be provided by TeachLogic or authorized service center
8. Warranty is made to the original purchaser and may not be transferred to another user.
9. Warranty service rendered will be on a repair or replacement basis, whichever TeachLogic deems to be most prudent for customer satisfaction and economic feasibility.

TeachLogic will only accept warranty shipments accompanied by Return Authorization Number previously assigned by TeachLogic personnel. Advance warranty replacements will be made per the discretion of TeachLogic personnel.

TeachLogic will pay return shipping cost on all warranty repairs or replacements.

### contact

TeachLogic, Inc.  
Customer Service Dept.  
1688 Ord Way  
Oceanside, CA 92056

☎ 1-800-588-0018

✉ sales@teachlogic.com

☎ 1-760-631-1283

🌐 www.teachlogic.com



TeachLogic  
FOR SOUND LEARNING 

TeachLogic, Inc.

**Touchboards**