



## Transmation

### Easy to use

The Transmation CheckMate 100 will check, calibrate and measure all your current signal instruments in a 4 to 20 milliamp DC loop. Use at every point in your loop. Source & read 0.00 to 24.00 mA, simulate a 2-wire transmitter or the use the CheckMate 100 to simultaneously power & measure your 2-wire transmitters. Toggle the display to show milliamps or percent of 4 to 20.

### Source milliamps

Calibrate recorders, digital indicators, stroke valves or any other instruments that get their input from a 4 to 20 mA loop. Easily set any value to within 0.01 mA with the intuitive UP and DOWN pushbuttons. Separate buttons for each digit make adjustments fast and easy.

### Recall output settings

The "Quik-Chek" pushbuttons provide rapid checking of any three points in the 0.00 to 24.00 mA range. Quik-Chek settings remain in memory even when the CheckMate 100 is powered off.

### Calibrate using loop power

Check loop wiring and receivers by using the CheckMate 100 in place of a 2-wire transmitter. Simulate a changing process input to check loop response and control settings. The CheckMate 100 uses any loop power from 3 to 45 VDC.

### Read loop current

Check controller outputs or measure the milliamp signal anywhere in the loop. The CheckMate 100 measures 0.00 to 24.00 mA signals with much greater accuracy than a typical multimeter. Toggle the display to show milliamps or percent of 4 to 20.

Display the present reading, maximum or minimum by pressing the READ, MAX or MIN pushbuttons to see how the loop has varied or to check the stability of control.

### Power and measure 2-wire transmitters

Simultaneously measure the output of a 2-wire transmitter while using the internal batteries to supply up to 25 VDC to power the transmitter. Handy for checking transmitters in the field or on the bench.

## Milliamp Calibrator CheckMate™ 100



- Calibrates all milliamp instruments
  - Source milliamps
  - Simulate two-wire transmitters
  - Read milliamp outputs
  - Power & measure two-wire transmitters
- Compact and low cost
  - The CheckMate100 fits easily into your pocket and budget.
- Easy to use
  - One touch to set the output & function
- Accuracy to  $\pm 0.025\%$ 
  - Within  $\pm 0.02$  mA from 4 to 20 mA
- Long lasting alkaline batteries
  - Four "AA" Alkaline cells can provide months of typical use
- Settable "Quik-Chek®" pushbuttons
  - Set any HI and LO from 0 to 24 milliamps
- Milliamp or percent display
  - Source or Read from 0.00 to 24.00 mA or from -25.0 to +125.0% of 4 to 20 mA span

POWER

### Turn-on

Each time you turn on the CheckMate 100 the LCD will display all segments for about 1 second. It then displays the most recently selected source or read setting.

### Source

The three Quik-Chek outputs will be the same as previously stored. Each time a different function is selected, the three Quik-Chek outputs will be recalled.

### Read

The CheckMate 100 is ready to measure the same signal as the last time it was turned on and will automatically update the MAX & MIN readings for recall at any time.

### Selecting ranges

For some functions there are two or more ranges or scales. Press the RANGE/TYPE pushbutton to scroll through the ranges and scales. The ranges will scroll and will go back to the beginning after the last choice. When scaled in percent, 100.0% corresponds to 20.00 mA and 0.0% corresponds to 4.00 mA.

RANGE/TYPE

### Turn-off

Press the POWER push-button to turn the CheckMate 100 off. If AUTO-OFF is enabled, the CheckMate 100 will turn itself off after 30 minutes of inactivity.

POWER

### Autocal

To maintain accuracy, the CheckMate periodically recalibrates its measuring circuitry against internal references. While this is occurring the word CAL will appear on the display for less than 2 seconds.

CAL

### Changing batteries

Low battery is indicated by BAT on the display. Approximately four hours of operation remain before the LCD blanks and CheckMate 100 shuts itself down. Turn the CheckMate 100 off, loosen the captive screw securing the battery compartment and lift off the cover from the bottom of the case. The four "AA" batteries are easily removed and replaced (alkaline supplied and recommended). Replace the battery compartment cover and tighten the screws.

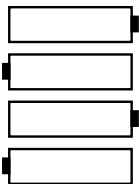

### Auto-off

CheckMate 100 can be set up to turn itself off after 30 minutes of inactivity. The internal timer is reset to 30 minutes each time a pushbutton is pressed. This configuration is part of the Default Settings below.

### Default settings – Auto-off

CheckMate 100 may be restored to the factory settings. This will reset the HI and LO "Quik-Chek" memories to 20.00 mA and 4.00 mA and the SET memory to midrange (12 mA). Prompts also guide you for selection of Auto-Off.

- 1) Press and hold the STORE/RESET push-button while turning the CheckMate 100 on.
- 2) Keep pressing the STORE/RESET push-button until the display flashes (about 5 seconds) then release.
- 3) The words BAT and ON will appear on the display indicating that AUTO-OFF is selected.
- 4) To toggle the AUTO-OFF function on and off press the RANGE/TYPE push-button and the words oN and oFF will display.
- 5) After five seconds the CheckMate100 will automatically store your choice and the CheckMate 100 will begin normal operation. Or you may press the STORE/RESET button to accept your choice and begin operation.

### Source milliamps

Select source by pressing the SOURCE/READ pushbutton until the word SOURCE appears on the LCD display. To change the output value press the UP or DOWN pushbutton corresponding to the digit being displayed. To ramp the output press and hold any UP or DOWN pushbutton. The display will continue to change in increments corresponding to the digit being changed and will automatically carry up and down until the limits of the range are reached. This function operates in all three output positions (HI, SET & LO).

### Storing Quik-Chek outputs

- 1) Press HI or LO
  - 2) Press the UP/DOWN keys to desired value
  - 3) Press the STORE push-button
- The LCD will flash once to show that the value was saved

If a value is in the SET position and you want that value stored in HI or LO, press and hold the STORE push-button, then press the HI or LO pushbutton. The display will flash once to indicate the value has been stored. Then release both pushbuttons.

HI / MAX

SET / READ

LO / MIN

STORE/RESET

### Recall Quik-Chek outputs

When you need a stored value just press the HI or LOW Quik-Chek pushbutton. Any value for the selected range may be stored in HI & LO. The CheckMate 100 remembers the HI, LO and SET values for each function with the power on or off. Each time a different function is selected, the last three Quik-Chek values for that function will be recalled.

Note: The same value is stored for both mA and % . The recalled value will be displayed in the units you have selected.

HI / MAX

SET / READ

LO / MIN

### Open loops

The digits on the LCD will flash if there is an open loop or if the polarity is reversed. Check all the connections in the loop or try reversing the leads.

### Read milliamps

Select read by pressing the SOURCE/READ pushbutton until the word READ appears on the LCD display. The READ functions measure the desired signal.

### Min/Max

To read the maximum or minimum input since read mode was entered, simply press the MAX or MIN pushbutton. The value will appear on the LCD along with the word MAX or MIN. The MAX/MIN values are automatically updated and may be viewed at any time without disturbing the other values.

HI / MAX

SET / READ

LO / MIN

### Restarting Min/Max

Pressing the STORE/RESET push-button will cause the CheckMate 100 to store the present reading into the MAX and MIN memories. Upon releasing the STORE/RESET push-button the CheckMate 100 will resume reading the input and update the MAX & MIN values as the measured signal changes.

STORE/RESET

### Out of range signals

Signals above or below those available for the currently selected range will be indicated by Or and Ur on the display.



## Source milliamps

mA, mA % (Percent of 4 to 20 mA)

Choose this function to provide an output from 0.00 to 24.00 milliamps. The compliance voltage is a nominal 25 VDC to provide the driving power to your milliamp receivers.

- 1) Disconnect one or both input wires from the device to be calibrated.
- 2) Press the POWER push-button then press the SOURCE/READ push-button until SOURCE is displayed.
- 3) Repeatedly press the RANGE/TYPE push-button until SOURCE and mA or SOURCE, mA and % are displayed.
- 4) Connect the red source lead of the calibrator to the plus (+) input of the device and the black source lead to the minus (-).

Output current is adjustable with the UP and DOWN push-buttons. Span and zero outputs are available by using the LO and HI Quik-Chek push-buttons to recall your stored settings (4.00 & 20.00 mA defaults).

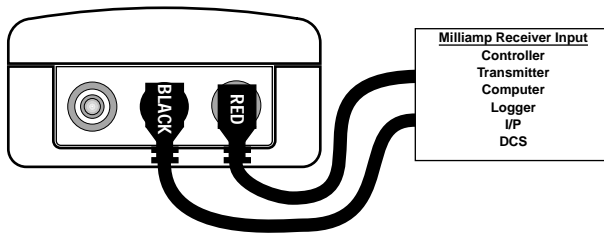

## Read milliamps

mA, mA % (Percent of 4 to 20 mA)

Choose this function to measure from 0.00 to +24.00 milliamps or -25.0 to 125.0%.

- 1) Open the current loop at any convenient point along the signal path
- 2) Press the POWER push-button then press the SOURCE/READ push-button until READ is displayed.
- 3) Repeatedly press the RANGE/TYPE push-button until READ and mA or READ, mA and % are displayed.
- 4) Connect the red read (+) lead of the calibrator to the more positive point of the break and the black read (-) lead to the more negative

Display the present reading, maximum or minimum by pressing the READ, MAX or MIN pushbuttons.

Signals above or below those available for the currently selected range will be indicated by Or and Ur on the display.

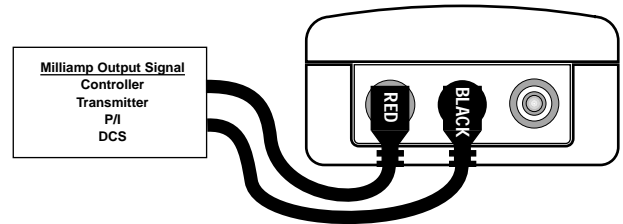

## Simulate 2-wire transmitters

2-WIRE SIM mA, 2-WIRE SIM % (Percent of 4 to 20 mA)

Choose this function to simulate a 2-wire transmitter output from 1.00 to 24.00 milliamps. Operates in loops with power supply voltages from 3 to 45 VDC.

- 1) Disconnect existing 2-wire transmitter from the loop
- 2) Press the POWER push-button then press the SOURCE/READ push-button until SOURCE is displayed.
- 3) Repeatedly press the RANGE/TYPE push-button until SOURCE, 2-WIRE SIM and mA or SOURCE, 2-WIRE SIM, mA and % are displayed.
- 4) Connect the red lead of the calibrator to the plus (+) input of the field connections and the black lead to the minus (-)

Output current is adjustable from 1.00 to 24.00 mA with the UP and DOWN push-buttons. Span and Zero outputs are available by using the LO and HI Quik-Chek push-buttons to recall your stored settings (4.00 & 20.00 mA defaults).

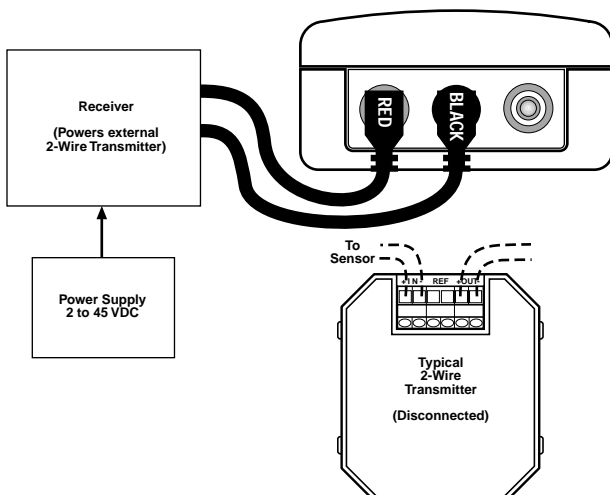

## Power and measure 2-wire transmitters

PWR XMTR mA, PWR XMTR %

Choose this function to simultaneously supply power to a 2-wire transmitter while displaying the 4-20 mA output of the transmitter.

- 1) Disconnect one or both input wires from the 2-wire transmitter to be calibrated
- 2) Press the POWER push-button then press the SOURCE/READ push-button until SOURCE is displayed.
- 3) Repeatedly press the RANGE/TYPE push-button until SOURCE, PWR XMTR and mA or SOURCE, PWR XMTR, mA and % are displayed.
- 4) Connect the red source lead of the calibrator to the plus (+) input of the device and the black source lead to the minus (-)
- 5) Connect an appropriate sensor or calibrator to the input of the 2-wire transmitter

The CheckMate 100 supplies a nominal 25 Volts DC at 24 mA to the 2-wire transmitter. The current passed by the transmitter will be accurately displayed by the CheckMate 100. Calibrate the transmitter in the usual manner and disconnect the CheckMate 100.

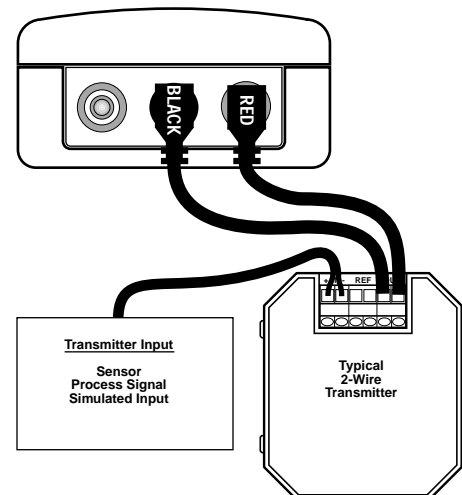

# Product Specifications

	<b>General</b>	
90 day accuracy	$\pm(0.025\%$ of Full Scale + 1 LSD)*	*Typical 90 day accuracy can be estimated by dividing the 1 year % of full scale accuracy by 2. Additions to the specification, such as + 1 LSD, remain constant.
1 year accuracy	$\pm(0.05\%$ of Full Scale + 1 LSD)	
Warm up time	10 seconds to specified accuracy, 2 minutes to maximum accuracy	
Temperature effect	$\pm 0.01\%/^{\circ}\text{C}$ based on $23^{\circ}\pm 25^{\circ}\text{C}$	
Batteries	Four "AA", (R6) batteries (Alkaline supplied and recommended)	
Battery life	Milliamp source & 2-wire modes: Nominal 24 hours at 12 mA, 16 hours at 20 mA with 250 Ohm load	
Low battery indication	Read milliamp: Nominal 40 hours	
Overvoltage protection	"BAT" indication on the display at approximately 4 hours left	
Operating temperature range	Protected to 120V AC/DC for 30 seconds	
Storage temperature range	-5 to +130 °F (-20 to +55°C)	
Relative humidity	-13 to +130°F (-25 to +55°C)	
Overall size	10 to 90%, non-condensing for 24 hours from 0 to 35°C	
Weight	158.1 x 83.1 x 49.3 mm (6.23 x 3.27 x 1.94 inches)	
	0.34 kg (12 oz)	
	<b>Milliamp source</b>	
Ranges	0.00 to 24.00 mA; -25.0 to 125.0 % of 4 to 20 mA	
Accuracy	$\pm(0.05\%$ of 24 mA Span + 0.01 mA) = 0.02mA	
Typical drive capability	1000 Ohms @ 20.00 mA	
Compliance voltage	nominal 25 V @ 20 mA	
	<b>Power &amp; measure 2-wire transmitters</b>	
Ranges and accuracy	Same as for MILLIAMP SOURCE	
Output current	Up to 24.00 mA	
Typical drive capability	1200 Ohms @ 20.00 mA	
Compliance voltage	nominal 25 VDC @ 20 mA	
	<b>2-wire transmitter simulator</b>	
Ranges	1.00 to 24.00 mA; -18.8 to 125.0% of 4 to 20 mA	
Accuracy	Same as for milliamp source	
Loop voltage limits	Minimum, 3 VDC; maximum 45 VDC	
Overload protection	Current limited to 25 mA nominal	
	<b>Read milliamp</b>	
Ranges	0.00 to 24.00 mA; -25.0 to 125.0 % of 4 to 20 mA	
Accuracy	Same as for MILLIAMP SOURCE	
Overload protection	Fused	
Voltage burden	0.9V at 4 mA, 1.2V at 20 mA, 1.9V at 24 mA excitation current	

## Warranty

Transmation products are warranted to be free from defects in material and workmanship (excluding fuses, batteries and leads) for a period of one year from the date of shipment. Warranty repairs can be obtained by returning the equipment prepaid to our factory. Products will be replaced, repaired, or adjusted at our option. *Transmation gives no other warranties, including any implied warranty of fitness for a particular purpose.* Also, Transmation shall not be liable for any special, indirect, incidental or consequential damages or losses arising from the sale or use of its products.

Ordering information  
CheckMate 100 Milliamp Calibrator

Part No.  
23400E

Included with each CheckMate 100 are:  
1 Pair of test leads with banana plugs and alligator clips  
Carrying Case

# TRANSCAT®

 Visit us at [Transcat.com!](http://Transcat.com!)

35 Vantage Point Drive // Rochester, NY 14624 // Call 1.800.800.5001