

**6966 HEAT GUN**

**READ SAFETY INSTRUCTIONS ON PAGE 3 BEFORE OPERATING HEAT GUN.**

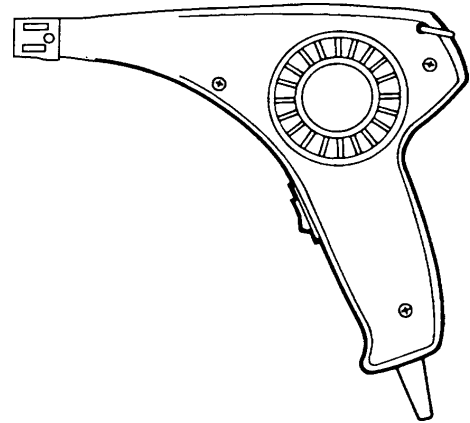

**OPERATION**

1. Connect power cord to main AC outlet. **(Do not use DC).**
2. Place appropriate baffle over nozzle of gun before turning power switch on.
3. The trigger power switch has three positions. The Hot Air (II) position will produce air temperature at nozzle of approximately 800°F in 10 seconds. **SWITCH TO COLD AIR 30-45 SECONDS BEFORE TURNING OFF.** This will increase the life of the heating element.

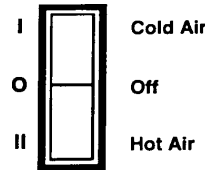

4. Keep nozzle at least 1/4" from the surface to be heated. Restricting the air flow from the nozzle may cause damage to your heating element. **CAUTION: Heat Gun should never be placed in a position where the stream of hot air is directed onto table surfaces or flammable materials.**
5. The Heat Guns may be operated in several positions.

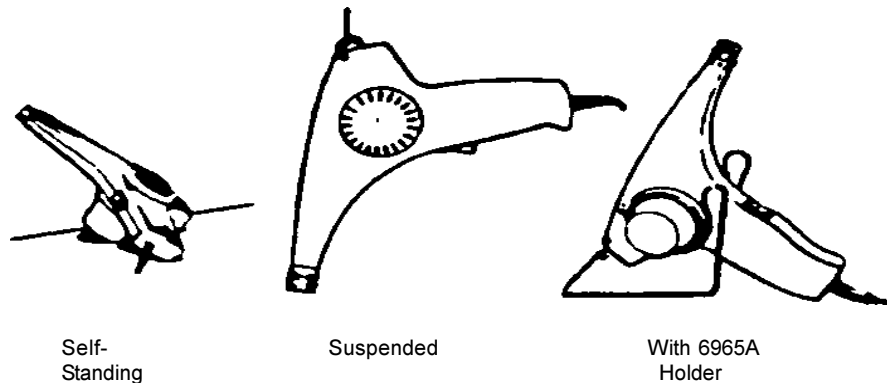

6. To remove or change baffles when hot, simply trigger power switch to Cool Air position (I); hold handle of gun in one hand and remove the hot baffle with a pair of long nose pliers.

**HEAT GUN BAFFLE ACCESSORIES**

**6956**  
**Shrink Tubing Reflector**  
 1/2" Reflector,  
 3/4" Diameter  
 Designed for general heat shrinking applications.

**6958**  
**Reducing Baffle**  
 For critical heat direction. Reduces air flow at nozzle to .200".

**6957**  
**Shrink Tubing Reflector**  
 1 1/4" Reflector,  
 3/4" Diameter  
 For larger shrinking applications.

**6964**  
**Precision Reflector**  
 Designed for shrinking miniature tubing and insulators.

## Important Safety Instructions

### Read These Instructions

Hidden areas such as behind walls, ceilings, floors, soffit boards and other panels may contain flammable materials that could be ignited by the heat gun when working in these locations. The ignition of these materials may not be readily apparent and could result in property damage and injury to persons.

When working in these locations, keep the heat gun moving in a back-and-forth motion. Linger or pausing in one spot could ignite the panel or the material behind it.

**WARNING:** Extreme care should be taken when stripping paint. The peelings, residue and vapors of paint may contain lead, which is poisonous. Any pre-1977 paint may contain lead and paint applied to homes prior to 1950 is likely to contain lead. Once deposited on surfaces, hand to mouth contact can result in the ingestion of lead. Exposure to even low levels of lead can cause irreversible brain and nervous system damage; young and unborn children are particularly vulnerable.

Before beginning any paint removal process you should determine whether the paint you are removing contains lead. This can be done by your local health department or by a professional who uses a paint analyzer to check the lead content of the paint to be removed.

**Lead based paint should only be removed by a professional and should not be removed using a heat gun.**

### Persons removing paint should follow these guidelines:

1. Move the work piece outdoors. If this is not possible, keep the work area well ventilated. Open the window and put an exhaust fan in one of them. Be sure the fan is moving the air from inside to outside.
2. Remove or cover any carpets, rugs, furniture, clothing, cooking utensils and air ducts.
3. Place drop cloths in the work area to catch any paint chips or peelings. Wear protective clothing such as extra work shirts, overalls and hats.
4. Work in one room at a time. Furnishings should be removed or placed in the center of the room and covered. Work areas should be sealed off from the rest of the dwelling by sealing doorways with drop cloths.
5. Children, pregnant or potentially pregnant women and nursing mothers should not be present in the work area until the work is done and all clean up is complete.
6. Wear a dust respirator mask or a dual filter (dust and fume) respirator mask which has been approved by the Occupational Safety and Health Administration (OSHA), the National Institute of Safety and Health (NIOSH), or the United States Bureau of Mines. These masks and replaceable filters are readily available at major hardware stores. Be sure the mask fits. Beards and facial hair may keep masks from sealing properly. Change filters often.

### Disposable paper masks are not adequate.

7. Use caution when operating the heat gun. Keep the heat gun moving, as excessive heat will generate fumes which can be inhaled by the operator.
8. Keep food and drink out of the work area. Wash hands, arms and face and rinse mouth before eating or drinking. Do not smoke or chew gum or tobacco in the work area.
9. Clean up all removed paint and dust by wet mopping the floors. Use a wet cloth to clean all walls, sills and any other surface where paint or dust is clinging. **Do not sweep, dry dust or vacuum.** Use a high phosphate detergent or trisodium phosphate (TSP) to wash and mop areas.
10. At the end of each work session put the paint chips and debris in a double plastic bag, close it with tape or twist ties, and dispose of properly.
11. Remove protective clothing and work shoes in the work area to avoid carrying dust into the rest of the dwelling. Wash work clothes separately. Wipe shoes off with a wet rag that is then washed with the work clothes. Wash hair and body thoroughly with soap and water.

## II. Disassembly

- a. Insert diagonal pliers under head of ferrule drive screw (1) and remove.
- b. Slide ferrule (25) forward to remove.
- c. Open wire hanger (7) and remove.
- d. Remove screws (18) and (23) and screw and nut (8).
- e. Lift left housing (12) to expose inner assembly.



## III. Assembly

- a. Position cord protector (19) as shown.
- b. Check wiring for shorts and grounds.
- c. Position left housing (12), aligning screw holes.
- d. Replace screws (18) and (23) and screw and nut (8).
- e. Replace switch (21) by snapping into place. Make sure it is well-seated.
- f. Replace ferrule (25), aligning screw hole and press in drive screw (1).
- g. Close wire hanger (7) into holes of housing assembly (9).

## IV. Cone and Insulator Assembly

- a. Disassemble per Section II.
- b. Cut off wire nut (15).
- c. Remove scroll and motor assembly (10). Remove screw (13) and lift scroll and motor assembly (10) off right housing (9).
- d. Remove cone and mica insulator assembly (2). Squeeze wide end of cone (2) to (top and bottom) to release from tabs (3) on scroll assembly, remove tape strips to release cone.
- e. Remove mica insulator (24) from heating element with diode assembly (4). Replace with new mica insulator packaged in replacement cone and insulator assembly.
- f. Replace cone (2) by snapping cone over tabs (3) on barrel end of scroll, positioning green lead of cone (2) between cone and right housing (9). For heat guns without tabs (3) on motor and scroll assembly, place aluminum tape strips provided across junction of motor and scroll assembly and cone to secure cone.
- g. Position ground wire (14) (green; yellow-green, 220 models) from cone under switch (21)
- h. Strip end of green lead of cordset (20) and twist green leads together and screw on wire nut (15).
- i. Reassemble per **Section III**.

## V. Heating Element With Diode Assembly

- a. Disassemble per **Section II**.
- b. Remove screw (13) and lift motor and scroll assembly (10) off right housing (9).
- c. Squeeze wide end of cone (2) (top and bottom) to release from tabs (3) on scroll (or remove tape strips); then remove cone.
- d. Remove left scroll half (11).
- e. Desolder joints at points (5) and (6). **CAUTION: Do not overheat solder joints or adjacent plastic will melt.**
- f. Remove red wire leads from terminals on switch (21).
- g. Lift heating element with diode assembly (4) away from housing (9).
- h. Slip new heating element with diode assembly into motor and scroll assembly (10) and resolder bare leads at solder joints (5) and (6) as shown. See **CAUTION** note, **Section V, Step 5**.
- i. Snap left scroll half (11) over motor and scroll assembly (10) and snap cone (2) over tabs (3) on barrel end of scroll (or replace tape strips), positioning green lead of cone between cone (2) and right housing (9). Replace scroll and cone in original position as shown, making sure no leads are underneath motor and scroll assembly (10). Replace screw (13) and tighten.
- j. Attach red leads with connectors to switch (21) as shown.
- k. Connect red lead from thermal cutoff (22) to remaining lead from cordset. Twist bare leads together and screw on plastic wire nut (16).
- l. Reassemble per **Section III**.

## VI. Motor and Scroll Assembly

- For removal of motor and scroll assembly (10) follow steps 1 through 5 in **Section II**, and steps 1 through 5 in **Section V**.
- Remove motor and scroll assembly (10) without disconnecting heating element with diode assembly (4).
- Insert replacement motor and scroll assembly.
- Resolder bare leads at solder joints (5) and (6). See **CAUTION** note, **Section V, step 5**.
- Dress Wires (See Illustration)
- Join left scroll half (11) with motor and scroll assembly (10) **per step 9 in Section V**.
- Reassembly per **Section III**.

## VII. Three Wire Cordset Assembly

- Disassemble per **Section II**.
- Remove center lead connector form center terminal on Switch (21).
- Cut and remove plastic wire nut (15) on green

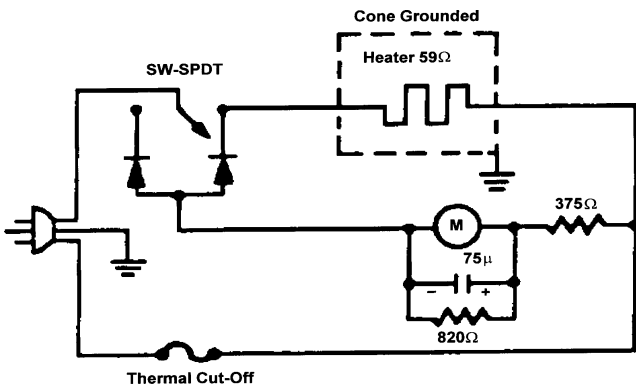

WIRING SCHEMATIC FOR MODELS 6966C, 6966K & 6966S

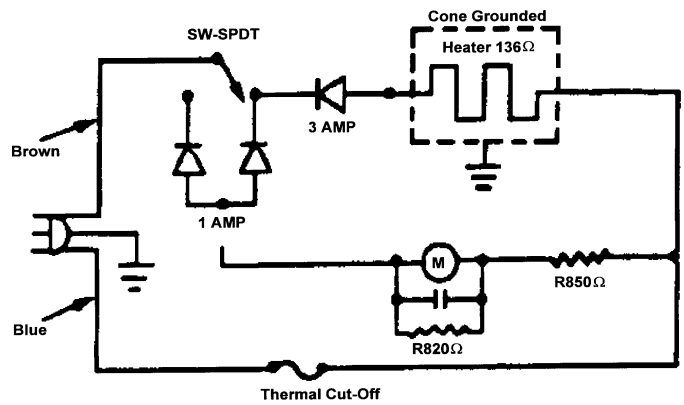

WIRING SCHEMATIC FOR MODELS 6966G & 6966R

### I. Replacement Part Numbers

120v	240v	Description	120v	240v	Description
168	168	Cone and Insulator	187K	—	3-Wire Cord Assembly for Model 6966K
182	182G	Heating Element with Diode Assembly	188	188	Hot-Off-Cold Switch
183K	—	Heating Element with Diode Assembly for Model 6966K	189	189	Heat Gun Case
183	183G	Motor and Scroll Assembly	6956	6956	Shrink Tubing Reflector
185	185	Ferrule	6957	6957	Shrink Tubing Reflector
187	187G	3-Wire Cord Assembly	6958	6958	Reducing Baffle
			6964	6964	Precision Reflector

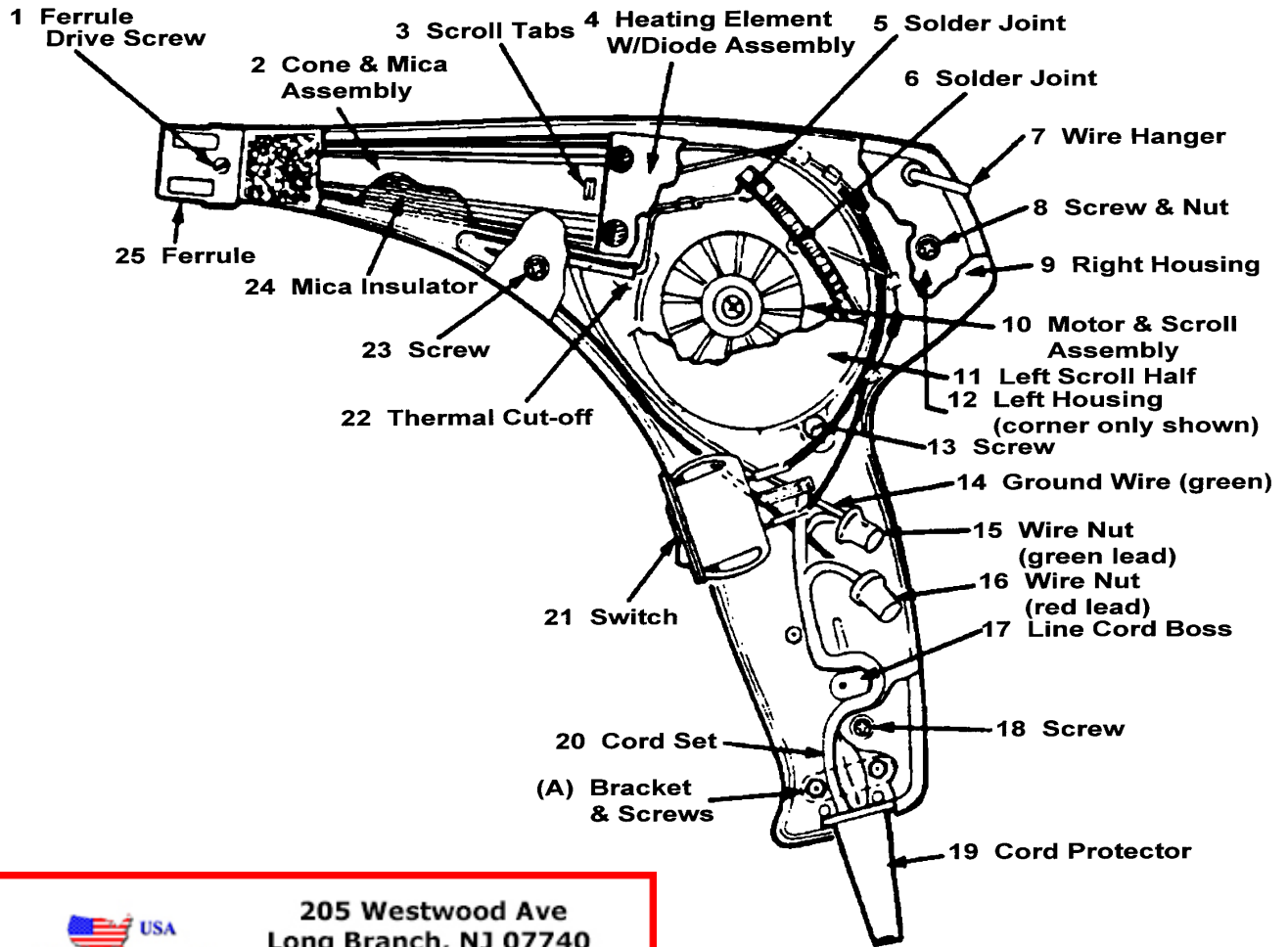

**T** USA  
**Equipment**  
**.NET**

205 Westwood Ave  
 Long Branch, NJ 07740  
 1-877-742-TEST (8378)  
 Fax: (732) 222-7088  
 salesteam@Tequipment.NET

**Weller Model 6966 Heat Gun  
 One Year Limited Warranty**

Your Weller Heat Gun was carefully tested and inspected before it was shipped from the factory. We warrant this product to be free from defects in materials and workmanship under normal use and service for one year from the date of purchase. In the event of a defect in materials or workmanship, we will either repair or replace without charge, at our option, any part which in our judgment shows evidence of such defect within one year of purchase.

This warranty does not apply if the Heat Gun has been misused, abused, altered, tampered with, or used on voltage other than specified on the nameplate. At the end of the warranty period, Weller shall be under no further obligation expressed or implied.

This warranty gives you specific rights, and you may also have other rights which may vary from state to state.

For repair services, return your Heat Gun prepaid, with a note describing the problem, to Cooper Hand Tools Division, Apex Plant, 1000 Lufkin Road, Apex, NC 27539, ATTN: Repair Department.