

---

# INSTALLATION INSTRUCTIONS

---

## WMA-300 Single Stud Wall Arm

The WMA-300 Single Stud Wall Arm can be used to wall mount RPA, UPC or LCDA series ceiling mounts.

The WMA-300 also provides a mounting solution for TV/Monitor mounts. The WMA-300 has a maximum weight capacity of 150 lbs (68.0 kg).

The wall arm on the WMA-300 is 18.25" in length from the wall mount.

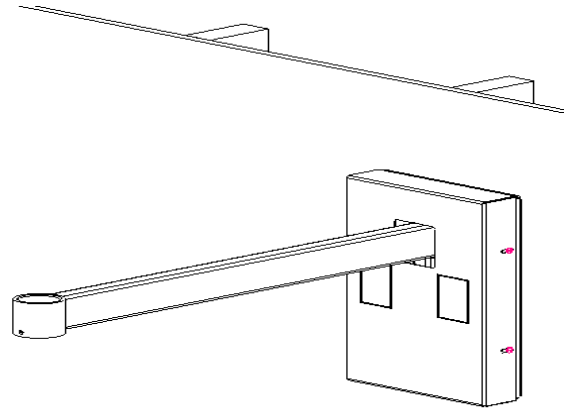

WMA-300 Single Stud Wall Arm

# Touchboards

205 Westwood Ave, Long Branch, NJ 07740  
Phone: 866-94 BOARDS (26273) / (732)-222-1511  
Fax: (732)-222-7088 | E-mail: sales@touchboards.com

### BEFORE YOU BEGIN

- **CAUTION:** To prevent damage to your equipment, which could affect or void the Factory warranty, thoroughly study all instructions and illustrations before you begin to install the WMA-300. Pay particular attention to the Warnings and Cautions in this document.
- If you have any questions about this installation, contact Chief Manufacturing at 1-800-582-6480 or 952-582-6480.



**CHIEF MANUFACTURING INC.**  
1-800-582-6480 952-894-6280 FAX 952-894-6918  
8401 EAGLE CREEK PARKWAY, STE. 700  
SAVAGE, MINNESOTA 55378 USA

8809-000014 (Rev. B)  
2004 Chief Manufacturing  
[www.chiefmfg.com](http://www.chiefmfg.com)  
11/04

# WMA-300 – SPECIFICATIONS

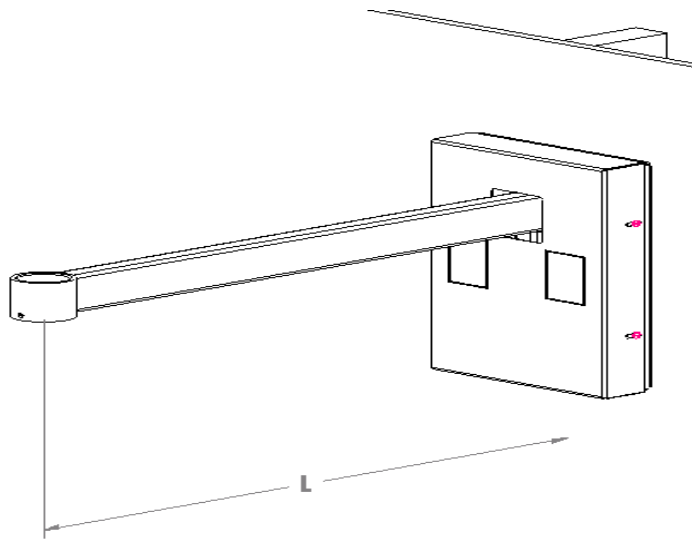

**(L) Length**

**Table 1. WMA-300 Specifications**

Model	L-Length (fixed)	Max Support Weight	Wall Mount Description
WMA-300*	18.25"	150 lbs (68.0 kg)	Wood Stud Installation

**NOTES**

1. \*Metal stud mounting is not recommended.
2. For concrete or brick installations, use CMA-380.

**! IMPORTANT WARNINGS and CAUTIONS!**

<b>WARNING</b>	<b>A WARNING alerts you to the possibility of serious injury or death if you do not follow the instructions.</b>
<b>CAUTION</b>	<b>A CAUTION alerts you to the possibility of damage or destruction of equipment if you do not follow the corresponding instructions.</b>
<b>WARNING</b>	<b>Improper installation can result in serious personal injury! Make sure that the mounting surface can support a redundant weight factor <i>five times</i> the total weight of the equipment: if not, reinforce the mounting surface structural members before installing the mount.</b>
<b>WARNING</b>	<b>Be aware of the potential for personal injury or damage to the equipment if it is not adequately mounted.</b>
<b>WARNING</b>	<b>The installer is responsible for verifying that the mounting surface to which the WMA-300 is anchored will safely support the combined load of all attached components or other equipment.</b>
<b>WARNING</b>	<b>The combined weight of the TV/monitor and all attached components and equipment placed on a Chief Wall Arm must not exceed the maximum support weight specified in Table 1 (see page 2).</b>
<b>WARNING</b>	<b>Watch for pinch points. Do not put your fingers between movable parts.</b>
<b>CAUTION</b>	<b>Check the unit for shipping damage before you begin the installation.</b>

**CONTENTS**

WMA-300 – SPECIFICATIONS .....2  
 CONTENTS.....3  
 INSPECT THE UNIT BEFORE INSTALLING .....3  
 PARTS .....4  
 TOOLS REQUIRED FOR INSTALLATION .....5  
 INSTRUCTIONS .....5  
     Installing Wall Arm.....5  
     Attaching Front Cover.....6  
     Connecting NPT Pipe or Nipple to Wall Arm.....6

**INSPECT THE UNIT BEFORE INSTALLING**

Unpack the carton. Carefully inspect the parts for shipping damage. Verify contents listed in Table 2. If you are missing any of the listed parts, contact Customer Service at: 1-800/582-6480.300.

**Table 2. Shipping Contents**

<b>ITEM</b>	<b>DESCRIPTION</b>	<b>QTY</b>
10	Wall Arm	1
20	Front Cover	1
30	5/16 X 2.5” Lag Bolt	2
40	5/16 Flat Washer	2
50	M4 X 8mm Phillips Head Cap Screw	4
60	M6 X 6mm Set Screw	1
70	M3 Allen Key	1

# PARTS

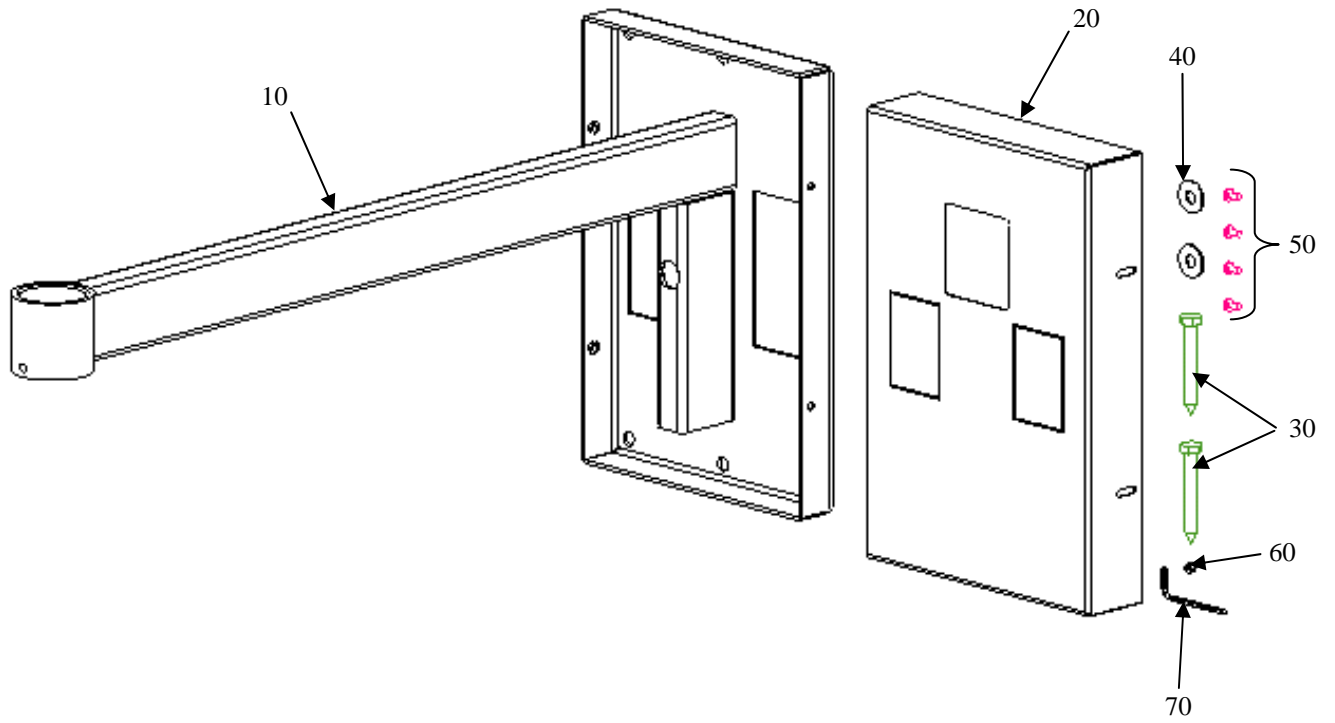

Figure 1. WMA-300 Parts

## TOOLS REQUIRED FOR INSTALLATION

The tools required for installation are as follows:

- Electric drill and bit set
- Stud sensor (mechanical or electronic)
- ½" box-end wrench or ratchet with ½" socket
- 13mm box-end wrench or ratchet with 13mm socket
- Level

**NOTE:** Other tools may be required depending on your method of installation.

## INSTRUCTIONS

### Step 1

#### Installing Wall Arm

1. Locate the wall arm (10), two lag bolts (30) and two flat washers (40). See Figure 2.

#### WARNING

It is the installer's responsibility to verify that the structure to which the mount is anchored will safely support *five times* the combined load of all attached components and equipment.

2. Determine a suitable mounting location. Keep in mind that you will be mounting the wall arm (10) to a wood stud, on center.
3. Using a stud sensor, locate the wood stud where you will mount the wall arm (10).
4. Holding the wall arm (10) against the wall, use a pencil, awl, or small nail to mark the mounting holes where two pilot holes will be drilled into the center of the wood stud. Make sure that the mounting holes are centered.
5. Using a 15/64" drill bit, drill two pilot holes for anchoring the wall arm (10).
6. Using two 5/16" lag bolts (30) and two 5/16" flat washers (40), install the wall arm (10) on the wall.

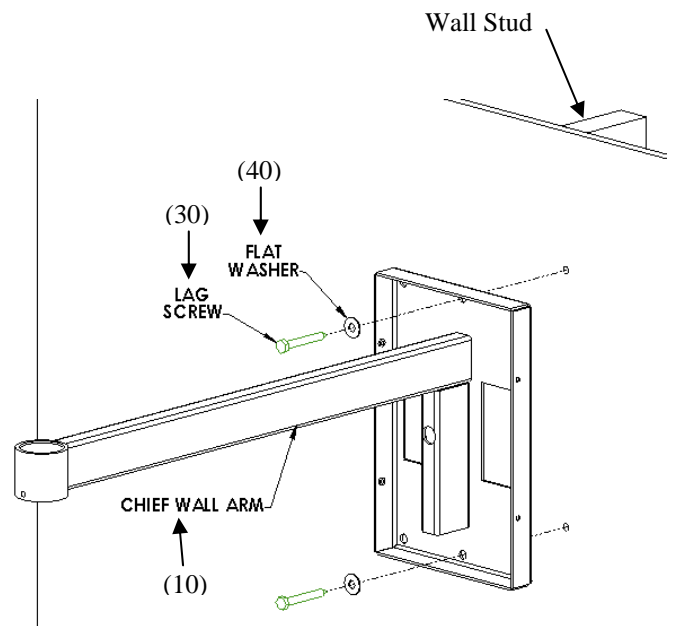

**Figure 2. Install Wall Arm**

## STEP 2

### Attaching Front Cover

1. Locate front cover (20) and four M4 x 8mm Phillips head cap screws (50).

#### NOTES

- The front cover may be partially removed and reinstalled to conceal power/audio/video cables after the TV/Mount is installed.
  - You may remove one or both knockouts on cover to assist routing to wall through cover.
2. Install the front cover (20) using four M4 8mm Phillips head cap screws (50). See Figure 3.

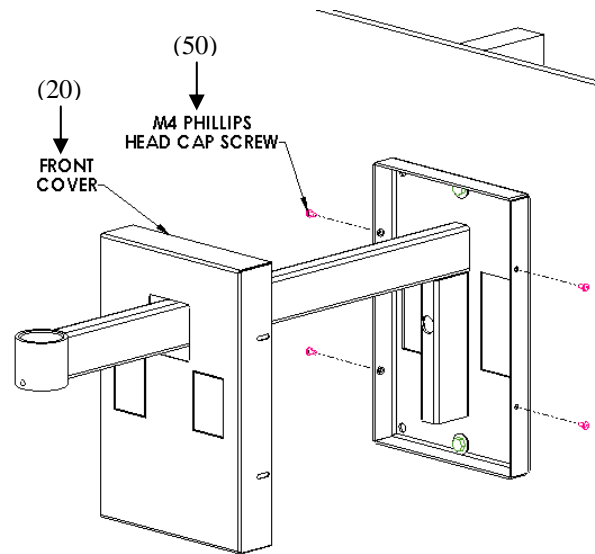

Figure 3. Attach Front Cover

## STEP 3

### Connecting NPT Pipe or Nipple to Wall Arm

1. Locate M6 x 6mm set screw (60) and 1-1/2" NPT pipe or nipple (supplied with TV Mount or purchased separately).
2. Connect the 1-1/2" NPT pipe or nipple (supplied with TV Mount or purchased separately) to the wall arm (10). See Figure 4.
3. Using the M3 Allen key (70), install the M6 x 6mm set screw (60). Tighten the set screw.

#### WARNING

Make sure to tighten the M6 x 6mm set screw (60) to prevent equipment damage or personal injury.

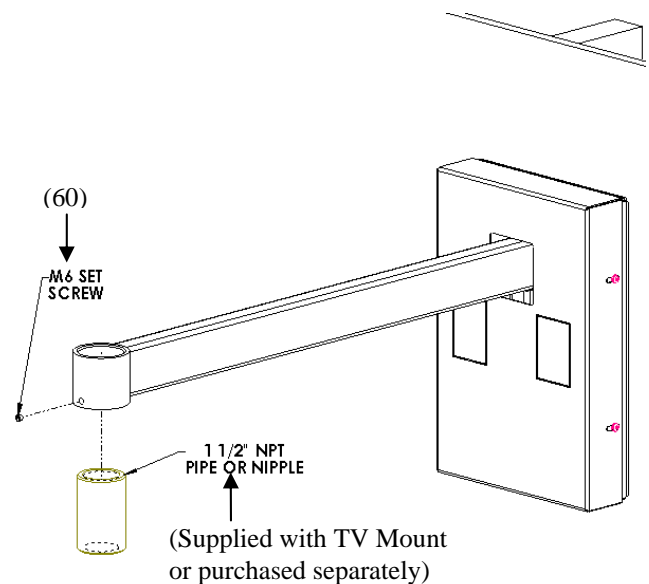

Figure 4. Connect NPT Pipe or Nipple to Wall Arm



