

Specifications

SUV-Cam II

SUV-Cam PROFESSIONAL

Camera head	main unit	Water proofing	IPX8	
		Total length	80cm	
			150cm	
			-	300cm 500cm
		Mass	80cm=Approx.115g	
	150cm=Approx.150g			
	Lens	Dimension	diameter ϕ 20mm length ϕ 84.8mm	
		Focal length	3.8mm	
		F number	2.0	
		Horizontal field angle	53.4 °	
		Vertical field angle	40.0 °	
		Focus adjustment	Manual	
		Shooting range	0.5m to (factory setting)	
	Camera	Lens fixing	Lens stopper (Rubber spacer)	
		Image pickup element	1/4 CCD	
Total picture element		470,000 pixels		
Effective number of pixels		440,000 pixels		
min. object brightness		2 lx		
White balance		Auto/Fixed		
Electronic shutter		1/50 to 1/100,000 sec		
Resolution		Horizontal :480TV Vertical :420TV		
S/N ratio		48dB or more		
Recorder	main unit	LCD monitor	2.2 full color TFT LCD (QVGA)	
		Built-in microphone	Monaural microphone (Built-in)	
		Recording medium	SD card (Compatible with FAT12 and FAT16)	
			SDHC card (Compatible with FAT32)	
		File format	asf.	
		Moving image compressed format	Compliant with MPEG4	
		Audio compression format	Compliant with G.726	
		Vide output	NTSC/PAL (switches by the setting item.)	
		Audio input	Input impedance 2.2k Ω or more	
		Audio output	38mW + 38mW (Audio: Monaural) Load impedance 16 Ω	
		USB	USB 2.0	
		Mass	Approx. 130g (when battery is installed)	
	Dimension	56mm (Horizontal) x 102mm (Vertical) x 30mm (width) (Exclude the projection part)		
	Terminal	Earphone/AV OUT	3.5 minijack (stereo)	
		External microphone	3.5 minijack (monaural) Plug-in power type	
DC IN		Dedicated jack		
Power supply part	main	Power supply	DC 3.7V(when the battery is used) DC 5.0V(when the AC adapter is used)	/
		Power consumption	2.8W(when the battery is used) 4.5W(when the AC adapter is used)	/
	Battery pack	Type	Lithium-ion battery (desorption type)	
		Nominal voltage	3.7V	
		Rating capacity	1660mAh	
		Mass	Approx.43g	
		Dimension	39mm (Horizontal) x 78mm (Vertical) x 9mm(width)	
	When battery detached	Power supply through AC adapter to recorder		
	AC adapter	Power supply	AC 100 - 250V 50 - 60Hz	
		Power consumption	DC 5.0V 2.0A	
		Mass	Approx.115g(Exclude the power code)	
		Dimension	53mm (Horizontal) x 76mm (Vertical) x 26mm (width)	
Use environment	Operating temperature	0 ° C to 40 ° C(Camera Head -10 ° C to 50 ° C)		
	Allowable relative humidity	10% to 80%		

Mass

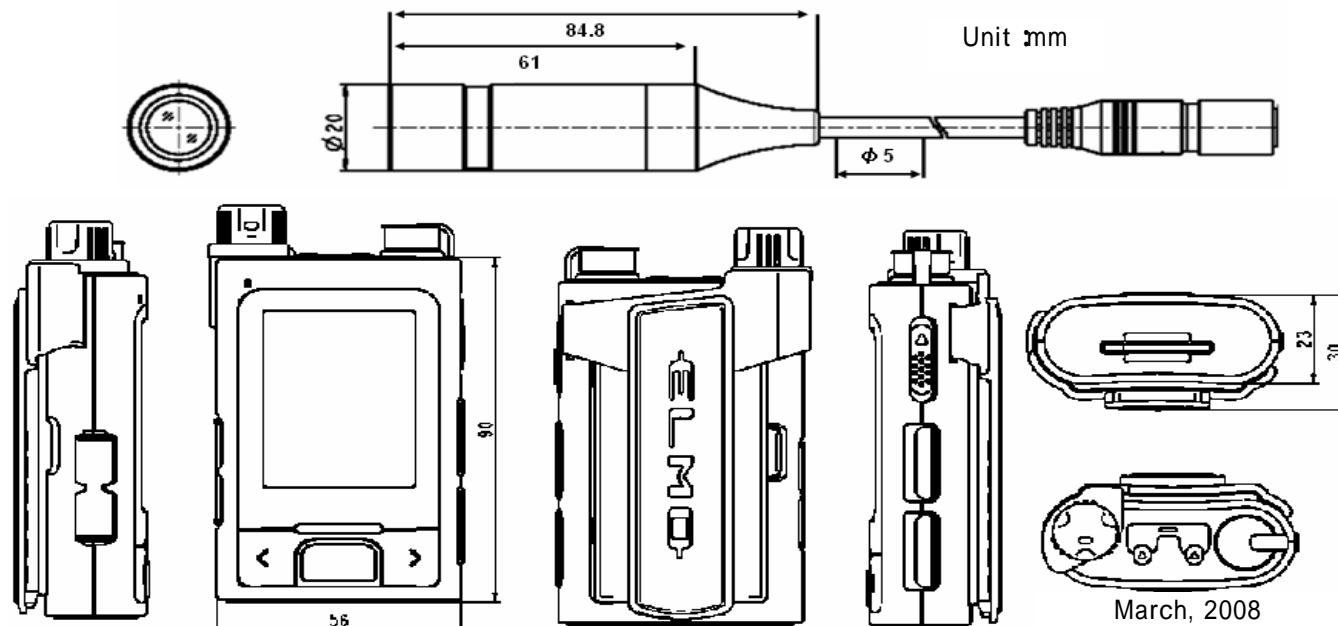

TOUCHBOARDS
 1-866-942-6273 .COM

205 Westwood Ave, Long Branch, NJ 07740
Phone: 866-94 BOARDS (26273) / (732)-222-1511
Fax: (732)-222-7088 | E-mail: sales@touchboards.com