

## TT-02 Specifications

Model		TT-02	
Camera	Image pick-up device	1/3" progressive scan CCD, 850,000 pixels	
	Effective pixels	1,024 (H) x 768 (V)	
	Frame rate	20 frames/sec.	
	Resolution	600 (H) x 600 (V) TV lines	
Optics	Zoom	Powered (with double speed function), 5.3X optical	
	Lens	F2.0 to 4.4, f=4.0 to 21.2 mm	
	Shooting area	Max. 16 7/8" x 12 1/2" (426 x 317 mm) Min. 3 5/8" x 2 3/4" (93 x 70 mm) for 17-inch document	
	Focus	Auto/Manual (powered)	
	Auto brightness control	Auto/Manual (powered)	
Functions	White balance	Auto/Push set/Manual	
	Negative/positive conversion	Provided	
	Color/B&W selection	Provided	
	Gamma adjustment	Provided	
	Pause mode	Provided	
	Digital zoom	Provided (8X)	
	Image rotation	Provided (0°, 180°)	
	OSD (on-screen display)	Provided	
	Text mode	Provided	
	State presetting	Up to 4 user settings	
	Free-stop arm	Provided	
	Microscope viewing mode	Provided	
	Input/output	Internal selection	Int./RGB
Analog RGB output		XGA (1,024 x 768 @60 Hz)	
Video output		Composite	
RGB input		Provided	
Others	Accessories	AC adapter, RGB cable, instruction manual, removable stage, magnet sheet, anti-glare sheet (A5 size)	
	Dimensions (W x D x H)	Set up	13 1/2" x 14 1/2" x 16 1/4" (343 x 368 x 411 mm)
		Folded	7 3/4" x 14 1/2" x 17 1/2" (195 x 368 x 444 mm)
	Weight	6.6 lbs (3.0 kg)	
	Power consumption	9W	
Power source	DC 12V (AC adapter)		

H: horizontal, V: vertical

Design and specifications are subject to change without prior notice.

**ELMO** is a trademark of ELMO COMPANY, LIMITED.

Other brand names and product names may be trademarks or registered trademarks of their respective owners. The images on this brochure are simulated.

### ELMO's Helping to Provide a Greener Future for Our Children

This ELMO product complies with all RoHS directives (Restriction Of the use of certain Hazardous Substances in electronic equipment). This compliance helps to ensure a healthier and greener environment for all our children. ([www.rohsdirective.com](http://www.rohsdirective.com) for more details)

**ELMO**  
FOCUS ON THE FUTURE

Additional technical information is available from any of the following subsidiary companies:

#### ELMO USA Corp.

1478 Old Country Road, Plainview, NY 11803-5034, U.S.A.  
Tel. 516-501-1400 Fax. 516-501-0429  
E-mail: [elmo@elmousa.com](mailto:elmo@elmousa.com)  
Web: <http://www.elmousa.com>

## Profile

All dimensions in inches (mm)

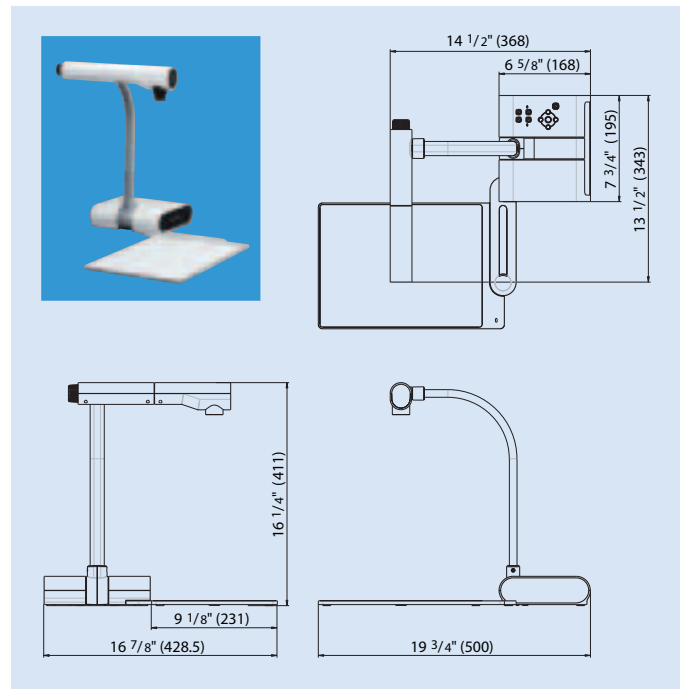

## Rear Panel



ELMO CO., LTD. (Head Office and Factory)'s QMS/EMS has been registered to ISO 9001:2000 & ISO 14001:2004.