

We make finding the  
Writeboard easy

**TOUCHBOARDS**

1-866-942-6273 .COM

205 Westwood Ave, Long Branch, NJ 07740

Phone: 866-94 BOARDS (26273) / (732)-222-1511

Fax: (732)-222-7088 | E-mail: sales@touchboards.com



# BX-AL133 Anamorphic Lens



# User's Manual



## Safety

1. Read and understand instructions and heed warnings before beginning installation.
2. Mount rail securely. The lens is heavy, and requires a secure and stable surface. Fasteners in sheetrock alone are not safe. Reciprocal lens motion can and will work them loose. Use a board, plate, or projector mount fixed to ceiling joists or studs.
3. Anticipate unexpected lens motion. A malfunction can cause the lens to move unexpectedly. Disconnect the power when installing, working on or repositioning the lens. While on a ladder, do not stand in the direct path of the lens in case of unexpected or accidental movement.
4. Do not install the lens in a wet or moist environment, or where the mechanism will be exposed to extreme or external weather conditions. The lens is for indoor use only.
5. Never pour any liquid or push any object into the enclosure.
6. Do not install in direct path of heater vents or projector exhaust ports. Do not block any of the vents or holes in the enclosure.
7. The power adaptor is intended for 100- 220 volt, 50-60 cycle AC power only.
8. Do not subject power cord to conditions which will wear through or cut the insulation. Avoid excessive tension or chafing of the cord.
9. Do not service the motor drive or electronics. There are no user serviceable parts. Contact your dealer or send to a factory approved facility. Opening the case will void the warranty.
10. Exercise extreme caution when working on a ladder. Do not work directly above another person, particularly a child. Plan all work carefully. Accidentally dropping a drill, hammer, or the lens assembly can cause serious bodily injury.
11. Pushing or forcing the sled by hand may damage the circuit board. Should it be necessary to move the sled by hand, make sure it is done slowly and lightly.
12. The Optoma motorized sled will ramp up and down at the beginning and end of the traversal to minimize swaying forces at the mount. As the motor accelerates and brakes, there is a minimal change in the sound.



This device complies with part 15 of the FCC rules. Operation is subject to the following two conditions: (1) This device may not cause harmful interference, and (2) this device must accept any interference received, including interference that may cause undesired operation.

September 2005 Edition

## Introduction

Thank you for purchasing the Optoma BX-AL133 anamorphic lens. The lens and motorized sled is outfitted with a custom mechanism designed exclusively for use in a home theater environment.

No oil or liquid based lubricants are used to assure the maximum cleanliness of optical components. Both lens and drive will provide years of maintenance free service. The Optoma system is built and tested in the USA with the strictest quality standards and certifications.

### Features and benefits:

- Easy, straight forward installation and operation
- Machined, high-grade, anodized aluminum components
- Repeatable precision positioning system
- Flexible mounting options for either table top or ceiling mount
- Speed selector for high or low speed operation
- Configurable “lens in” position
- Extra external IR sensor for remote mounting (if needed)
- Input 12V jack for automatic lens trigger
- Output 12V jack for screen masking trigger
- Non-mechanical long life optical stop sensors
- Dry operating precision linear bearings
- Heavy-duty, high-precision NEMA 23 stepper motor
- Custom built, low noise stepper drive circuitry and firmware
- Endurance tested to more than 250,000 traversals
- 8-button long-range (up to 50 feet) remote control with discrete functions
- Backlit logo with on/off lighting control
- Reversible logo plates
- Built and tested in the USA
- FCC, CE and UL certified

# Getting to Know Your System

## Motorized Sled

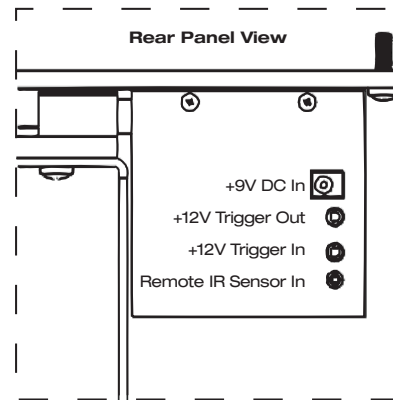
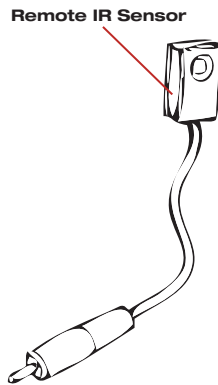
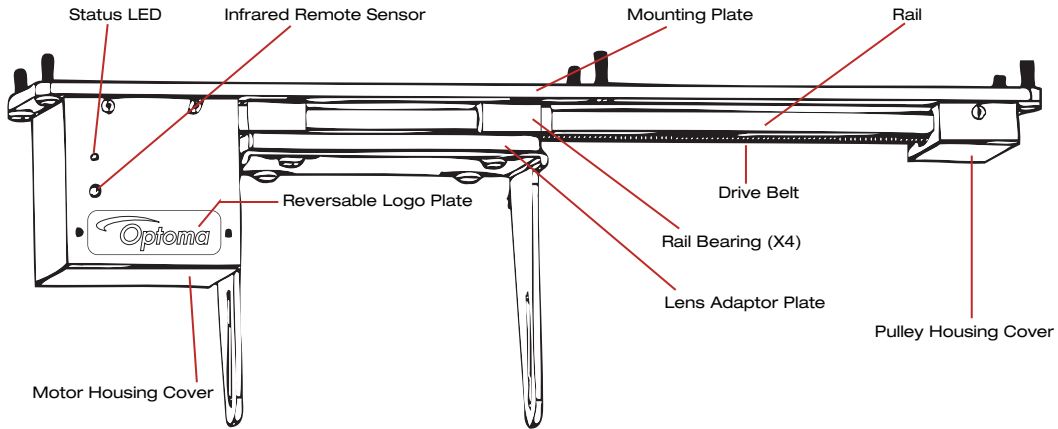

## 8-Button Remote Control

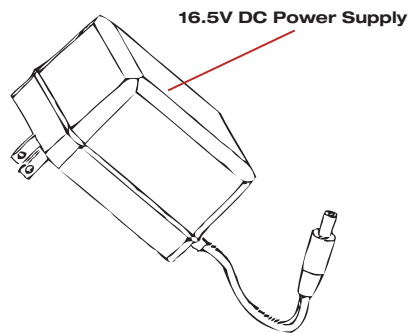
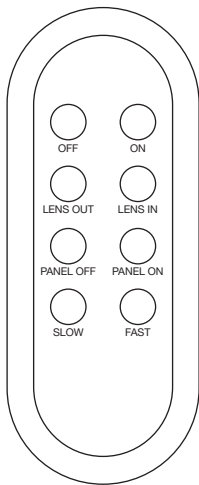

## Plan Your Installation

The lens assembly may be mounted in one of two ways:

1. To the ceiling or projector mount above the projector
2. To a shelf or table below the projector



*When attaching the motor assembly to the ceiling, use a board, plate or lens-enabled projector mount that is attached to ceiling joists or studs. Sheetrock embedded fasteners can and will become loose with repeated lens movement, causing the mechanism to fall, resulting in possible severe injury.*

### Planning for Projector Exhaust

Some projectors have hot air exhaust ports that discharge from the front. Avoid situations where the lens or housing will block or obstruct the warm air flow out of the projector, as damage to the bulb and/or the lens may result. You can mount the sled either to the left or right of the lens. During setup, you can easily configure the “lens-in” position to be on the motor housing or pulley housing side of the sled. (See Setup).

### Changing Orientation of Logo Plate (Optional)

The lens sled is configured for ceiling mounted operation as shipped. As such, the logo reads right side up with the mounting bar on top. If you are using the sled in a table or shelf mounted configuration, you will want to turn the logo around so that it is right side up with the mounting bar below the projector.

To reverse the logo, remove the 4 screws securing the motor housing cover. Lightly slide the sheet metal cover and lift it off. Once removed, you can easily access the logo plate. Remove the two small screws securing the logo plate, turn the plate around, and re-install the screws. Install the motor cover housing back on the sled with the original screws.

The logo backlight may be turned off using the remote control. An alternative to reversing the logo plate is to simply turn off the back light to make the logo less conspicuous.

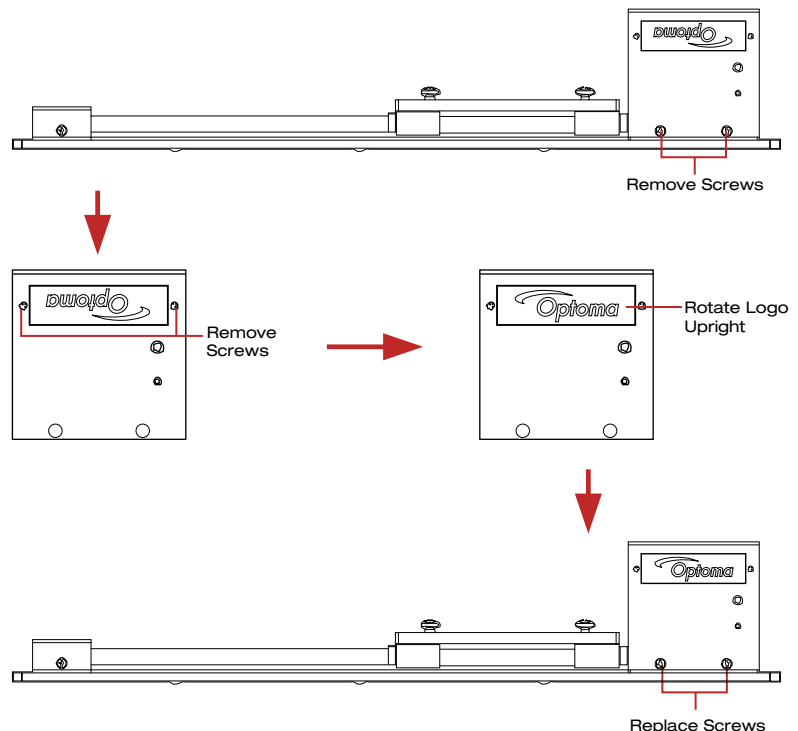

## Mounting Sled to Shelf or Ceiling

When installing the motorized sled, make sure that you first mark screw locations using only the sled—without the lens and/or the lens bracket in place.



*Do not rely on fasteners embedded in sheetrock alone. Reciprocal lens movement can and will work them loose and cause the mechanism to fall. Mount the sled on a plate, board, or lens-enabled projector mount affixed to ceiling joists for safety.*

Once the sled is secure, attach the bracket to the lens adaptor plate. Then, only after properly aligning and positioning the bracket, power up the sled and check the alignment again. Finally, attach and adjust the lens to its correct angle and vertical position.

**Follow this procedure:**

### 1. Line up the center line of lens

There are score marks on the back of the mounting bar that correspond to the center of the BX-AL133 expansion lens. Before starting, the projector must be correctly focused with the zoom and iris set in their viewing positions. This will assure that the front of the lens is positioned correctly. Hold the motorized sled up to the projector and determine if the LENS IN position will be on the motor housing (logo side) or the pulley housing (smaller box) side. This will determine the score mark you will use (see below).

Measure 2-1/8 inches from the front of the projector lens, and lightly draw a line parallel to the front of the lens. Mark the center line of the projector lens along this parallel line. Line up the back of the mounting bar to the parallel line just marked. Align the center of the projector lens mark with the correct score line on the mounting bar, and mark the six drill hole locations using the mounting bar itself as a template. Drill out the holes for the fasteners.

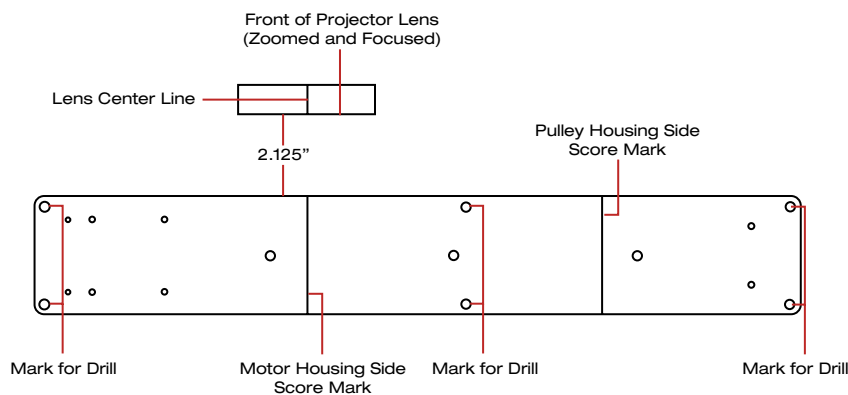

## 2. Securing the mounting plate

Because the mechanism and lens are heavy, make sure the mounting fasteners and surface are extremely secure. Remember that the sled motor will be starting and stopping a heavy weight thousands of times through normal use. Ceiling mounted lenses require a secure surface.



*Sheetrock anchors alone are insufficient. Secure the mounting bar to a plate, painted board, or lens-enabled projector mount that is securely affixed to the studs or ceiling joists.*

Use of a commercial mounting system enabled for anamorphic lenses is highly recommended. Use all six screw holes, and tighten fasteners securely. Vibration from the motor and reciprocal lens movement will loosen any fasteners that are not absolutely tight and secure.



*Do not attach the lens or power up the sled yet! Adjustment and alignment are much easier at this point without the lens.*

## 3. Attaching the lens bracket to the adaptor plate

Remove the bracket mounting screws from the inside holes in the adaptor plate and use them to attach the lens bracket supplied with the Optoma BX-AL133 anamorphic lens system. If the lens is attached to the bracket, make sure to remove the lens prior to attaching to the lens adaptor plate.

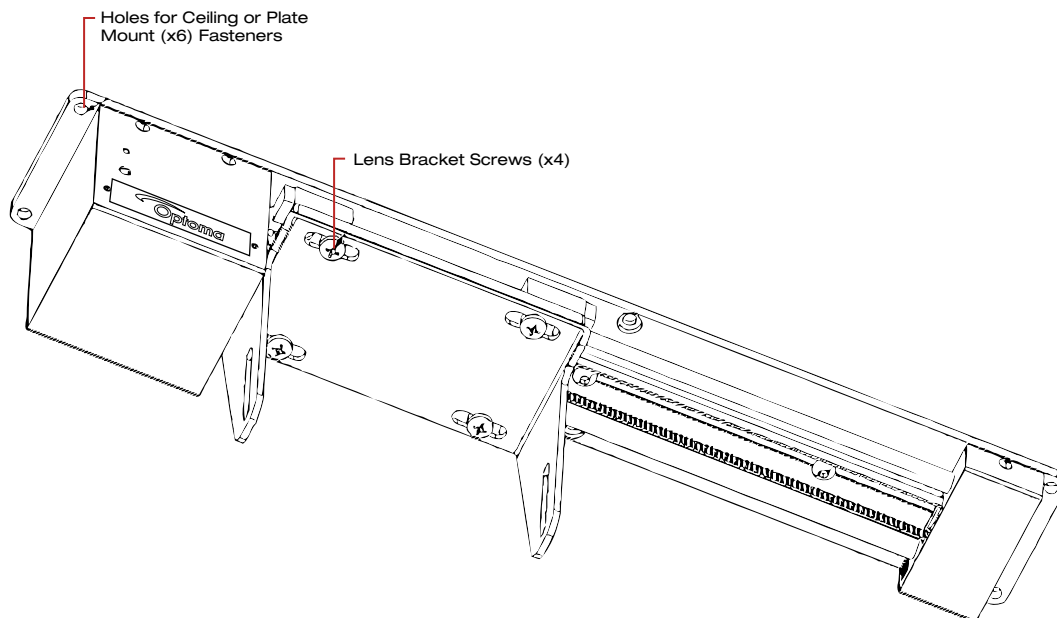

# Setup

## 1. Power up the sled and set LENS IN position

Slide the lens into the middle of the sled before powering up. Plug the power adaptor into an AC outlet, then into the back of the unit as illustrated. Using the remote, press the “lens in” button. The lens sled will slowly position itself into the factory default LENS IN position. The edge of the adaptor plate will land about a half-inch from the motor housing side of the sled. If the bracket is in front of the projector lens, proceed to the next step (Verify centering).

If the bracket is not in front of the projector lens, you will need to change the setting. Simply press the LENS OUT button on the remote, and wait for the bracket to move in front of the projector lens. Press and hold the LENS OUT button again for 5 seconds. The sled will confirm the new setting by moving the bracket away from the projector lens to the new LENS OUT location. The edge of the adaptor plate will land about a half-inch from the motor housing side of the sled. You have now re-programmed the sled. This setting will be preserved in the unit even if it is unplugged or undergoes a power failure. To change back, just repeat the above procedure.

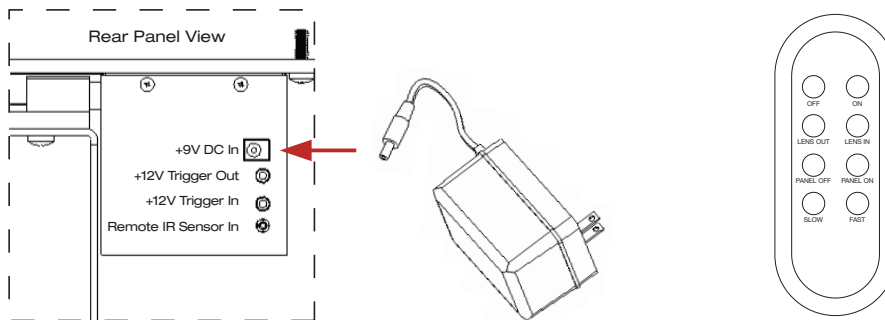

## 2. Verify centering

Press LENS IN and see where the lens stops. If needed, make small adjustments (+ or – a quarter-inch) to the lens bracket after disconnecting the power, by loosening the screws and sliding the bracket to the left or right as needed to achieve centering.

Reconnect the power and check the centering. The optical sensors will stop the edge of the lens adaptor plate approximately a half-inch from the housing on either side of the sled. You can use this gap on the motor or the pulley side for fine-tuning adjustments.

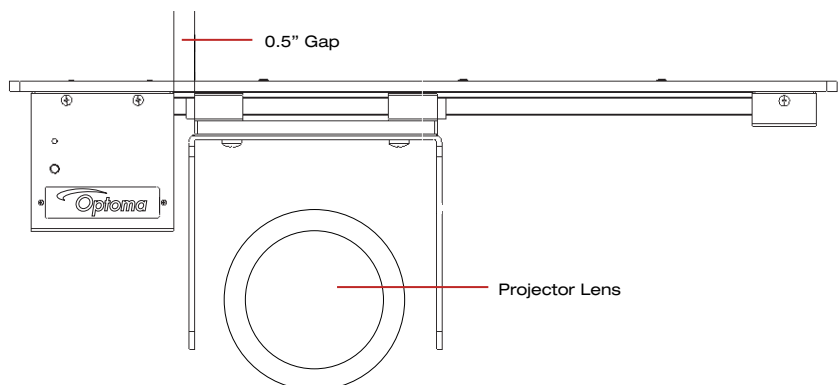



### 3. Attaching the lens to the bracket

Attach the Optoma BX-AL133 anamorphic lens to the bracket using the plastic knobs supplied with the lens. Adjust the anamorphic lens vertically for correct alignment. When the image is correct, tighten the knobs against the bracket. Using the remote, test run LENS IN and LENS OUT commands.

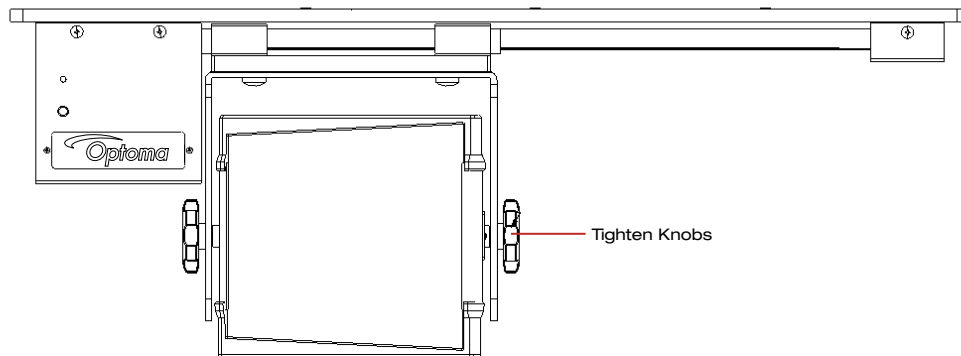

### 4. Configuring the lens speed

The lens has two operating speed modes – FAST and SLOW. Slow is the default from the factory. The slow mode reduces the inertia exerted by the lens on the mounting system by accelerating and decelerating very slowly, and by limiting the top speed of the lens as it traverses the sled.

If the sled is on a very rigid mount that is not subject to any sway, you can speed up the traversal speed by setting the lens speed to FAST. If you notice any swaying in the mounting, reset the speed to SLOW.

Some users set the speed to SLOW when used in conjunction with screen masking systems. Your speed setting will be “remembered” by the control unit even if the power is interrupted.

Congratulations, you are now ready to experience widescreen cinema from your home theater.

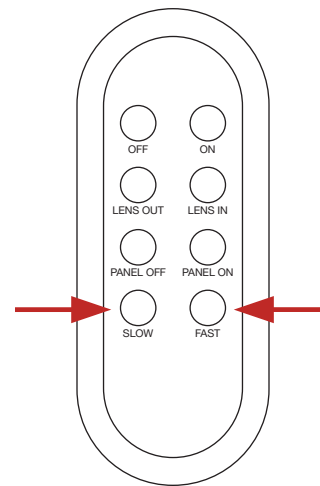

## Remote Control and Motor Operation

The LED indicator on the sled will glow when the unit is ON, and flash when any button is pressed. It will also flash when the lens is in motion. The LED will be off in standby mode.

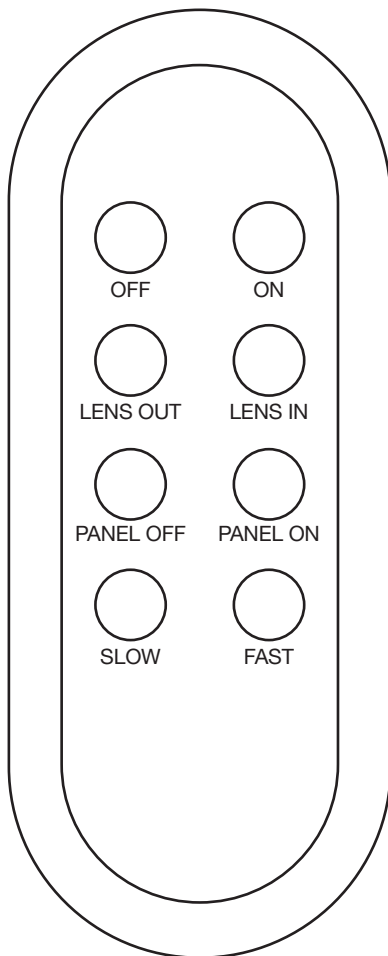

### Buttons:

**OFF** – Puts the sled in standby mode.

**ON** – Turns the sled from standby to ON.

**LENS OUT** – Commands the lens to move into the LENS OUT position.

Holding the button for several seconds re-programs the current position as the new LENS IN position. The lens sled will acknowledge the request by flashing the LED and moving the lens to the new LENS OUT position (the opposite side).

**LENS IN** – Commands the lens to move into the LENS IN position (as configured in Setup).

**PANEL OFF** – Turns the logo backlight off.

**PANEL ON** – Turns the logo backlight on.

**SLOW** – Sets the acceleration/deceleration and maximum speed for slow (low inertia) traversal.

**FAST** – Sets the acceleration/deceleration and maximum speed for rapid traversal.

## Rear Panel - Triggers and Sensors

To use the automatic lens trigger, your projector or scalar must be equipped with a lens trigger and a standard double-ended 3.5 mm (1/8 inch) male mono or stereo jack cable.

Simply plug the cable into the projector's lens trigger jack and into the sled +12V Trigger-In jack. Follow the projector or scalar instructions to configure the lens trigger.

The Trigger-In (tip positive) operates as follows:

+12V	LENS IN command
0V	LENS OUT command

*NOTE: The input trigger jack may be temporarily overridden by the remote control. When the next transition of voltage occurs (up or down), the trigger will take control once again.*

Another option allows you to use the +12V Trigger-Out jack on the rear of the device. The output jack is set to +12V whenever the sled is in the LENS OUT position.

This is typically used for triggering screen masking systems to mask the side of the screen when an HDTV (16:9) image is being projected instead of a widescreen (2.35:1) DVD movie format.

The Trigger-Out jack (tip positive) operates as follows:

0V	Lens is in the LENS IN position
+12V	Lens is in the LENS OUT position

Each sled is supplied with an optional remote IR sensor which may be used to improve reception if the sled is located where IR signals cannot be reached. It may also be used with an IR repeater system by simply taping the remote sensor to one of the IR emitters from the repeater system.

To use, simply peel off the included self-stick tape, affix to a convenient location and plug the 2.5 mm cable into the appropriate jack in the back of the unit.

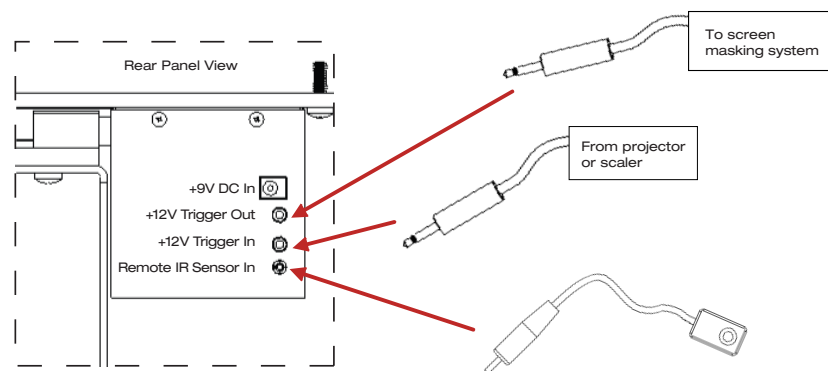

## **Cleaning and Maintenance**

The Optoma BX-AL133 anamorphic lens system is maintenance-free. It will deliver many years of trouble-free service as delivered from the factory.

To clean: Lightly blow off any surface debris from the lens. If needed, clean the lens using standard cleaning supplies while the projector is on (be careful not to look directly into the light beam of the projector).

Clean the metal components with a damp cloth, make sure not to drip any water into the enclosure.

The sled internal drive is permanently coated to run smoothly. Keep the rail linear bearing clean, dry and contaminant free.

In case of accidental debris and/or liquids spilled onto the system, you can clean all contaminants with water and wipe down with denatured alcohol. The drive mechanism relies upon a clean rail to operate smoothly.

The linear bearing, and all enclosed bearings are constructed of specialized material to ensure smooth operation. Remove power source before cleaning. Outside lubricants will gum up the mechanism, and possibly produce a film across the projector and anamorphic lens.



*Never use lubricants of any nature on any part of the mechanism.*

## Specifications

<b>Electrical Characteristics</b>	
Model	Optoma BX-AL133 Motorized Sled
Power Supply	110/120v, 50-60 Cycles
Power Supply Output	9V DC, 0.5A
Operating Voltage	9-18V DC, 0.5-1.5A
Operating Current Draw	Typical 650mA, max 1.2A
Standby Current Draw	60mA
Trigger Jack	3.5 mm Mono or Stereo Jack, 12V, Tip Positive
Remote IR Jack	2.5 mm Stereo Jack (Supplied)
Remote	3oz, IR Emitter
IR Receivers	2, One Fixed, Another Remotely Attached (Optional)
IR Range	50 ft from IR Sensor
IR Carrier Frequency	38 kHz
Batteries	2 AAA (for Remote)
Certification	FCC, CE (BX-AL133 Motor Drive Unit) UL Class II (Power Supply Only)
Design Life	Greater than 250,000 rail traversals

<b>Physical Characteristics</b>	
Weight	5 lbs
Dimensions	See accompanying drawings

## Dimensions

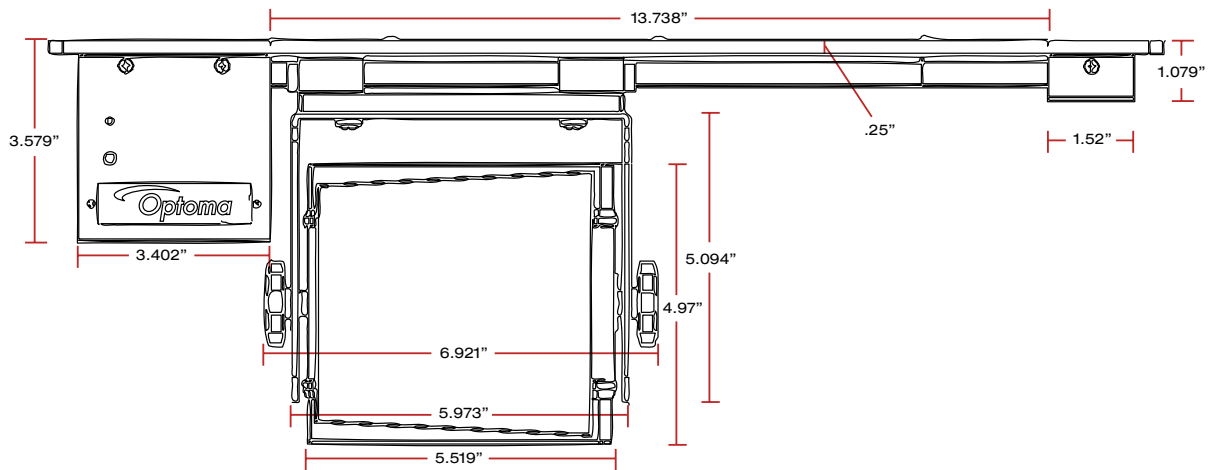
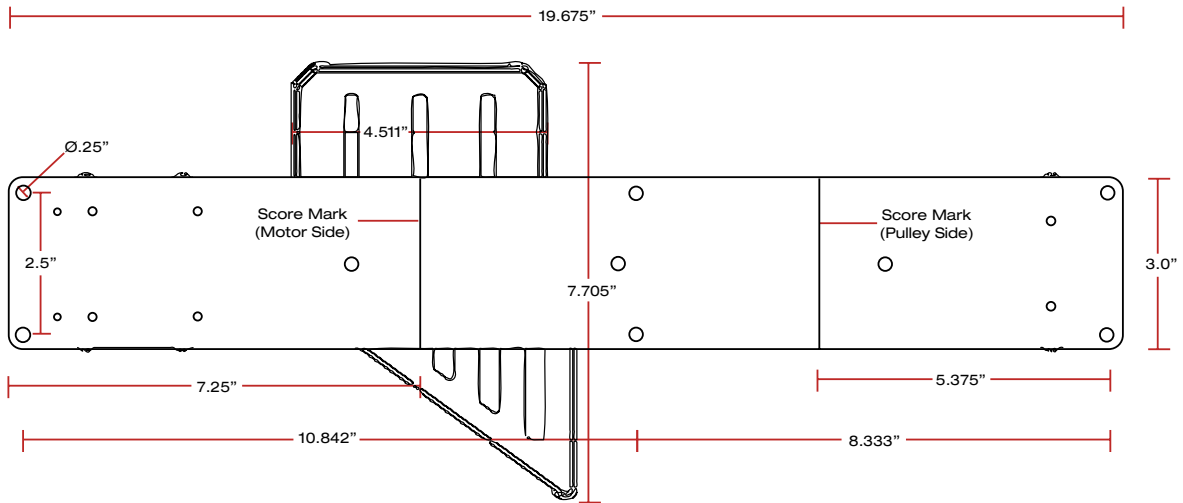

## Warranty

Optoma Technology Inc. warrants this product to be free of defects in original workmanship and material for a period of twenty-four (24) months from the date of purchased. During this period, a defective unit may be repaired or replaced, at the discretion of Optoma Technology Inc., by returning it in its original packaging with a copy of your receipt. This warranty does not cover damage resulting from tampering, lack of prudent care, accident or misuse (including contravention of cautions stated in the instructions), or any cosmetic damage not reported within fifteen (15) days of purchase. All liability for damage is limited to the cost of the product and does not include incidental injury or peripheral damage to other equipment, persons or property. Optoma Technology Inc. is not responsible for personal injury resulting from faulty installation. A service charge may be applied to any returned product requiring cosmetic attention, or to the repair of any damage not covered under this warranty.

## Addendum: Adapter Plate

This attachment plate is designed to be installed onto a ceiling mounted projector. The location or orientation of the ceiling mount does not need to change.

### Contents

- 1 Lens Plate
- 1 (Bag) Projector Attachment Parts
- 1 Assembly Kit (Includes)
  - 2 Plate Hook Assemblies
  - 1 Chain (6 ft)
  - 4 Chain Ends
  - 4 Lens Mounting Assemblies
  - 4 Sled Mounting Screws
  - 2 Sled Safety Assemblies
  - 1 Hex Key

### Required Tools and Equipment

- 2 Ceiling Hooks (40 lbs Capacity Each)
- 1 Phillips Screwdriver
- 1 Pair of Pliers
- 1 Strong Pair of Scissors or Wire Cutters

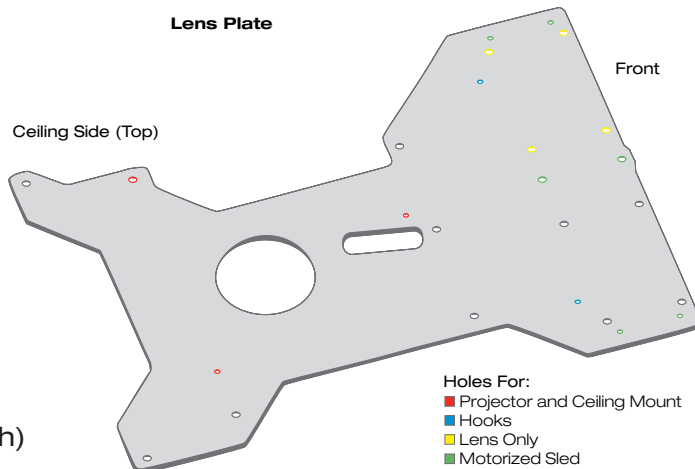

1. **INSTALL PLATE HOOK ASSEMBLIES.** Use the pliers to bend the closed-end of the hooks apart just enough to insert the end of the chain. Install the plate hook assemblies in the two holes. Place one hook end on the top side and then continue the assembly down in the order of nut, washer, lens plate, washer, lock washer and nut. Arrange the assembly so that the plate is in the center of the threaded hook shaft.

2. **ATTACH LENS PLATE.** Remove the projector from the ceiling and the ceiling mount adapter plate. Position the ceiling mount adapter plate over the lens plate and the projector. Line up the holes of the lens plate (labeled holes for projector and ceiling mount in the diagram above) with the holes of the ceiling mount and projector. Install the silver screws from the attachment parts bag.



*Ceiling mount hardware may vary. If the provided screws are not long enough, purchase the longest metric M4 screws without exceeding the depth of the projector mounting holes for the greatest security.*

3. **MOUNT PROJECTOR ASSEMBLY.** Securely connect the ceiling mount adapter, lens plate and projector assembly to the ceiling mount and then adjust the ceiling mount to provide the proper 16:9 image orientation in the center of your 2.35:1 screen.



4. **INSTALL CHAINS.** Hold the chain to the ceiling so that one end of the chain hangs just above one of the installed plate hooks. Mark the ceiling location and repeat for the other chain hook. Procure and install the ceiling hooks at those locations small enough to accept a chain end, and strong enough when installed to support approximately 40 pounds (or more). The type of hook and method of installation may depend on the type of ceiling you have. Cut the chain to make chain segments. The ones that come closest to supporting the lens plate when attached to the chain ends should be the ones that are attached to the plate and ceiling hooks. Install the lens chains and adjust the nuts on the plate hooks to make the chains tight, but without raising the front of the plate. Tighten the plate hook nuts to compress the lock washer in the plate hook assembly.

5. **MOUNT THE ANAMORPHIC LENS.**

#### INSTALLATION WITHOUT THE MOTORIZED MOUNT:

- a. Remove the lens from its lens bracket.
- b. Orient the lens bracket to the lens plate so that the angled sides of the lens bracket are toward the back of the plate. Install the four lens mount assemblies (large assemblies with white spacers) from the top down through the four holes that are for the lens in the order of screw, flat washer, lens plate, white spacer, lens bracket, flat washer, lock washer and nut. Use the hex key to tighten the nuts so that the lens mount assemblies are centered in the elongated lens bracket holes.
- c. Turn the projector on and project a full, yet still 16:9 image from the projector. Carefully install the lens and adjust the tilt to equalize the top and bottom image geometry while positioning the lens vertically to center the output beam. Tighten the lens knobs.

#### INSTALLATION WITH MOTORIZED MOUNT:

- a. Do Not Connect the Power of the Motorized Mount at this Time.
- b. Position the motorized mount on the bottom side of the lens plate so that the six holes (refer to the diagram on the previous page) in the lens plate line up with the six holes in the flat side of the motorized mount. Insert the four small 1/4" screws through the four small holes of the lens plate into the motorized mount and tighten.
- c. Insert the sled safety assemblies through the remaining two holes from bottom up in the order of screw, motorized mount, lens plate, washer, lock washer and nut. Tighten both safety assemblies.
- d. Refer to the motorized mount user manual for additional instructions at this time.



*Use extreme caution and appropriate hardware when installing heavy objects to a ceiling. Periodically check all fasteners and connection hardware to be sure they have not come loose. Improper installation may lead to an increased risk of your equipment becoming unstable and possibly causing injuries.*

## **Addendum: The Finished Product**

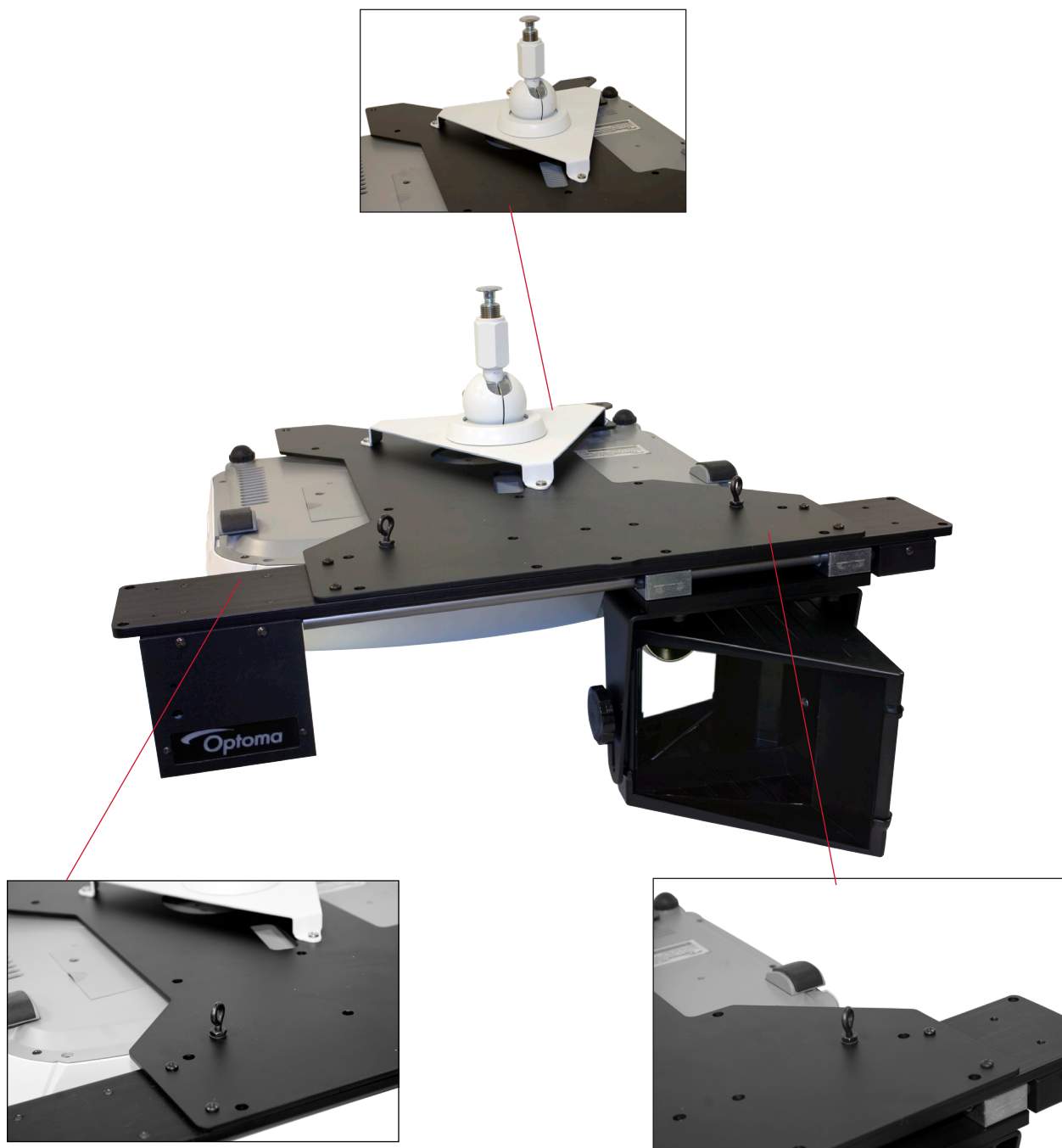



## Canada

5630 Kennedy Road  
Mississauga, ON, L4Z 2A9, Canada  
Tel: 905-361-2582  
Fax: 905-361-2581  
[www.Optoma.com](http://www.Optoma.com)

## USA

715 Sycamore Drive  
Milpitas, CA 95035, USA  
Tel: 408-383-3700  
Fax: 408-383-3702  
[www.OptomaUSA.com](http://www.OptomaUSA.com)

We make finding the  
Writeboard easy

**TOUCHBOARDS**

1-866-942-6273 .COM

205 Westwood Ave, Long Branch, NJ 07740

Phone: 866-94 BOARDS (26273) / (732)-222-1511

Fax: (732)-222-7088 | E-mail: [sales@touchboards.com](mailto:sales@touchboards.com)

Optoma Technology, Inc.

715 Sycamore Drive, Milpitas CA 95035

Tel: 408-383-3700 • Fax: 408-383-3702

For more information, please visit [www.Optoma.com](http://www.Optoma.com).

Specifications subject to change without notice. Copyright © 2007 Optoma Technology, Inc.

The logo features a red swoosh above the word "Optoma" in a white, sans-serif font.