

Installation Instructions

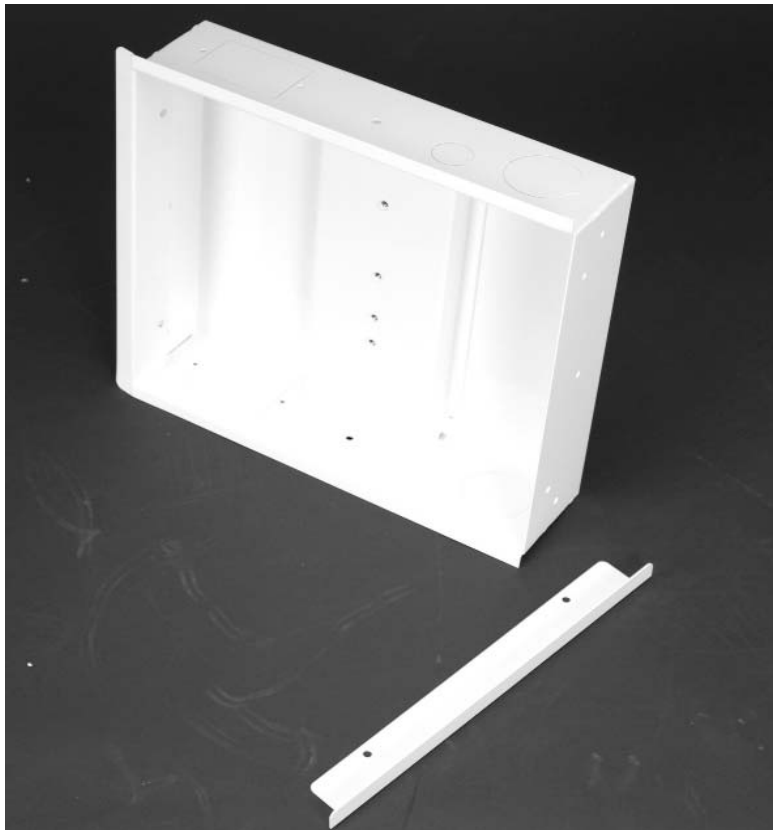

INW-AM200 In-Wall Mounting Box

Premier Mounts



Touchboards

205 Westwood Ave, Long Branch, NJ 07740
Phone: 866-94 BOARDS (26273) / (732)-222-1511
Fax: (732)-222-7088 | E-mail: sales@touchboards.com



TABLE OF CONTENTS

Warning Statements 3

Parts List 4

Installation Tools 4

Mount Location 5

Wall Cut-Out 5

Attaching the INW-AM200 6

Side Cover Installation 6

AM2/PTM Backplate Installation 7

Final Installation 7

Technical Specifications 8

Warranty 8

Contact Premier Mounts 8

Notes 8

WARNING: ELECTRICAL SHOCK HAZARD!! Cutting or drilling into electrical wires and cables can cause **DEATH** or **SERIOUS PERSONAL INJURY!** Always make certain the area behind the mounting surfaces is free of electrical wires and cables before cutting, drilling, or installing the in-wall box

WARNING: EXPLOSION AND FIRE HAZARD! Cutting or drilling into gas plumbing can cause **DEATH** or **SERIOUS PERSONAL INJURY!** Always make certain the area behind the mounting surface is free of gas, water, waste, or any other plumbing before cutting, drilling, or installing the in-wall box.

WARNING: STRUCTURAL FAILURE HAZARD! Ensure removal of center stud will not cause unacceptable loss of structural strength. Consult a qualified building contractor and applicable building codes. Failure to take adequate precautions can cause **DEATH** or **SERIOUS PERSONAL INJURY!**



Warning Statements

WARNING: THE WALL STRUCTURE MUST BE CAPABLE OF SUPPORTING AT LEAST A MINIMUM WEIGHT OF 100 LBS. IF NOT, THE WALL MUST BE REINFORCED. PROPER INSTALLATION PROCEDURE BY A QUALIFIED SERVICE TECHNICIAN, AS OUTLINED IN THE INSTALLATION INSTRUCTIONS, MUST BE ADHERED TO. FAILURE TO DO SO COULD RESULT IN SERIOUS PERSONAL INJURY, OR EVEN DEATH.

WARNING: SAFETY MEASURES MUST BE PRACTICED AT ALL TIMES DURING THE INSTALLATION OF THIS PRODUCT. USE PROPER SAFETY GEAR AND TOOLS FOR THE INSTALLATION PROCEDURE TO PREVENT PERSONAL INJURY.

WARNING: PRIOR TO THE INSTALLATION OF THIS PRODUCT, THE INSTALLATION INSTRUCTIONS SHOULD BE READ AND COMPLETELY UNDERSTOOD. THE INSTALLATION INSTRUCTIONS MUST BE READ TO PREVENT PERSONAL INJURY AND PROPERTY DAMAGE. KEEP THESE INSTALLATION INSTRUCTIONS IN AN EASILY ACCESSIBLE LOCATION FOR FUTURE REFERENCE.



Indicates that the power plug is to be disconnected from the power outlet.



Safety precautions must be taken at all times.



Warning and Caution statements.



A secure structure must support the weight, or load, of the display. When mounting to a wall that contains wooden studs, dead center of the wooden stud must be confirmed prior to installation.



Do not install on a structure that is prone to vibration, movement or chance of impact. Failure to do so could result in damage to the display and/or damage to the mounting surface.



Do not install near heater, fireplace, direct sunlight, air conditioning or any other source of direct heat energy. Failure to do so may result in damage to the display and could increase the risk of fire.



At least two qualified people should perform the installation procedure. Injury and/or damage can result from dropping or mishandling the display.



Recommended mounting surfaces: wooden studs and solid-flat concrete. If the mount is to be installed on any surface other than wooden studs, use suitable hardware (which is commercially available).







Contact Premier Mounts with any technical/ installation questions.

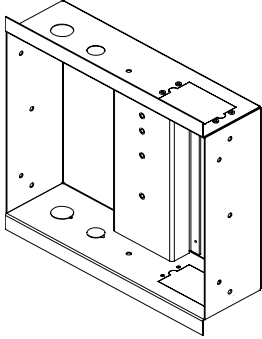
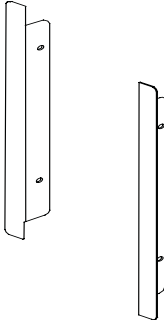

Parts List

NOTE: This mounting box is shipped with all installation hardware and components. Make sure that none of these parts are missing and/or damaged before beginning installation. If there are parts missing and/or damaged, please stop and contact Premier Mounts - (800) 368-9700.

NOTE: It is strongly recommended that a licensed electrician supply wire and power to the in-wall mounting box. Pre-wiring must be complete prior to installing the INW-AM200.

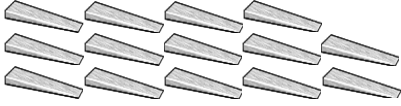
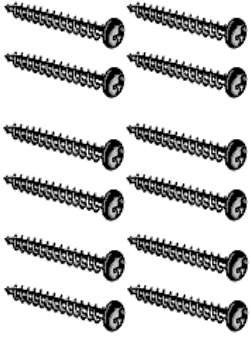
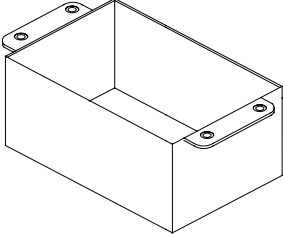
<p>INW-AM200 (Qty 1)</p> 	<p>INW-AM200 Side Covers (Qty 2)</p> 
<p>6-32 X 1/2" Phillips Screws (Qty 4)- For use with electrical box installation (see NOTE above)</p> 	<p>1/16" Clear Bumper Pad (Qty 4)</p> 
<p>Split Lock Washer (Qty 4)</p> 	<p>1/4-20 x 1/2" Screw (Qty 4)</p> 
<p>1/4" Wood Shims (Qty 14)</p> 	<p>#14 x 1-1/4" Wood Screws (Qty 12)</p> 
<p>In-Wall Electrical Box (Qty 1)</p> 	

Installation Tools

Phillips Head Screw Driver

Pencil

Tape Measure

Drywall Saw

Portable Drill

Level

Stud Finder (Commercially Available)

Hammer



Mount Location

WARNING: Always make certain the area behind the mounting surface is free of electrical wires, cables, and pipes before cutting, drilling, or installing the mounting screws.

NOTE: It is strongly recommended that a licensed electrician supply wire and power to the in-wall mounting box. Prior to installing the INW-AM200, please complete all wiring and allow for the appropriate amount of slack.

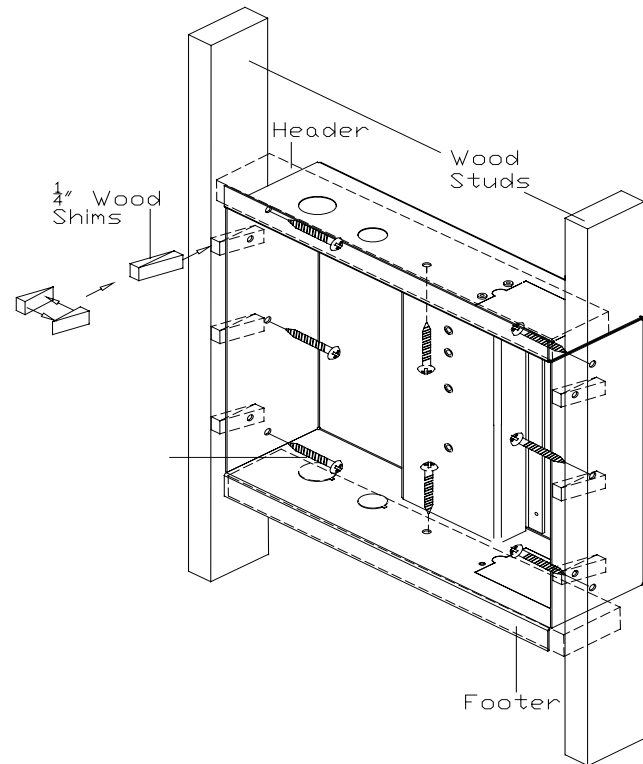
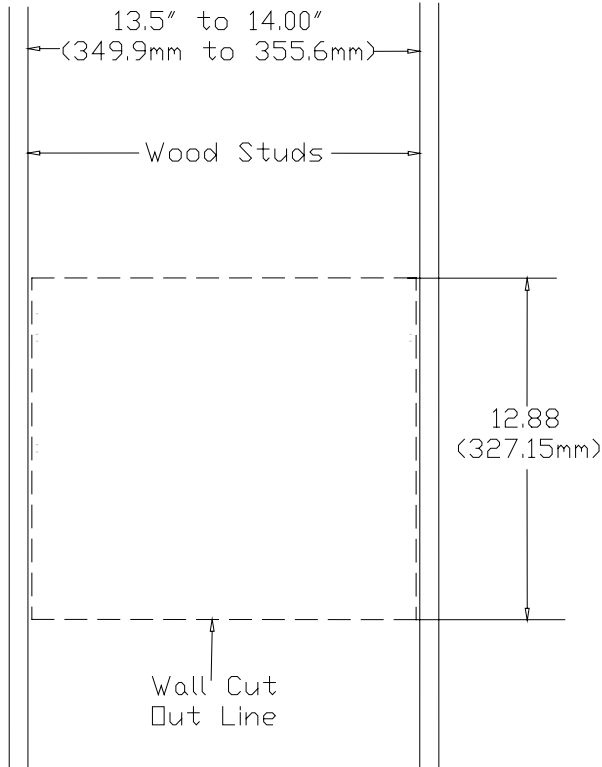

Wall Cut-Out

1. Determine where the location of the mount/display will be.

NOTE: While installing the INW-AM200, you will possibly come into contact with electrical wires, plumbing, and insulation. Take the necessary precautions before proceeding with this installation.

2. Use a stud finder (commercially available) to locate the wood studs that will be used for the installation. Mark the stud locations with a pencil.
3. Center and level the INW-AM200 between the marked studs. Using the INW-AM200 as a template, draw a pencil line completely around the housing.
4. Cut the drywall on the outside edge of the line and remove the drywall. Make sure that the cut is flush and even with the vertical wall stud.

NOTE: All existing wires must be moved and anchored to either side of the mounting area (attach in a corner where the wood stud and the rear wall surface connect).

Attaching the INW-AM200

1. Place the INW-AM200 in the opening.
2. Place six (6) 1/4" wood shims on each side of the INW-AM200 (between the INW-AM200 and the wood stud).
3. Insert the six (6) #14 x 1-1/4" wood screws into the mounting points. Do not overtighten these screws.

NOTE: The wood shims must be placed between the wood stud and the INW-AM200. Please refer to the figure above for correct placement of the wood shims. Use wood shims as required.

NOTE: The purpose of the wood shims is to help center the unit, as well as provide a tight fit when all the wood screws are tightened down. Use as many shims as it takes to ensure that the box is level and centered.

4. Once the wood shims are inserted, tighten down all of the wood screws.

NOTE: If the installer chooses to add a header and a footer for additional support, two (2) spare #14 x 1-1/4" wood screws have been included (see figure above).



Side Cover Installation

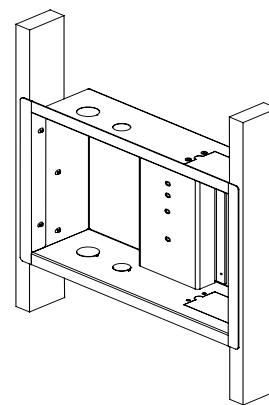
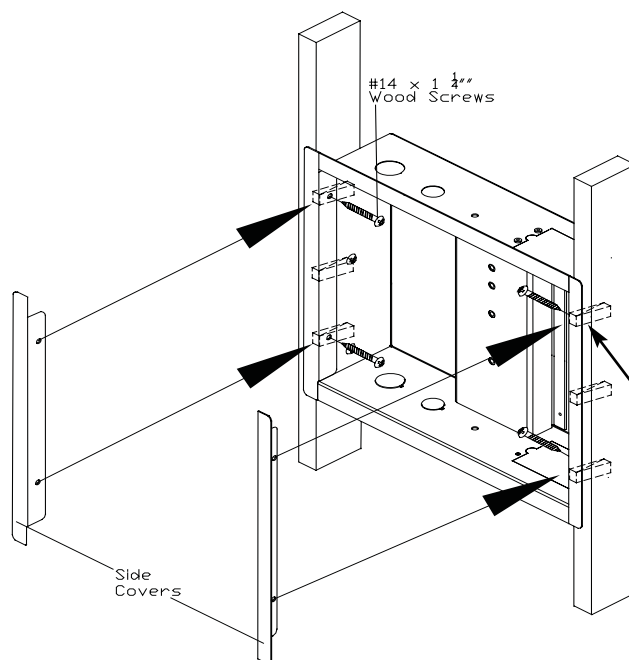

INW-AM200 Installation Complete

NOTE: When attaching the side covers, make sure that the 1/4" wood shims are in line with the side cover mounting holes. If the wood shims split while attaching the wood screw, don't panic. These wood shims have been designed to split in half to cover more area.

1. To attach the side covers, use four (4) #14 x 1-1/4" wood screws to attach the side covers.
2. Line up the mounting holes on the side covers with the mounting holes that are located on the INW-AM200.
3. Once the mounting holes are located, insert the four (4) #14 x 1-1/4" wood screws and tighten.

In-Wall Electrical Box Installation

NOTE: It is best to have a professional install this product.

NOTE: It is strongly recommended that a licensed electrician be hired to supply wire and power to the in-wall mount. Wiring must be ran prior to installing the INW-AM200. The cutout in the mounting box is sized to accommodate a standard RACO junction box. Route all audio/ visual cables and power wires through the cutouts.

1. Use four (4) 6-32 x 1/2" Phillips screws to attach the electrical box to the mounting box.

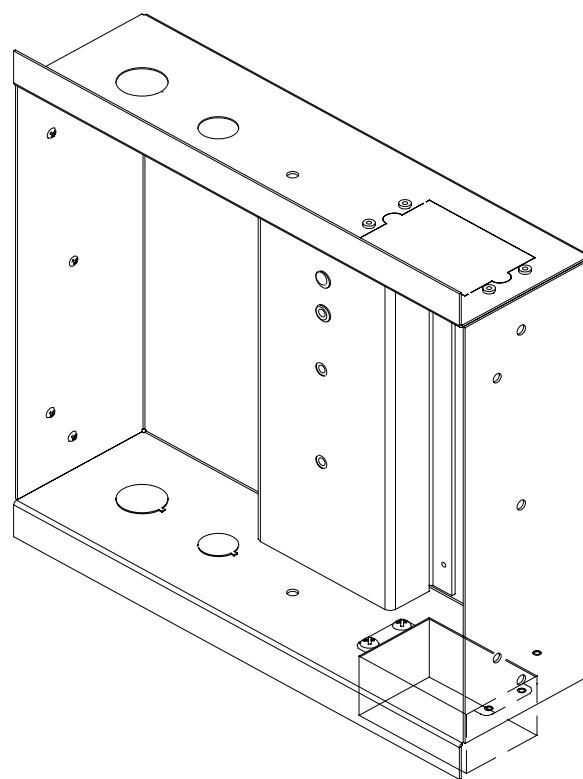
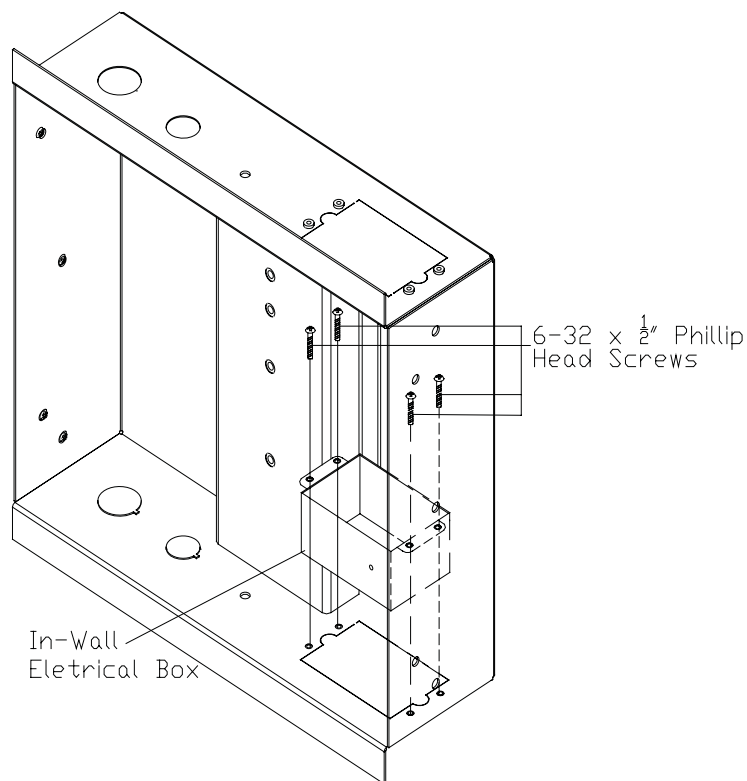



AM2/PTM Backplate Installation

NOTE: See the AM2/PTM installation manuals for further installation procedures.

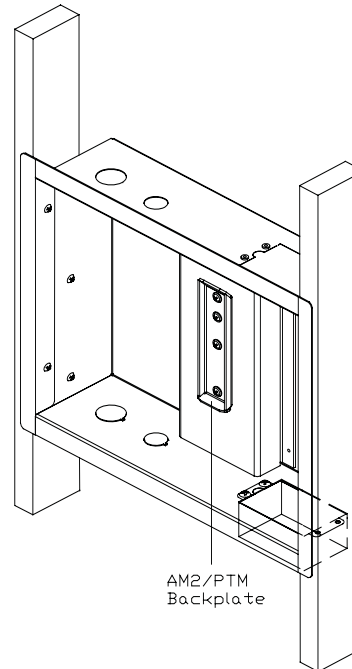
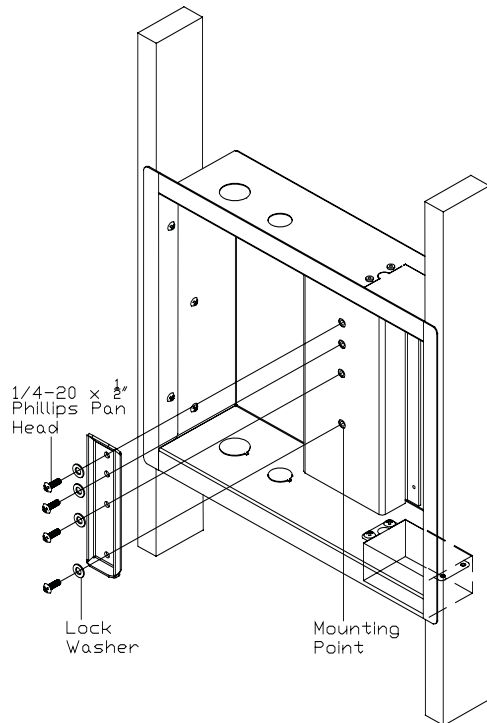

Backplate Installation Complete

1. Use four (4) 1/4-20 x 1/2" Phillips head screws and four (4) lock washers to attach the AM2/PTM backplate to the INW-AM200.
2. Tighten using a Phillips head screwdriver.

Final Installation

NOTE: See the AM2/PTM Installation Instructions for final installation procedures.

NOTE: Place four (4) 1/16" clear bumpers on the mount where the mount comes into contact with either the wall surface or the INW-AM200.

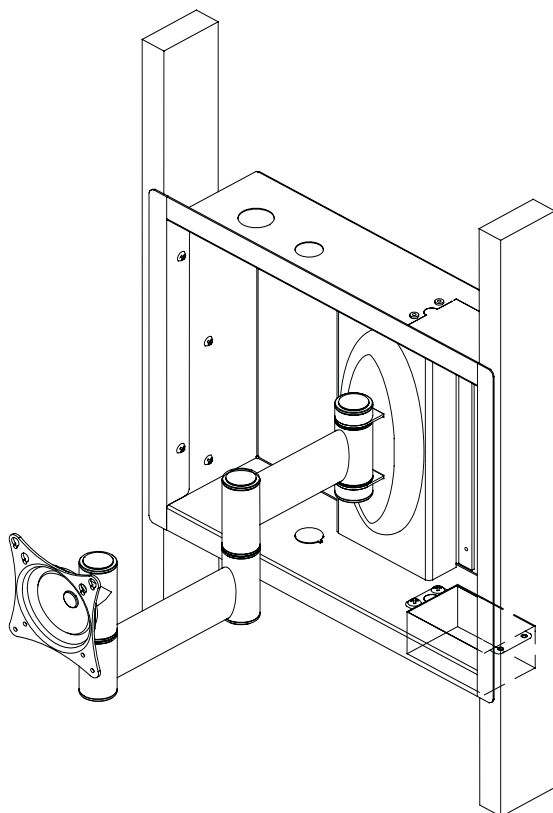

AM2 Installation Complete

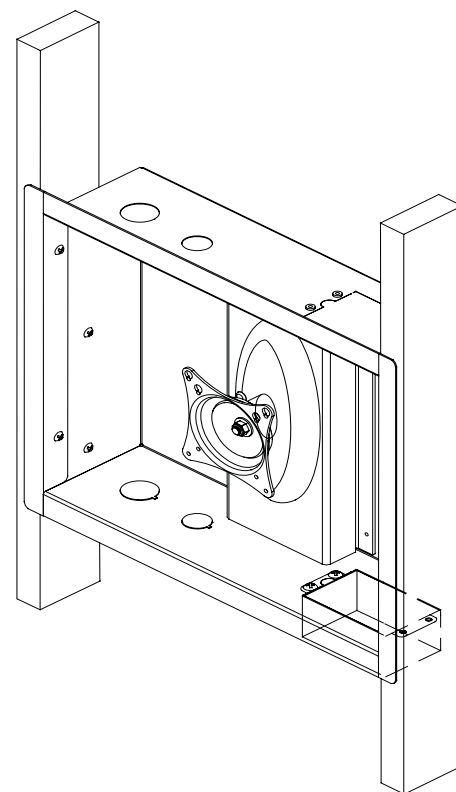

PTM Installation Complete



Technical Specifications

All measurements in inches/(mm).

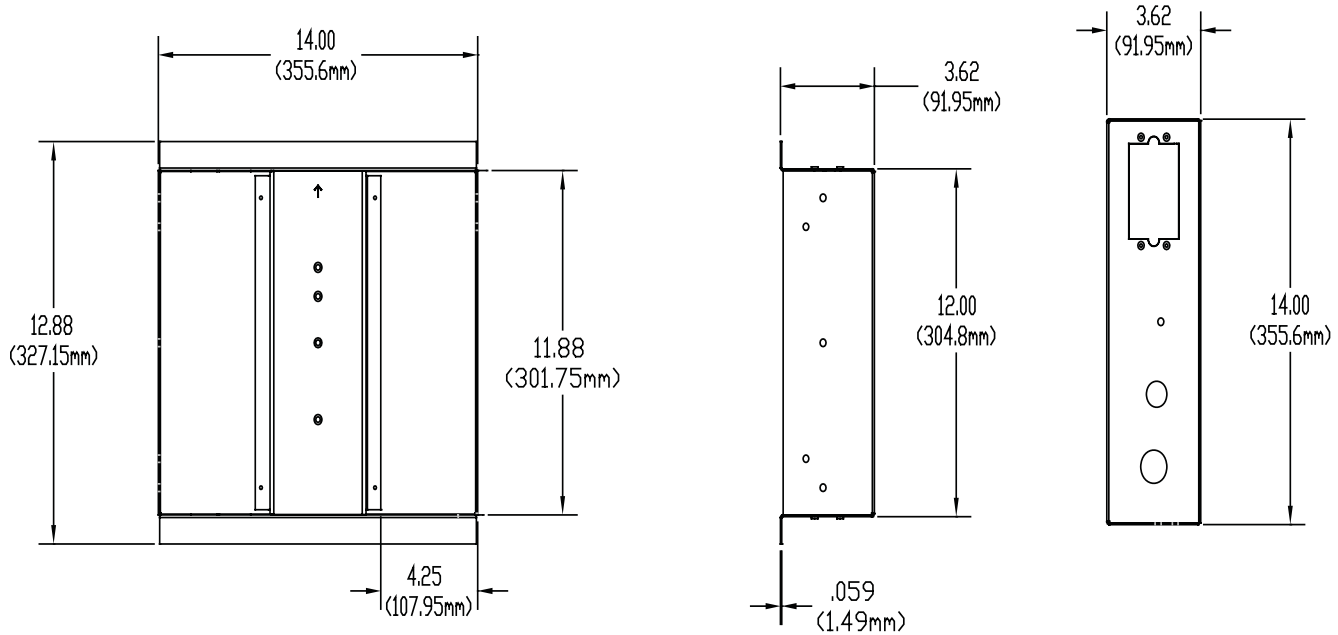

Warranty

Limited Lifetime Warranty

All Premier Mounts products carry a limited lifetime warranty from ship date against defects in materials and workmanship. Premier Mounts is not liable for improper installation that results in damage to mounts, adapters, display equipment or personal injury. Any modification to the existing mount will void the manufacturers' warranty.

DISCLAIMER OF WARRANTY.

THE FOREGOING WARRANTY IS IN LIEU OF ALL OTHER WARRANTIES, EXPRESS OR IMPLIED, INCLUDING BUT NOT LIMITED TO THE IMPLIED WARRANTIES OF MERCHANTABILITY AND FITNESS FOR A PARTICULAR PURPOSE.

Contact Premier Mounts

In the event of missing and/or damage equipment, or technical questions, the following information can help in the completion of the installation.

Customer Service - (800) 368-9700

Technical Support - techsupport@mounts.com

Notes

NORTH AMERICA

3130 E. Miraloma Ave.
 Anaheim, CA 92806 USA
 USA and Canada -
 Phone: 800-368-9700
 Fax: 800-832-4888
 www.mounts.com

EUROPE

Swallow House,
 Shilton Industrial Estate,
 Shilton, Coventry, England
 CV79JY
 Phone: +44 (0) 2476 614700
 Fax: +44 (0) 2476 614710

AUSTRALIA, NEW ZEALAND, OCEANIA (DISTRIBUTOR)

P.O. Box 295
 Mordialloc Victoria 3195
 Australia
 Phone: 03 9586 6330
 www.premiermounts.com.au