

# INSTALLATION MANUAL

## PBL-UMS

Universal projector mount



**Touchboards**

205 Westwood Ave, Long Branch, NJ 07740  
Phone: 866-94 BOARDS (26273) / (732)-222-1511  
Fax: (732)-222-7088 | E-mail: sales@touchboards.com



**PREMIER  
MOUNTS™**

The original holding company

3130 E. Miraloma Ave. Anaheim, CA 92806 Phone: 800 368-9700 Fax: 800 832-4888

[www.mounts.com](http://www.mounts.com)

## Features:

Congratulations on your recent purchase of your PBL-UMS universal projector ceiling / wall mount kit. Designed for projectors weighing 25 lbs (13kg) or less. The mount is very easy to install and loaded with additional “no cost” installation features built into the mount. These features allow you to optimize your projector’s position to the screen for best projector performance and picture quality.

- Adjustable-height 9” – 12.5” suspension channel to lower the projectors height (can be removed for low-profile mounting of only 2.5”)
- 0°- 45° angled ceiling compensation
- Mounts to ceiling or a wall
- Tilt / roll up to 20°+
- Rotates 360°
- Positive locking in any set position
- Quick release system for easy projector mounting and removal
- Cables can be routed inside the height extension channel
- Upper ceiling plate allow for single wood stud mounting and cable insertion through the ceiling plate for clean appearance

## Contents

- Safety & Precautions
- Mount diagrams
- PBL-UMS universal mount assembly
- Parts list
- Getting the projector ready
- Preparing the mount
- Securing the bracket to the projector
- Leveling the mounting bracket
- Securing the upper assembly ceiling plate
- Low-profile installation
- Securing the projector to the upper assembly
- Final adjustments
- Installing the plastic caps

## Safety & Precautions

**WARNING** Safety precaution measures must be practiced at all times during the installation of this product. Use proper safety gear and tools for the installation procedure to prevent personal injury or damage to the projector and /or mount.

### WARNING!

The wall or ceiling structure must be capable of supporting at least five (5) times the weight of the projector. If not, the wall or ceiling must be reinforced. Proper installation procedure by qualified personnel as outlined in the installations instructions must be adhered to. Failure to do so could result in serious personal injury.

The entire installation instructions should be fully read and understood, including all of the safety symbols and safety precautions, before beginning installation. The installation instructions should be read, understood and followed to prevent personal injury or property damage. Keep these installation instructions in an easily accessible location for future reference.



Indicates that the power plug is to be disconnected from the power outlet.



Contact Premier Mounts for any questions



Safety precautions must be taken at all times.

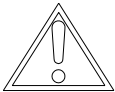

Warning and caution in general



A secured structure wooden stud wall must always support the weight or load of the projector. Always confirm the center of the wood stud before beginning the installation.



Do not install in locations where there is vibration, movement or danger of impact. Failure to do so could result in excessive projector vibration or falling from the wall or ceiling causing damage and injury.



Do not install near heater, fireplace, direct sunlight or air conditioning or any other source of direct heat energy. Failure to do so may result in damage to the projector.



Qualified personnel should always perform the installation work. Injury and damage can result from dropping or mishandling the projector.



Mounting structure recommended wood studs, solid-flat concrete, and reinforced metal studs. If installing the mount on other than wood studs use (commercially available) suitable hardware.

# Mount Diagrams

## MOUNTING HARDWARE

- (4) M4 x 12 Hex head screws
- (4) M5 x 12 Hex head screws
- (4) M6 x 12 Hex head screws
- (3) #14 x 2" Wood screws
- (4) Plastic vinyl caps
- (1) M5 Allen wrench

Note: Dimensions are shown both in inches and (mm)

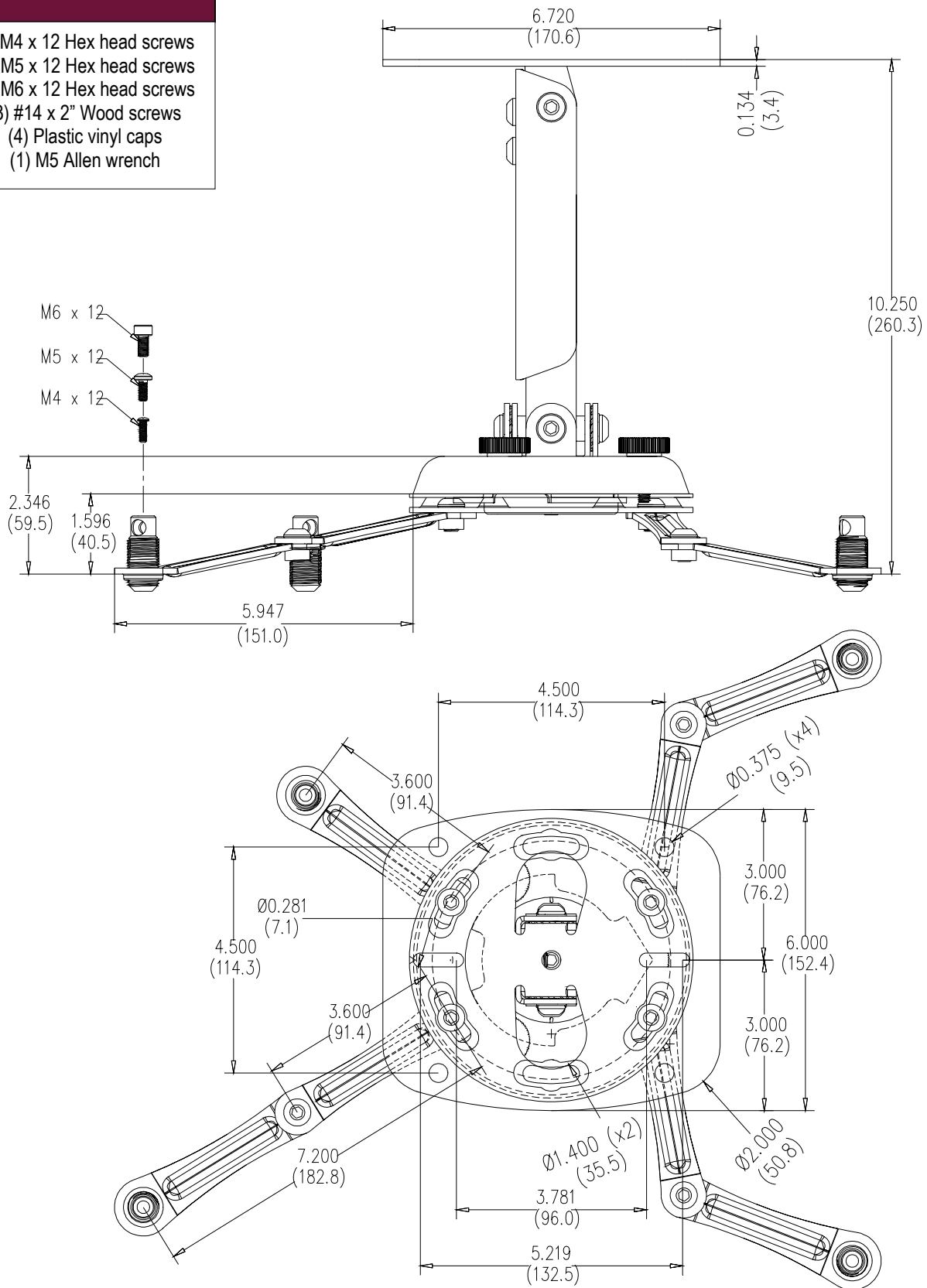

# PBL-UMS Universal mount assembly

A	Single wood stud mounting points
B	Solid structure mounting points
C	Ceiling plate
D	Allen wrench
E	Height adjustable screws
F	Tension knobs
G	Safety knob
H	Security screws
I	Leveling barrels
J	Universal mounting bracket
K	Leg assembly
L	Projector (not supplied)
M	Tri-lock opening

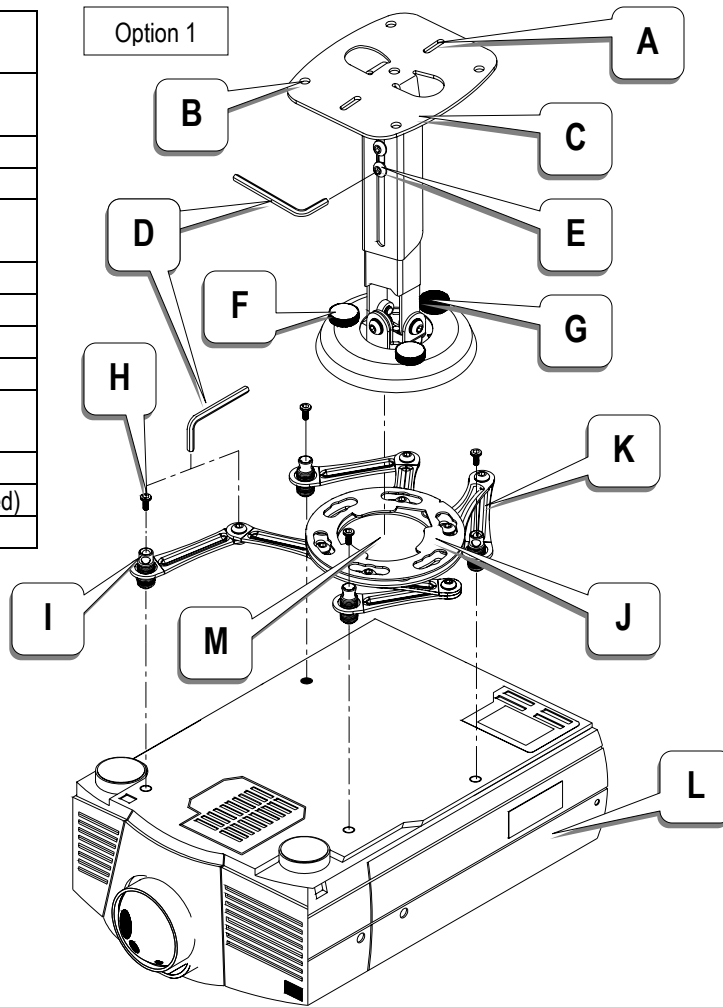

**Note:** The four (two piece) leg assemblies can be used as single leg or any combination of single and dual legs together as shown in options 1 and 2  
The number of legs may vary depending on the number of mounting points found on the bottom of your projector.

Combination leg

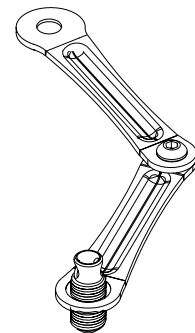

Single leg

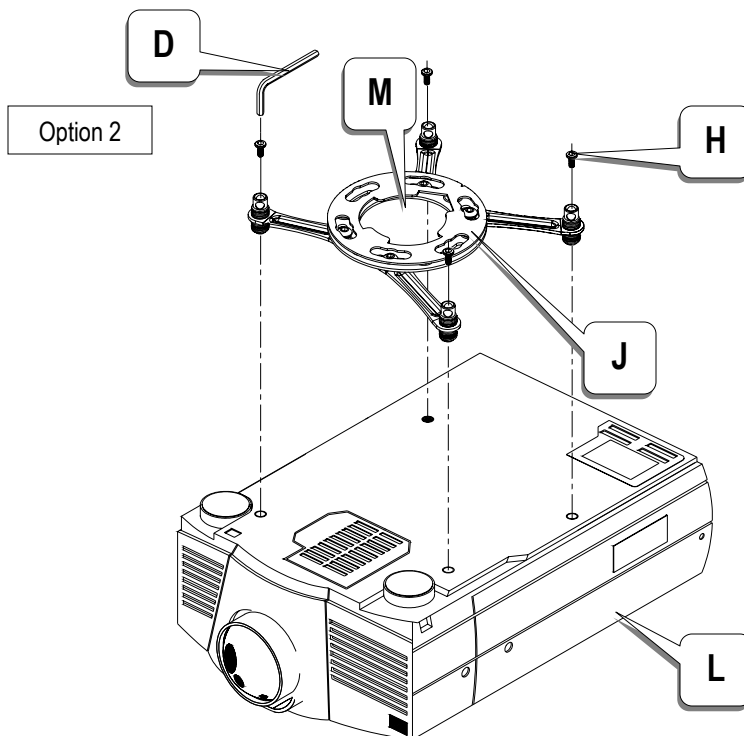
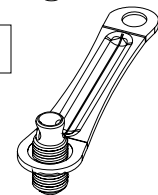

## Parts list

Remove all the components from the box. Confirm that no components are missing from the package. If parts are missing **STOP**. Do not proceed with the installation. Contact PREMIER MOUNTS.

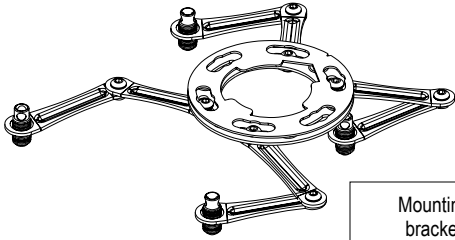

Mounting  
bracket



(4) M4 x 12 Hex head  
screws

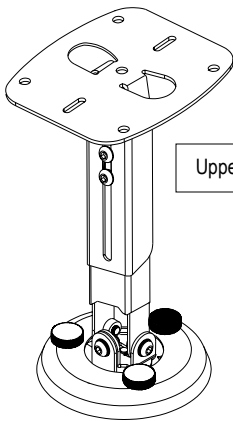

Upper assembly

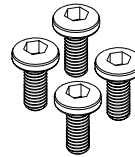

(4) M5 x 12 Hex head  
screws

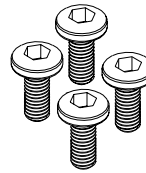

(4) M6 x 12 Hex head  
screws

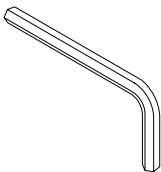

M5 Allen wrench

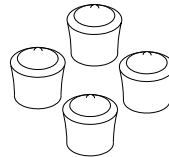

(4) Plastic barrel caps

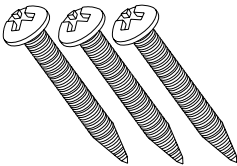

(3) Lag screws (#14 x 2")

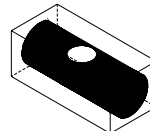

(1) Level

## Getting the projector ready

**WARNING:** Proper installation procedure by qualified personnel as outlined in the installation instructions must be adhered to. Failure to do so could result in serious personal injury and possible damage to the projector.

**CAUTION:** THE PROJECTOR IS FRAGILE HANDLE WITH CARE AT ALL TIMES.

**NOTE:** Review the projector's manufacturer's operation manual and refer to the ceiling mounting section of the operator's manual. Here you will normally find important reference information regarding installation dimensions such as (distance from the screen to the lens of the projector, top of the lens placement to the top screen etc.

Adherence to these recommendations during your installation will enhance the quality of your final image on the screen.

### Step 1

Carefully invert the projector and place it on a smooth flat surface. Identify the number of mounting points and screw thread (pitch) size. Most projectors have either three or four mounting points and are M4, M5, or M6 in thread size.

See figure 1

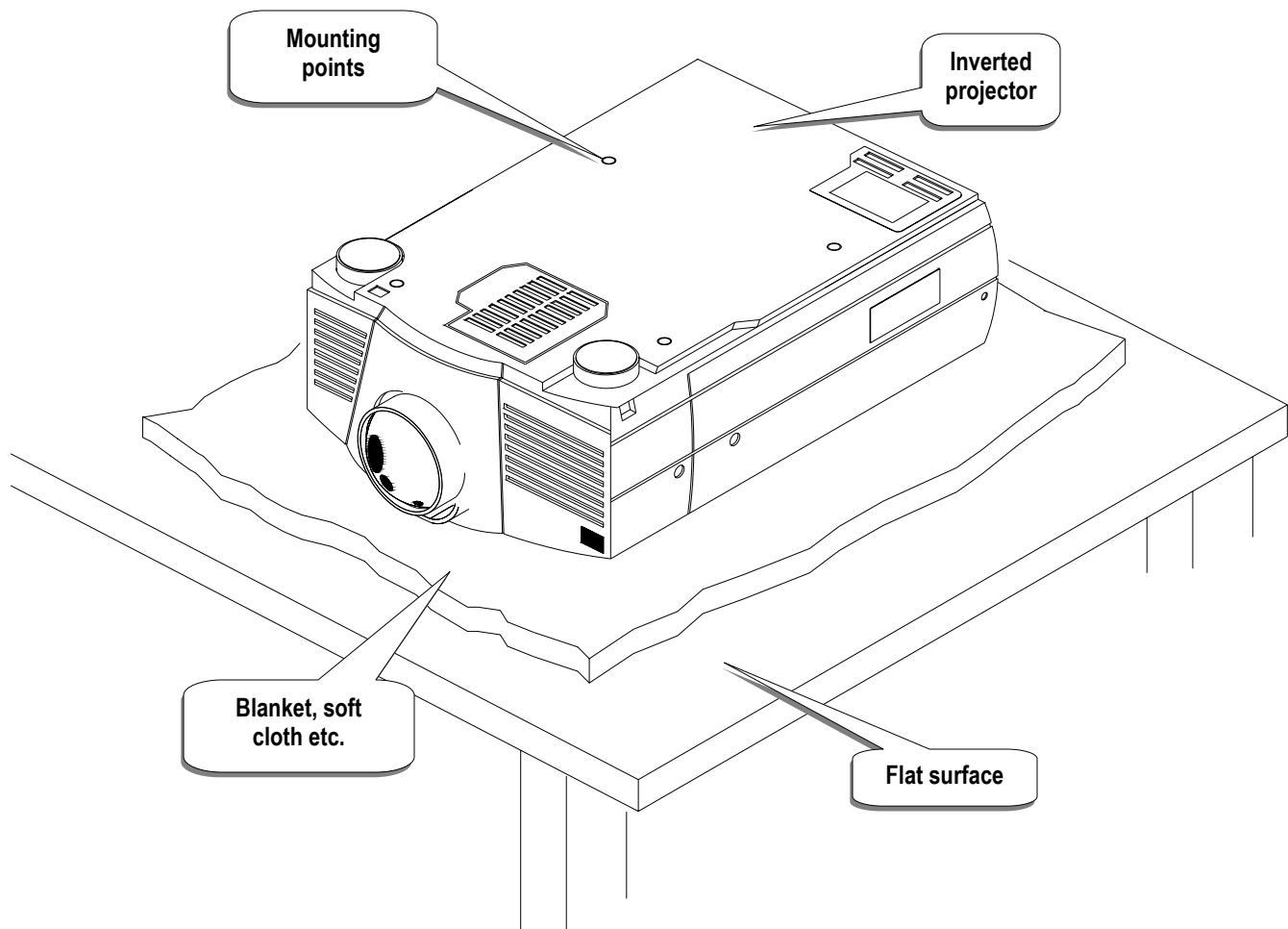
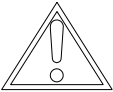

FIGURE 1

## Preparing the mount

### Step 2

Separate the upper assembly from the projector mounting bracket by slightly loosening the two tension knurl knobs to create free play between the bracket tri-lock assembly and the upper section tri-lock assembly points. Next loosen the security screw knurl knob far enough to allow the two parts to be rotated 180° apart and separate.

See figure 2 and 3.



FIGURE 2

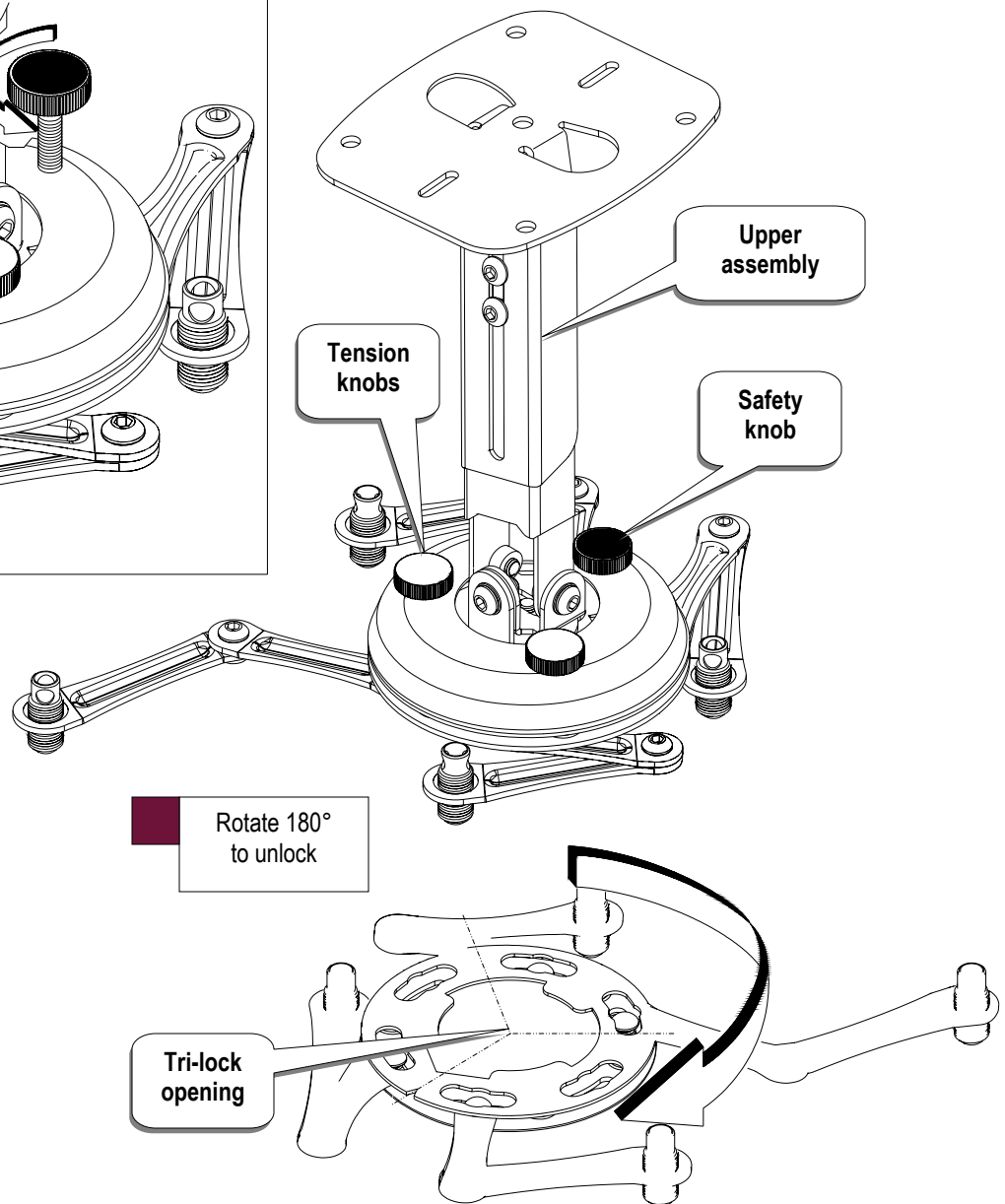
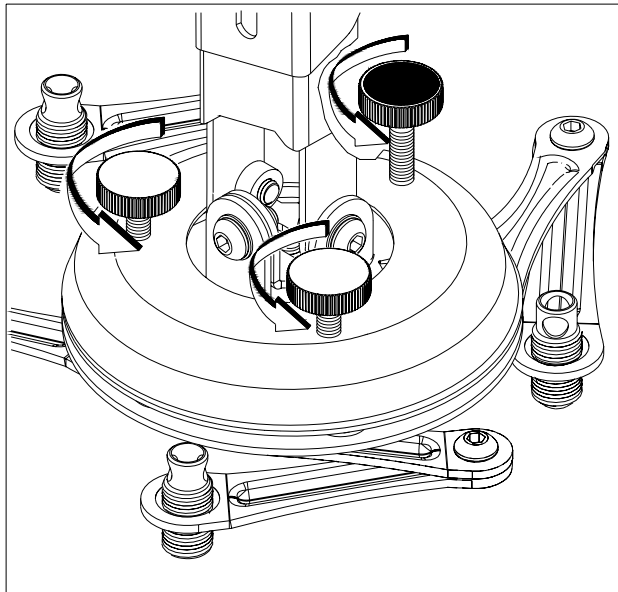

FIGURE 3



## Securing the bracket to the projector

**NOTE:** The two piece mounting legs are designed to allow routing of the legs around critical ventilation screens on the base of the projector as shown. You may also reduce the two piece leg to a one piece leg as shown for a better overall fit to the projector.

See figure 5, 6, 7.

### Step 3

Locate the mounting points on the bottom of the projector and use the appropriate number of mounting legs. Select the mounting hardware that your projector requires and loosely install the universal mount to your projector.

**NOTE:** The levelers and leg assembly screws must be loose in order to adjust the height of the mounting bracket.

FIGURE 5

Two piece leg

One piece leg

FIGURE 6

FIGURE 7

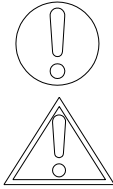

M5 Allen wrench

M6 x 12 Hex head screw

M5 x 12 Hex head screws

M4 x 12 Hex head screws

Inverted projector

Leveling barrels

Line up the leveling barrels to the mounting points.

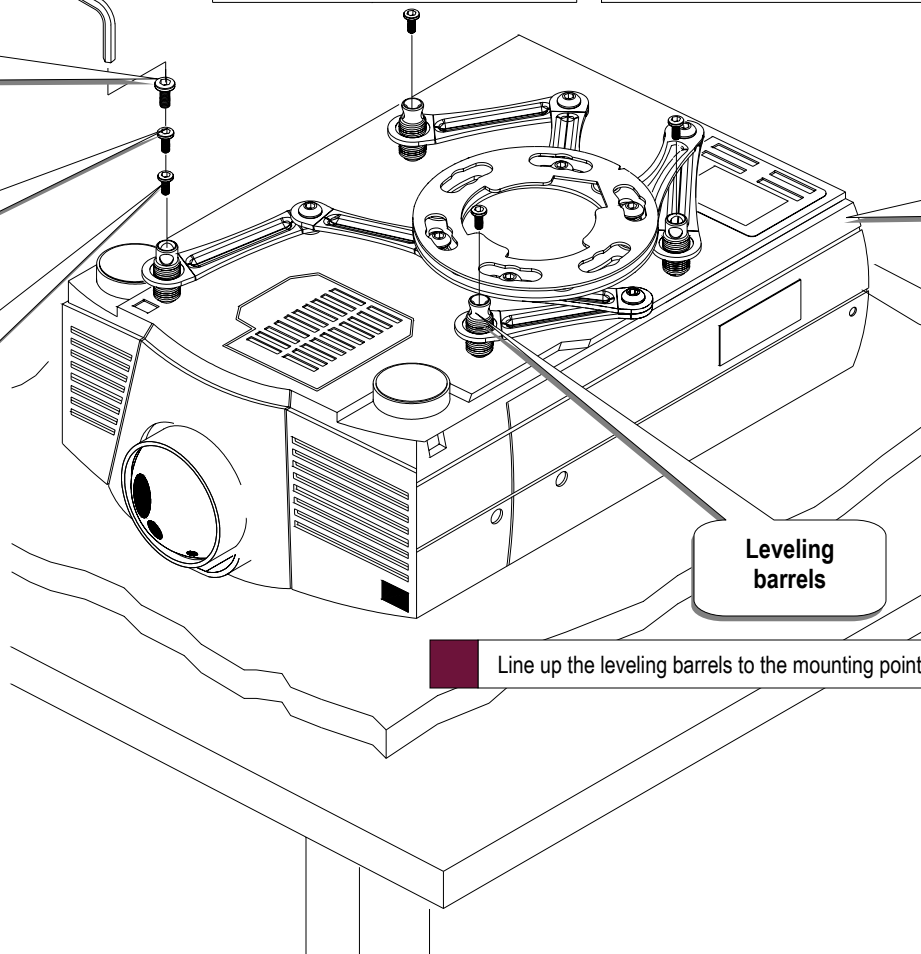
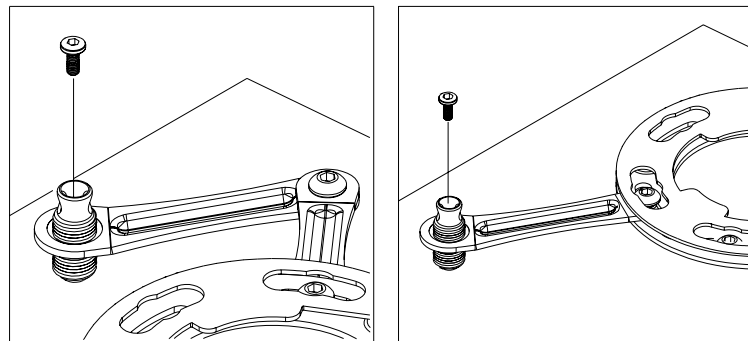

## Leveling the mounting bracket

### Step 4

Rotate the leveling barrels to level the mounting bracket next, position the mounting bracket so that it avoids most, if not all, ventilation points (including lamp & filter access doors). When the position desired is achieved tighten the mounting hardware to the projector then tighten the hex head leg screws with the M5 Allen wrench (supplied). See figure 8,9.

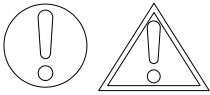

**CAUTION:** Secure but do not over-tighten the mounting hardware. Failure to do so will result in damaging the threads in the projector.

FIGURE 8

M5 Allen wrench

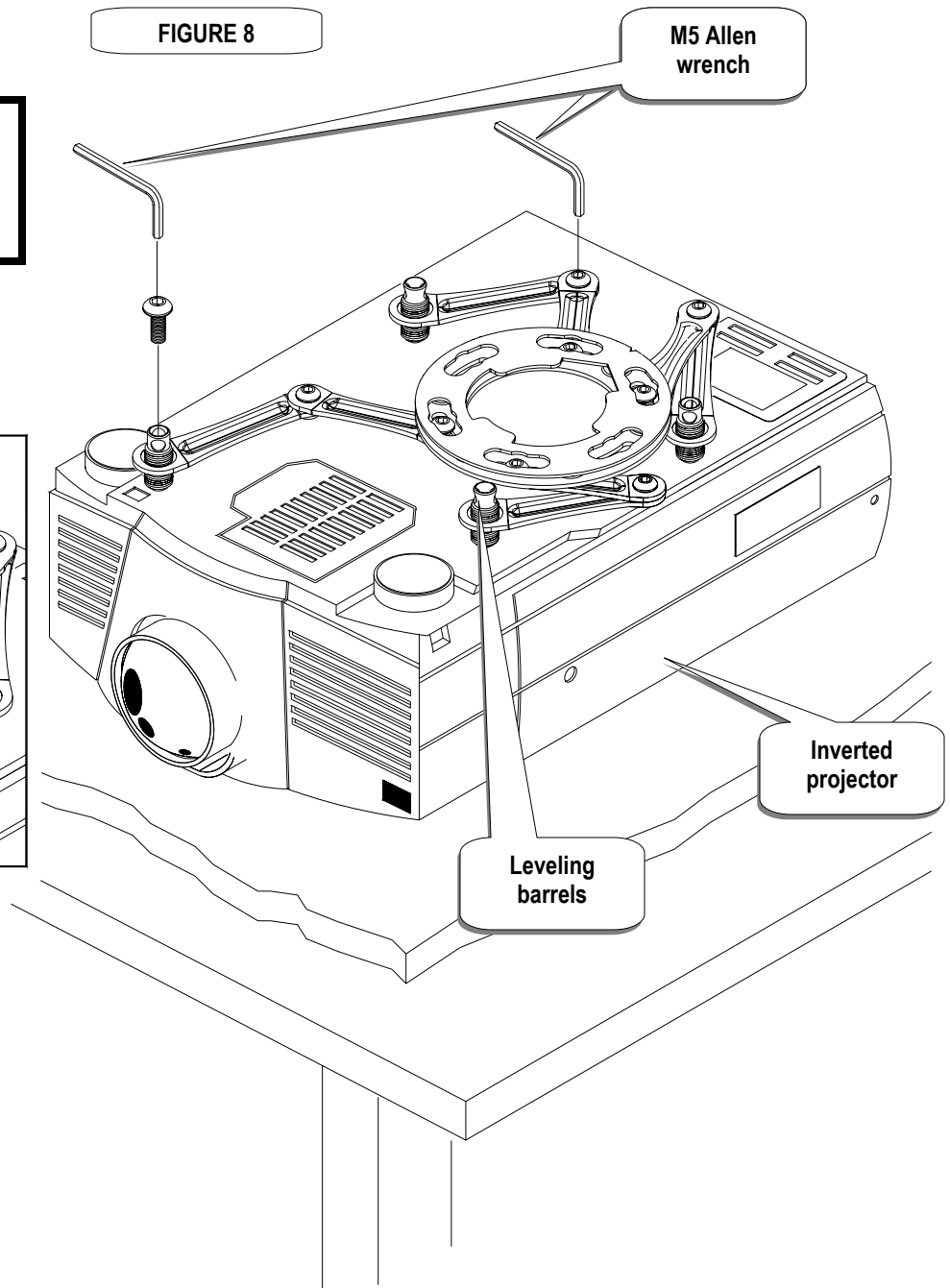
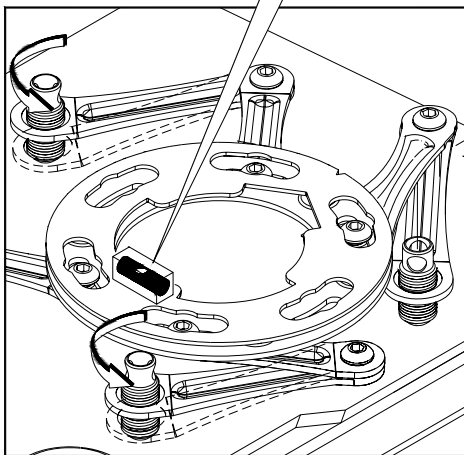
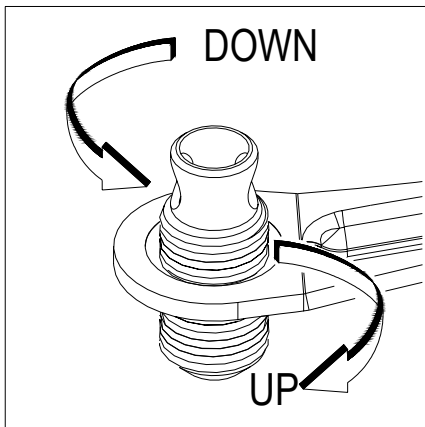

FIGURE 9

Level



DOWN



UP

Adjusting the mount

## Securing the upper assembly ceiling plate

### Step 5

Review your projector's owners manual to determine what distance is recommended from the front of the lens to the edge of the screen for best picture ratio. (**NOTE: however in most home theater and office ceiling mount installations this is not practical as the projector would be too low within the room. At a minimum you should at least locate the inverted projector's top of the lens point to a point centered horizontally on the screen and no higher than the top image edge of the screen**). Most projector manufacturers prefer to have the center of the projector lens centered of the top of the screen when the projector is inverted for ceiling mounting. It is normally better to have the top edge of the lens as close to parallel with the top image edge of the screen as well. Before you mount your screen and projector, make sure the mounting location will safely support the weight of the projector. (see warning on page 3).

**NOTE: Make sure to measure from the center of the mounting bracket to the front edge of the lens to determine the proper placement of the center of the upper assembly.**

Secure the ceiling assembly into a solid wood ceiling stud with the three (3) #14 x 2" wood screws (supplied) or with other (commercially available) hardware depending on your installation environment. **See figure 10.**

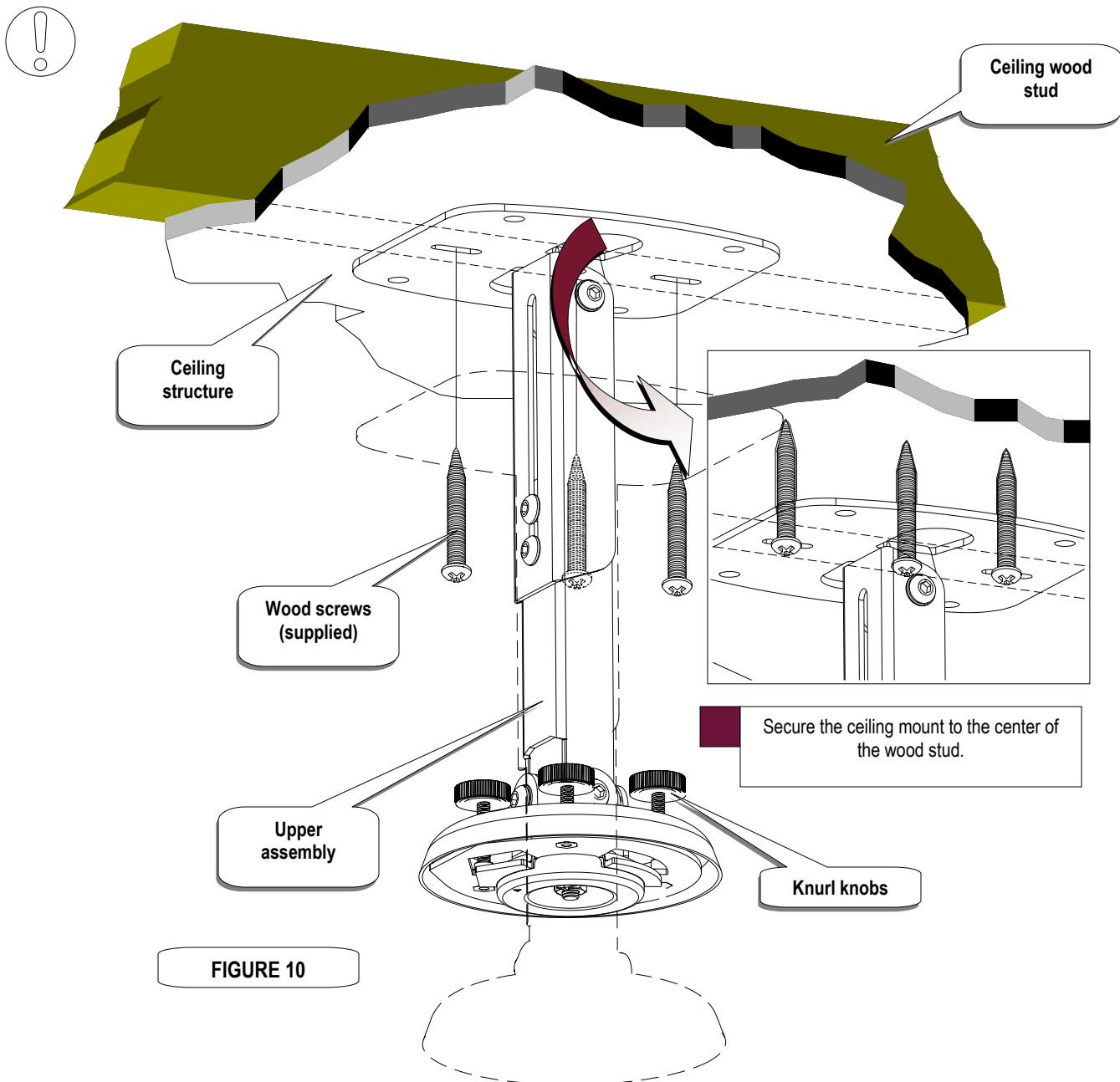

## Low-profile installation

### OPTIONAL

If your installation requires the overall height of the mount to be less than the approximate 9" shown with the standard mount assembly, you can convert the height to only 2 1/2" by simply removing the adjustment channel as shown. Once the extension channel is removed, attach the upper ceiling plate to the ceiling. Once attached install the bell housing assembly to the upper ceiling plate as shown. See figure 11, 12, 13.

### Removing the middle height extension

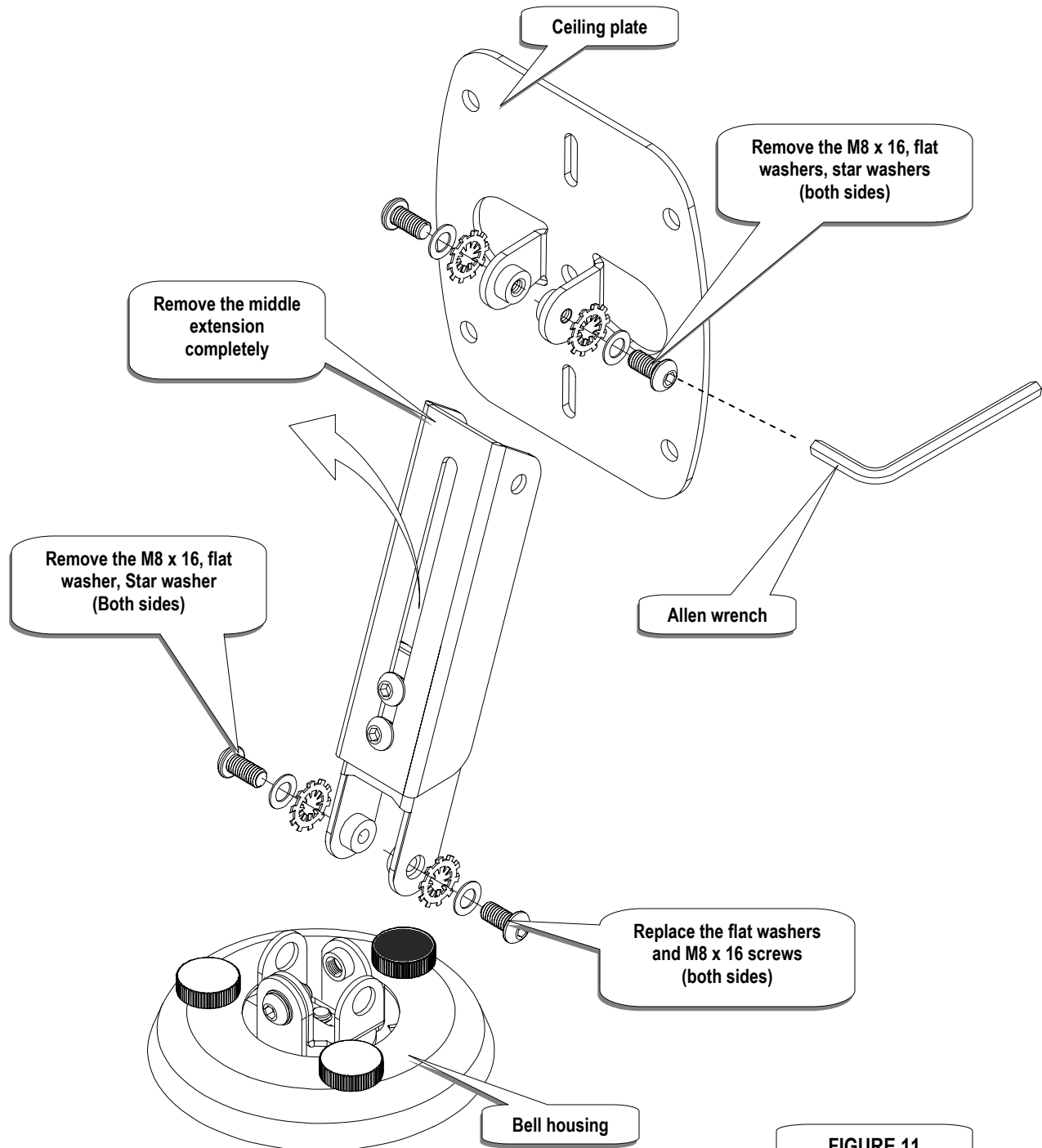
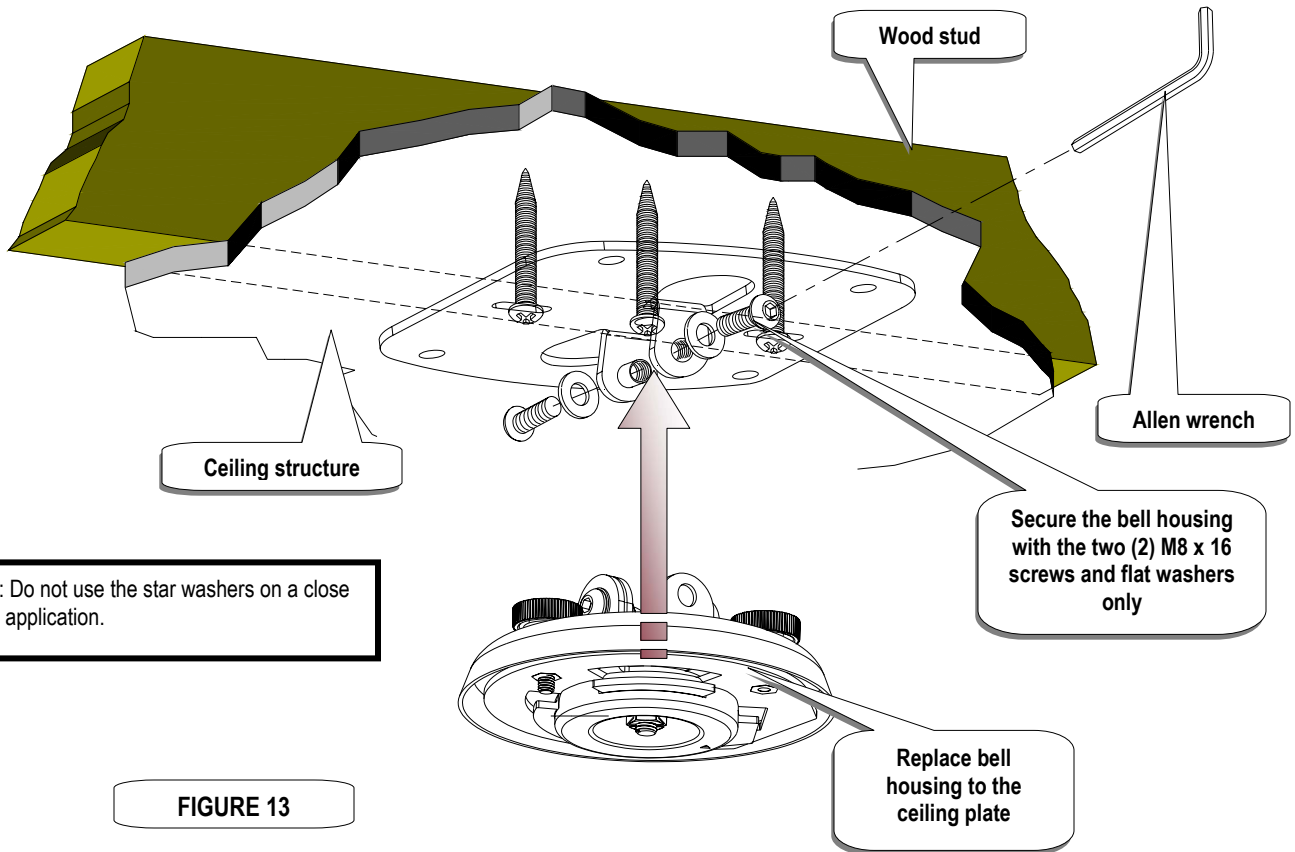
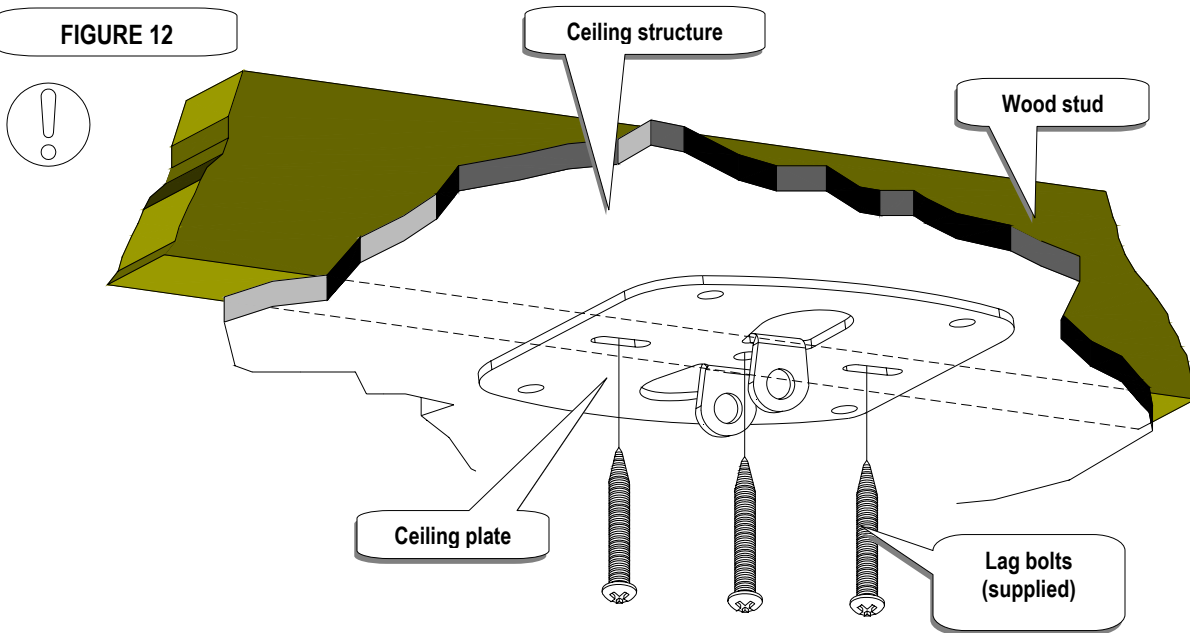

FIGURE 11

Please follow instruction on Step 5 (page 11) in this manual.

**Secure the ceiling plate to the ceiling structure**

**FIGURE 12**



**NOTE:** Do not use the star washers on a close ceiling application.

**FIGURE 13**

## Securing the projector to the upper assembly

### Step 6

Make sure the three knurl knobs are loosened to fully expose to the "tri-lock" mounting plate in the base of the upper assembly. Carefully lift the projector and insert the mounting bracket mating special tri-lock cutout into the mating portion of the upper assembly. Once inserted rotate the projector and mounting bracket 180° and secure the rear safety knob first to prevent further rotation of the bracket in the upper assembly. Tighten the remaining two tension knurl knobs until the mount becomes rigid. The safety knob should line up with the alignment slot on the mounting bracket.

See figure 14

**NOTE:** Follow the number sequence prior to securing the projector to the upper assembly.

FIGURE 14

The alignment slot must be in direct alignment with the safety knob to lock the mounting bracket to the upper assembly.

3

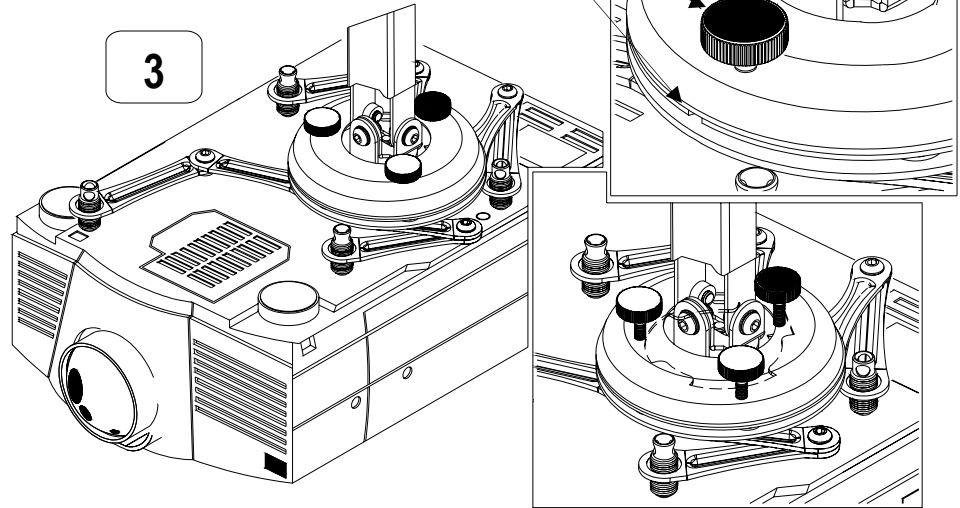

2

Insert universal bracket to the tri-lock, then rotate the projector 180°

Safety knurl knob

Tension knurl knobs

Universal mount

1

Projector

Tri-lock opening

Alignment slot

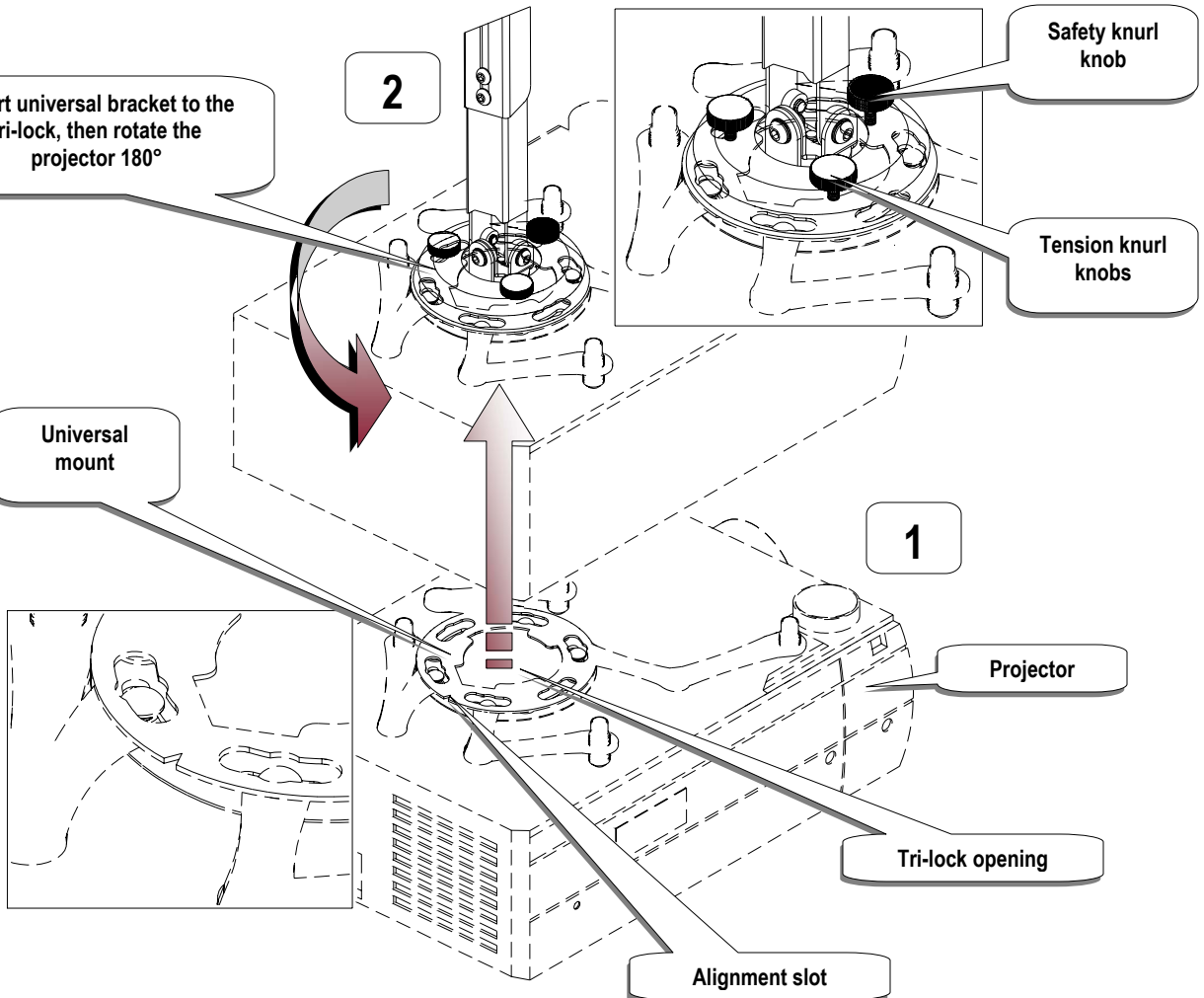
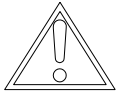

## Final line up adjustments

### Step 7

With the projector secured in the mount and power on and signal supplied to the projector you can now proceed with the final height, tilt and yaw to optimize the projected image.

#### A

The height can be adjusted by slightly loosening the two 8mm height adjustment screws and raising or lowering the projector. Once the height is achieved tighten the two screws.

#### B

To adjust the tilt angle of the projector, slightly loosen the side M8 screws and tilt to the desired angle to the screen and firmly tighten the two M8 tilt adjustment screws.

#### C

If roll adjustment is needed to square the images on the screen, slightly loosen the front and rear M8 screws and adjust to the desired angle then firmly tighten the two M8 roll adjustment screws.

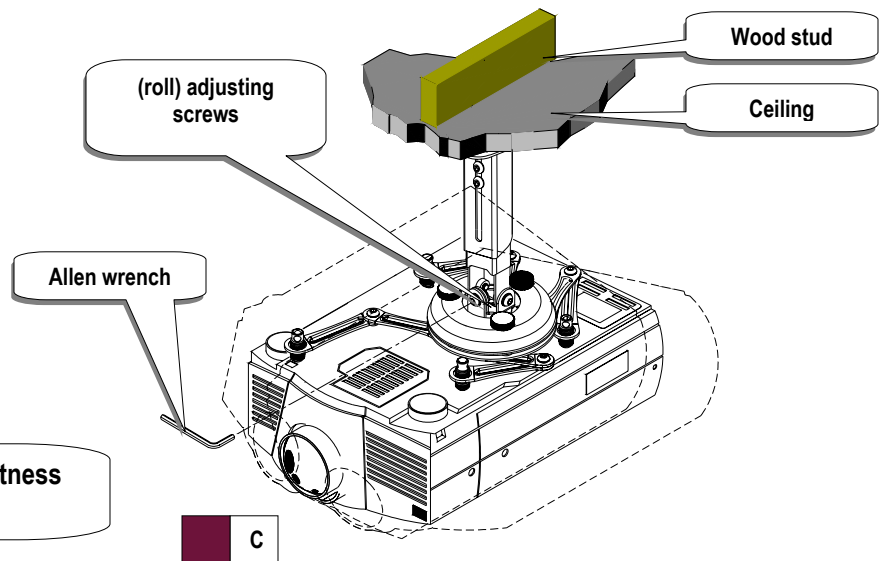
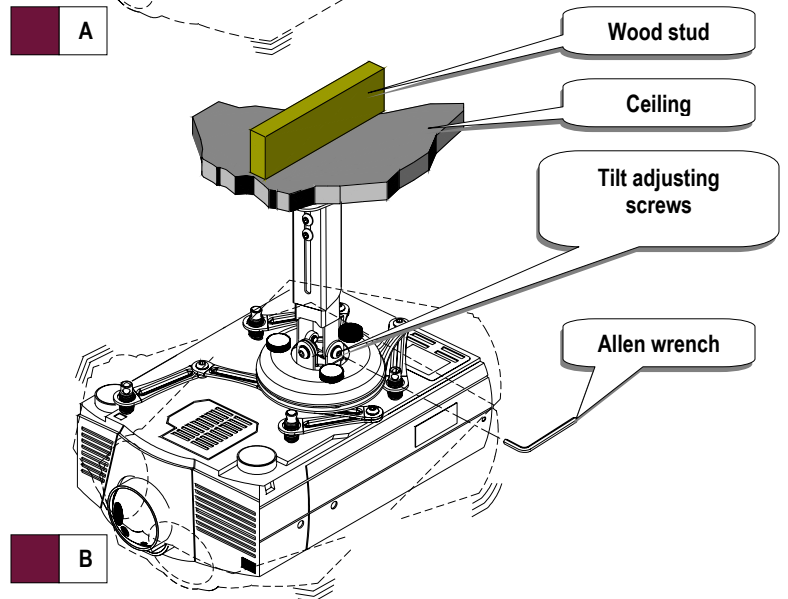
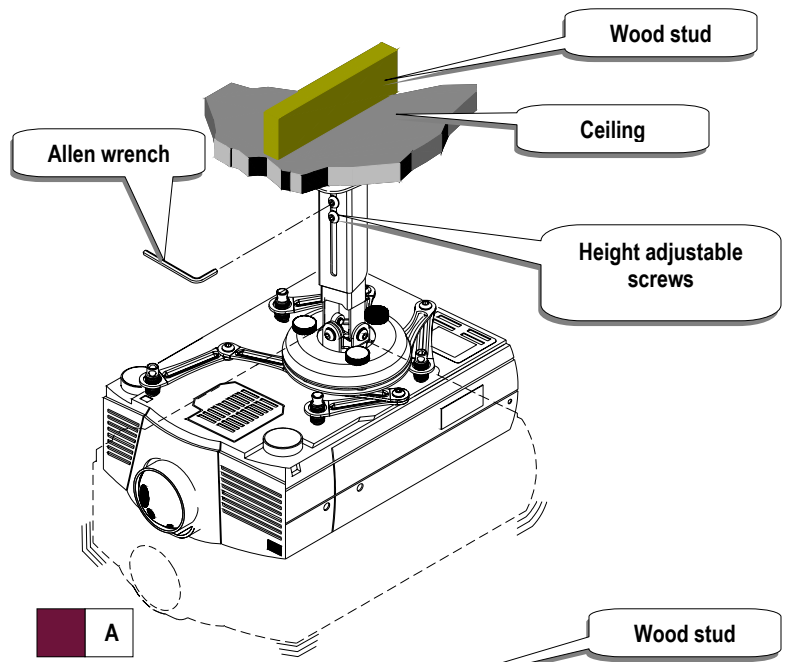

**Re-check hardware for proper tightness and security**



## Installing the plastic caps

### Step 8

Once all the final adjustments have been done, install the plastic caps on the leveling barrels. **See figure 15**

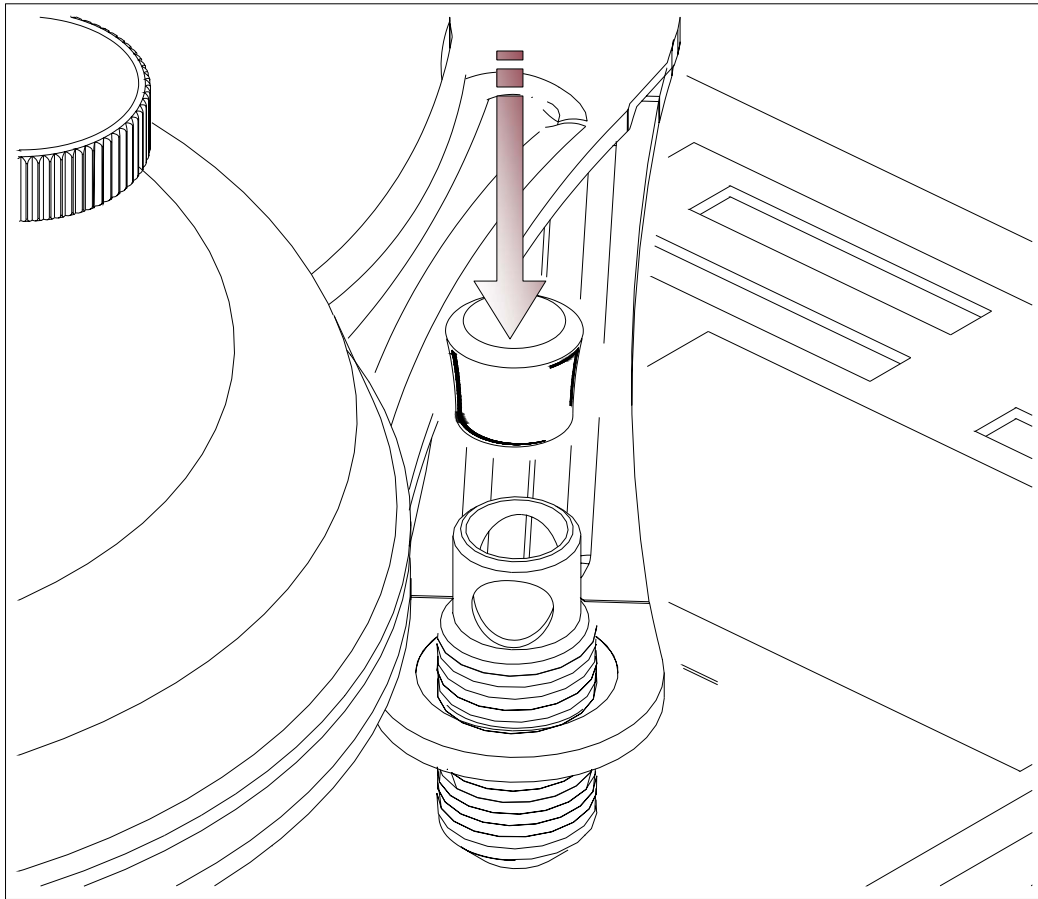

FIGURE 15