

Infinx SCM™ Pro Ceiling Mount.

Professional Mounting Solution designed for quick installation into any standard suspended ceiling.

Everything You Need.

Designed to make every installation a breeze, the Recordex Infinx SCM kit includes everything you need to complete a professional, efficient, installation of nearly any inverted video projector into a standard suspended ceiling grid. The kit includes one universal mount (500UCM) with a 6" extension column (500C06), and one suspended ceiling tray (500SCT) complete with all required installation hardware, and a satin metal finishing ring. The entire kit is finished in décor friendly white. An optional plenum box is available.

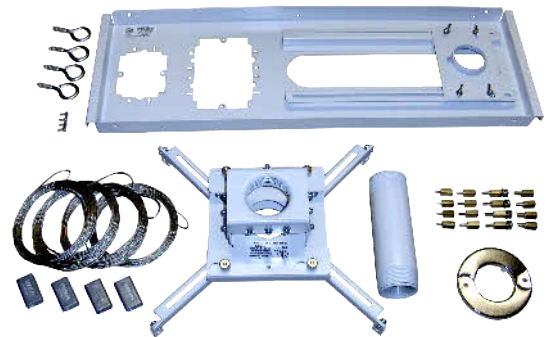

Infinx 500SCT Ceiling Mount Tray

The 500SCT provides for a clean, safe, and efficient way to install a video projector mount from a suspended ceiling grid by way of a 1.5" NPT extension column. The 500SCT is safe, lightweight, and designed for ease of install. Works with all standard ceilings, including 2' x 2' and 2' x 4' grids, in Mexico, Canada, Europe, and the US.

Infinx 500UCM Universal Ceiling Mount

The 500UCM by Recordex offers clean, efficient installation of virtually any inverted projector on the market. The mount ships with four sets of industry standard mounting hardware to guarantee a match regardless of your projector brand. The décor friendly white finish will ensure a professional looking installation and the ten year manufacturer warranty will give you peace of mind. Rated for projectors weighing less than 50 pounds and certified for conformance to UL Standard 1678. Perfect for boardrooms, classroom, and houses of worship.

Infinx 500C06 Extension Column

The 6" x 1.5" NPT extension column allows for quick and easy connection of the universal mount and the ceiling tray. The column is hollow and extends the cable channel of the mount all the way to above the ceiling for simple, clean cable management.

Lots of Warranty At No Extra Charge.

Our 10-year warranty backs up our commitment to quality with extra peace of mind at no extra charge.



205 Westwood Ave, Long Branch, NJ 07740

Phone: 866-94 BOARDS (26273) / (732)-222-1511 | Fax: (732)-222-7088

E-mail: sales@touchboards.com | Site: www.touchboards.com

Features & Specs for 500SCT (Ceiling Tray)

- Installs above the ceiling to allow use of existing ceiling tile for clean professional look.
- Virtually no assembly required, and easy over-the-rail design allows for easy positioning and clamping to the ceiling grid.
- Ships with necessary safety cables, installation hardware, and a satin metal finishing ring.
- Tool free positioning of the extension column socket, and knockouts for single and double gang electrical boxes.
- Designed to work with our plenum box for additional fire safety protection for non-plenum rated cables and accessories.
- Rated for projectors up to 50 pounds.

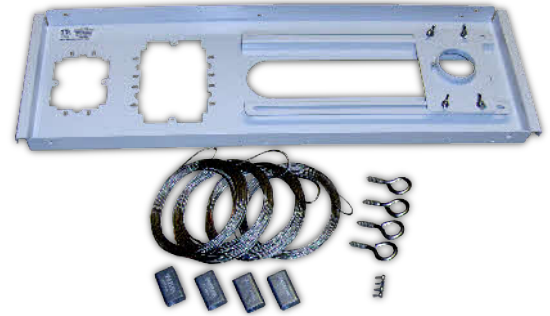

- Rated Weight Load: 50 pounds
- Color: White
- Dimensions (HxWxD): 0.875" x 8.0" x 24.5"
- Weight: 6.6 pounds
- Certifications: Conforms to UL Standard

Features & Specs for 500UCM (Ceiling Mount)

- Equipped with Universal Mounting Bracket
- Spider-style mounting arms include height adjustable stand-off feet
- Projector easily disconnects from mount with 4 thumb screws for easy maintenance and bulb replacement without disturbing the yaw, pitch or roll adjustments.
- Installed with standard 1.5" NPT extension column
- Cables can be easily snaked through 1.85" cable channel
- Décor friendly white finish for a professional clean looking installation
- Tested to meet UL Standard 1678

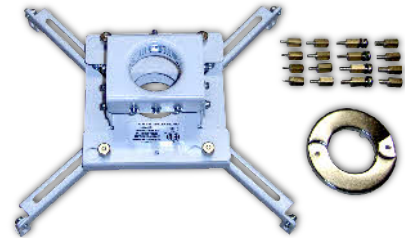

- Rated Weight Load: 50 pounds
- Color: White
- Dimensions (HxWxD): 3.0" x 5.5" x 5.5"
- Weight: 4.4 pounds
- Roll: ±12°
- Pitch: ±19°
- Yaw: 360°
- Certifications: Conforms to UL Standard

Features & Specs for 500UCM (Ceiling Mount)

- Hollow column for routing cables out of sight
- Painted in our décor friendly white finish

- Color: White
- Dimensions: 6" L, 1.5" NPT Diam.
- Weight: 0.5 pounds
- Certifications: Conforms to UL Standard 1678 (ETL 3173417) 1678



Infinix 500PLB-Optional Plenum Box

The 500PLB is an optional accessory for the Infinix SCM mount kit. The 500PLB provides plenum-rated enclosure protection for cables and equipment housed above the mount.

- Large hinged door at top of box for easy access
- Knockouts for .75", 1.0" and 1.5" conduit connections
- Designed for easy relocation of mount without need to remove plenum box (safety cables can pass through plenum sides)

- Color: White
- Dimensions (HxWxD): 5.125" x 7.75" x 13.25"
- Weight: 2.2 pounds
- Knockouts: (2) .75", (4) 1.0", (4) 1.5"
- Certifications: Conforms to UL Standard 1678 (ETL 3173417)



205 Westwood Ave, Long Branch, NJ 07740
 Phone: 866-94 BOARDS (26273) / (732)-222-1511 | Fax: (732)-222-7088
 E-mail: sales@touchboards.com | Site: www.touchboards.com