



# CopyCam

## Form + Function



### Increase Your Productivity in an Instant

Ideal for highly collaborative workers, CopyCam® Image Capturing System changes an ordinary whiteboard into a copyboard, enabling instant capture of notes or drawings.

CopyCam's user-friendly and one-touch process saves time, eliminates the problem of recalling meeting content, and increases productivity in the workplace. Meeting participants simply take notes and sketch the way they would on any standard whiteboard; no pre-planning or computer is required. When ready to capture notes or drawings from the whiteboard, pushing one of three buttons on the control pad instantly saves the image to an internal archive on the LAN, saves to a portable USB drive, or prints to a networked printer.

### Single Button Simplicity

Capturing spontaneous ideas is easy with CopyCam E Image Capturing System. CopyCam E offers the same benefits as CopyCam Pro, with a streamlined (one-button) control panel. When ready to save your notes to the archive, just press one button to capture in full color.



CopyCam E  
Image Capturing System



CopyCam Image Capturing  
System with USB

### Features

- Saves notes and sketches in four colors from any whiteboard
- Prints to a network printer (included with CopyCam)
- Saves to an internal archive on your local area network (LAN)
- Saves to USB flash memory storage to take notes with you
- Instantly emails notes or images to all meeting attendees by integrating RoomWizard™ with your CopyCam system. This is called One-Click Publishing™
- Enables you to attach flipcharts or other handwritten material to the whiteboard and capture them along with the notes written on the board
- Optional one-button format for save-to-web only
- Tracks image and note captures with automatic date and time stamp

### Benefits

- Intuitive and easy to use
- Enables spontaneous collaboration with no pre-planning
- Increases efficiency by eliminating note-taking and administrative follow up
- Provides instantly accessible and portable information for multiple users
- Ideal for highly collaborative groups and teams in the workplace or classroom

## RoomWizard and One-Click Publishing

Adding the RoomWizard Room Scheduling System (RW 10) and One-Click Publishing to CopyCam enables you to automatically email notes to meeting attendees in three simple steps:

1. Use RoomWizard to schedule your meeting time and location, and to invite attendees.
2. Create and capture notes and sketches with CopyCam.
3. With the touch of a button, RoomWizard compiles meeting notes and automatically emails them to each attendee. Notes appear the same as they did in the meeting, enabling retention of contextual memory and promoting more efficient meeting follow-up.

Integrating RoomWizard with CopyCam's note-capturing technology enables you to easily pick up where you left off and move forward in your next meeting.



RoomWizard Room Scheduling System



One-Click-Publishing Note Capture

## Companion Premium Whiteboards

CopyCam is compatible with any marker or chalk board up to 48" x 96" (1200mm x 2400). To add cable management capability and a stylish, environmentally-friendly whiteboard, combine CopyCam with a PolyVision Premium Whiteboard featuring *e<sup>3</sup> environmental ceramicsteel™*. *e<sup>3</sup>*™ is the first and only ecologically intelligent whiteboard surface to receive Cradle to Cradle™ certification and is PolyVision's fourth generation of ceramicsteel writing surfaces.

Premium Whiteboards complete the CopyCam Image Capturing System—an aesthetic, as well as functional and environmentally responsible addition to your collaborative space. Popular Premium Whiteboards include:

- Edge™ with champagne trim; 4' x 8' (C-ED-M-084-T020)
- Mistic™ with champagne trim; 4' x 8' (C-MIM-M-084-T020)

To add cable management between the whiteboard and the CopyCam control pad, choose a Cable Management Bridge for either the left or right side of the whiteboard.

- 0040071-CG: Right side bridge for CopyCam Pro
- 0040072-CG: Left side bridge for CopyCam Pro
- 0040074-CG: Right side bridge for CopyCam E
- 0040075-CG: Left side bridge for CopyCam E



Mistic Premium Whiteboard



Left Side Bridge for CopyCam Pro

## Mobile Surface Solution: Huddleboard™

Lightweight, portable, and versatile – Huddleboard offers a display surface that can be easily moved to a CopyCam for image capture, then moved away for use elsewhere. Huddleboard, when used with CopyCam, provides flexible and multiple solutions for your working or learning environment.



Huddleboards on a Mobile Easel

# CopyCam

## Technical Specifications

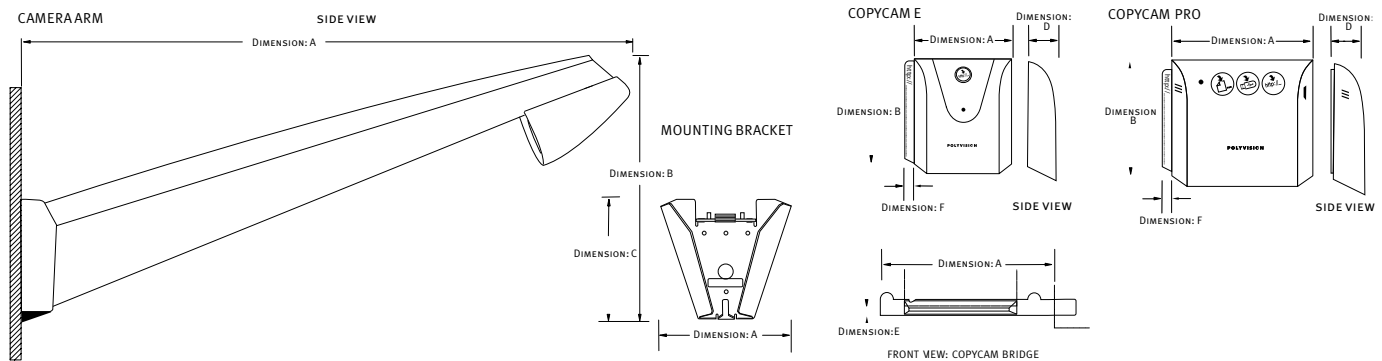

Dimension	CopyCam E	CopyCam Pro	Camera Arm	Mounting Bracket	Control Pad Bridge (E)	Control Pad Bridge (Pro)
A (Width)	4.62" (117.3mm)	7.87" (199.9mm)	38" (965.2mm)	7.5" (190.5mm)	8.62" (218.6mm)	11.87" (301.5mm)
B (Height)	5.75" (146mm)	6.12" (155.4mm)	13.5" (342.9mm)			
C (Bracket Height)				6" (152.4mm)		
D (Depth)	1.62" (41.1mm)	1.75" (44.5mm)				
E					.5" (12.7mm)	.5" (12.7mm)
F	.5" (12.7mm)	.5" (12.7mm)				

### Camera Arm

- 3.5 megapixels resolution
- Captures line drawings and writing in any color
- Enhances contrast for crystal clear copies
- Automatically crops copies to board borders
- Jacks for power, LAN, and control pad

### Control Pad: CopyCam Pro

- 3-button interface allows direct capture to printer, USB, or built-in Web server
- Weighs less than 2 lbs (.75kg)
- Voice prompts and 3-color LED provide status

### Control Pad: CopyCam E

- 1-button interface allows direct capture to web server
- Weighs less than 1 lb (.375kg)
- Voice prompts and 3-color LED provide status

### Printer

- Network-enabled color printer included

### USB Drive

- Writes images to a standard USB drive with Fat12, Fat16, or Fat32 partitions
- Each 10MB of drive space holds approximately 70 images

### Built-in Web Server

- Holds approximately 40 images
- Can be accessed from anywhere on a LAN using standard web browser
- Images are retained if there is power loss
- Supports fixed IP addressing or DHCP protocol

### Power Requirements

100-240VAC, 50-60HZ, 18W  
Energy Star Level IV compliant

### Certification

FCC Class A, UL60950, CSA60950

### Warranty

- One year limited warranty
- Extended warranties available

### Accessories (Included)

- Network-enabled color printer
- User's Guide
- Installation manual
- Mounting templates
- Power adapter with 15' (4.6m) cord
- 15' (4.6m) Ethernet cable
- 10' (3.04m) cable from arm to control pad
- 24' (7.32m) of cable raceway in 4' (1.22m) sections
- "Tilt-up" mounting bracket for camera arm
- 17' (5.1m) power supply extension cable

Simple. Effective. Extraordinary.  
The way communication should be.

**Environmental Policy:** PolyVision strives for continuous improvement in all areas of environmental stewardship – responsible use of raw materials and natural resources, design processes and operation of all facilities – to protect, replenish, and restore the communities in which we live and serve.

PolyVision Corporation

1.800.620.POLY

www.polyvision.com

info@polyvision.com

**PolyVision**<sup>®</sup>  
A Steelcase Company