



205 Westwood Ave, Long Branch, NJ 07740

Phone: 866-94 BOARDS (26273) / (732)-222-1511

Fax: (732)-222-7088 | E-mail: sales@touchboards.com

CopyCam™

Installation Guide

www.touchboards.com

205 Westwood Ave.

Long Branch, NJ 07740

1-866-942-6273

Sales@touchboards.com

Information in this document is subject to change without notice.
Reproduction in any manner without written permission of PolyVision Corporation is forbidden.

PolyVision Corporation reserves the right to make changes in product design, or detail, and to discontinue any product or material without notice.

CopyCam is a trademark of PolyVision Corporation, a Steelcase Company.

The Bluetooth trademarks are owned by Bluetooth SIG, Inc., USA.

Table of Contents

Overview	3
What Comes in the Box	4
Spatial Requirements	6
Mounting the Control Pad and Camera Arm	7
Planning for Wiring	7
Mounting CopyCam Against the Wall	8
Preparing to Install the Control Pad	8
Installing the Control Pad Mounting Plate	8
Routing the Control Pad Cable	11
Locking the Control Pad in Place	12
Removing the Control Pad From its Mounting Plate	13
Preparing to Install the Camera Arm	14
Installing the Camera Arm Mounting Plate	14
Cable Routing and Connections in the Camera Arm	17
Locking the Camera Arm in Place	19
Concealing Cables	20
Routing Cables Within the Wall	20
Installing and Testing the Printer	23
About the Color Printer...	23
Installing the Printer	23
Testing the Printer	24
Evaluating the Test Copy	24
Calibrating CopyCam	25
When to Calibrate CopyCam	25
How to Calibrate CopyCam	25
Materials	25
Calibrating CopyCam	26
Web Configuration and Testing	29
CopyCam Web Server Introduction	29
Configuring the CopyCam Web Server	29

Troubleshooting	33
Voice Status Messages	35
Technical Support	36
FCC Compliance	36
CE Declaration of Conformity	37
Warranty	38

OVERVIEW

Welcome to CopyCam™, your quick and easy tool to capture information from a whiteboard or chalkboard. CopyCam converts existing whiteboards and chalkboards into electronic copyboards. The user works on the board as usual, then presses one of three buttons to print, save to disk, or save to the web.

This manual provides instructions for installing CopyCam. Refer to the *CopyCam User Guide* for help using CopyCam.

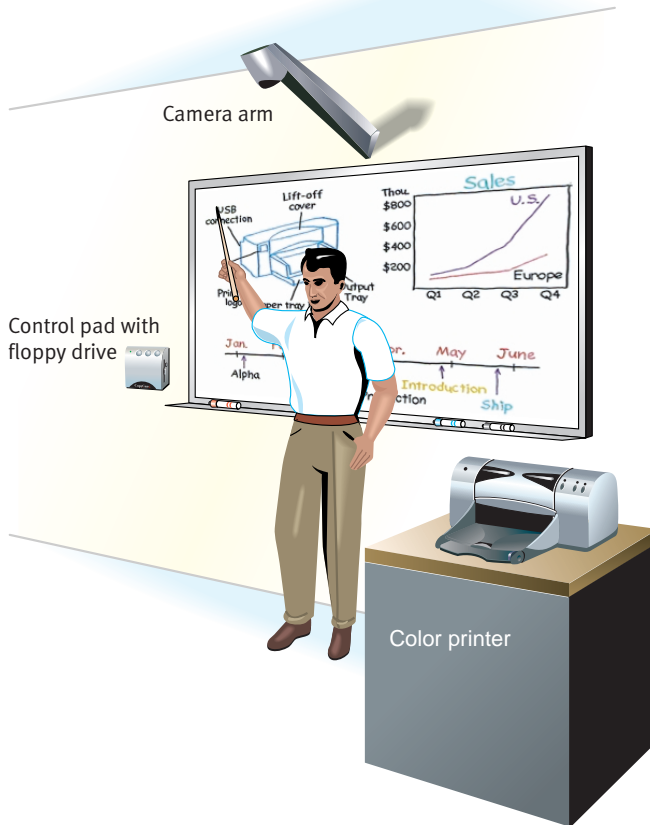

WHAT COMES IN THE BOX

- 1 camera arm
- 2 camera arm mounting plate
- 3 control pad
- 4 control pad mounting plate
- 5 color printer with power cable and two starter ink cartridges
- 6 Bluetooth wireless printer adapter*
- 7 ethernet cable
- 8 power adapter and cord
- 9 camera arm positioning template
- 10 control pad positioning template
- 11 five 4' (1200mm) sections of cable raceway (for concealing cables)
- 12 two cable raceway tees
- 13 four cable raceway elbows
- 14 six calibration sheets (four corner sheets, one whiteboard, one blackboard sheet)
- 15 four border buttons
- 16 four #8 x 1.5" (38mm) drywall screws
- 17 seven toggle bolts
- 18 seven toggle bolt screws (10-24 x 1.25" [32mm])
- 19 two arm-securing thumb screws
- 20 eight wing nuts
- 21 Installation Guide (this guide)
- 22 User Guide
- 23 web server configuration CD-ROM
- 24 registration card
- 25 roll adhesive tape

NOTE:

**Your CopyCam includes either a printer already enabled for Bluetooth wireless communication, or a standard color printer and a Bluetooth wireless adapter. Both printer configurations work identically and print at the same speed.*

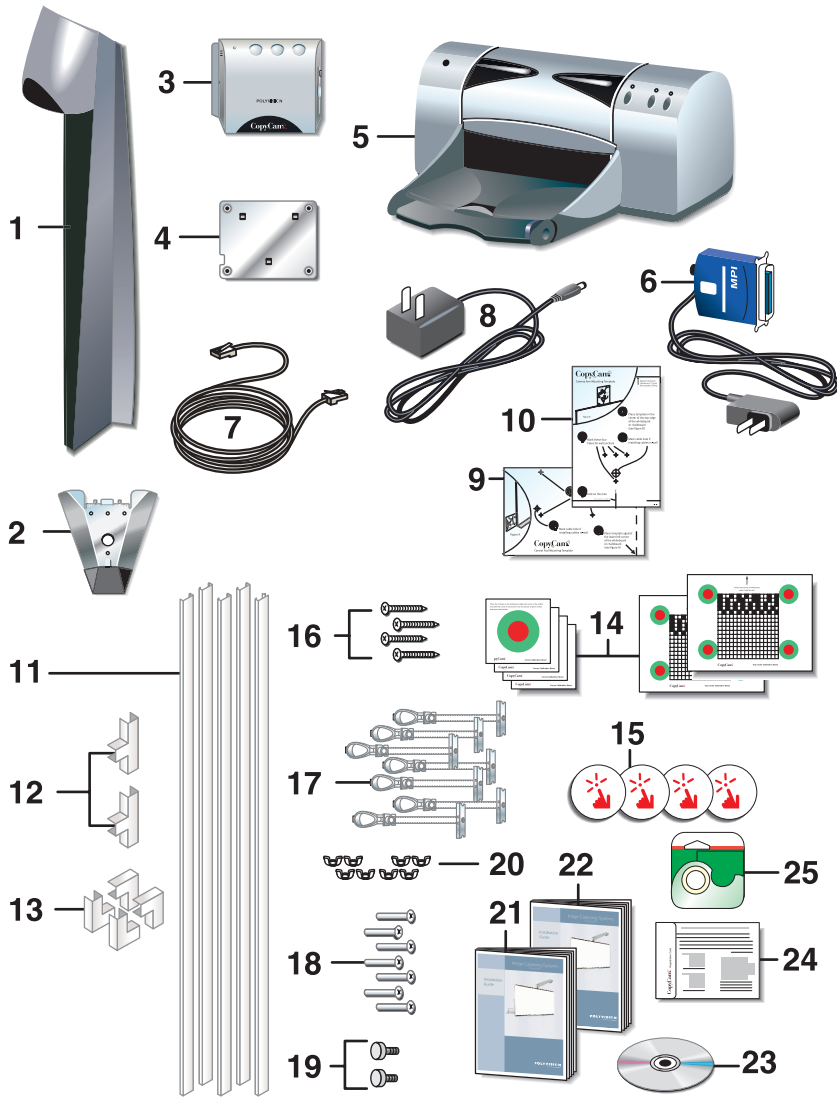

SPATIAL REQUIREMENTS

CopyCam components use space above the board and to the left of the board.

WARNING

A minimum of 14.1" (360mm) above the board is required for installation of the camera arm, as shown below. If you do not have at least 14.1" (360mm) of clearance, do not attempt to install CopyCam. Consider the possibility of moving your board down, or, with a false ceiling, of raising the ceiling.

Remove projection screens, maps or other devices above the board that can interfere with the camera arm position.

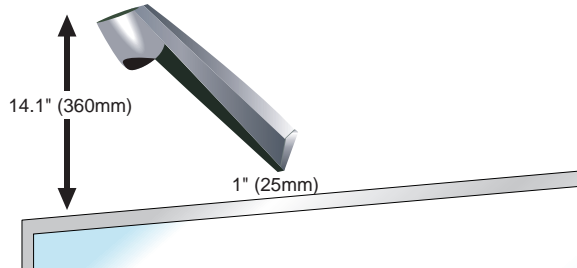

The control pad includes a floppy diskette drive that the user accesses from the right. The preferred location for the control pad is four inches (100mm) to the left of the board, and about five inches (120mm) above the bottom of the board, as shown below.

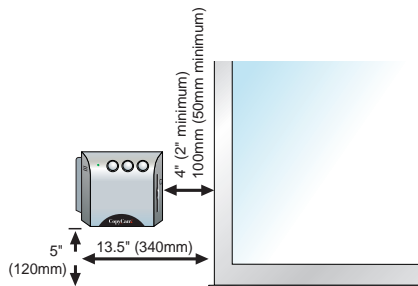

MOUNTING THE CONTROL PAD AND CAMERA ARM

Expect to spend about two hours on this installation.

PLANNING FOR WIRING

CopyCam has three cable connections that converge in the camera arm, as shown below.

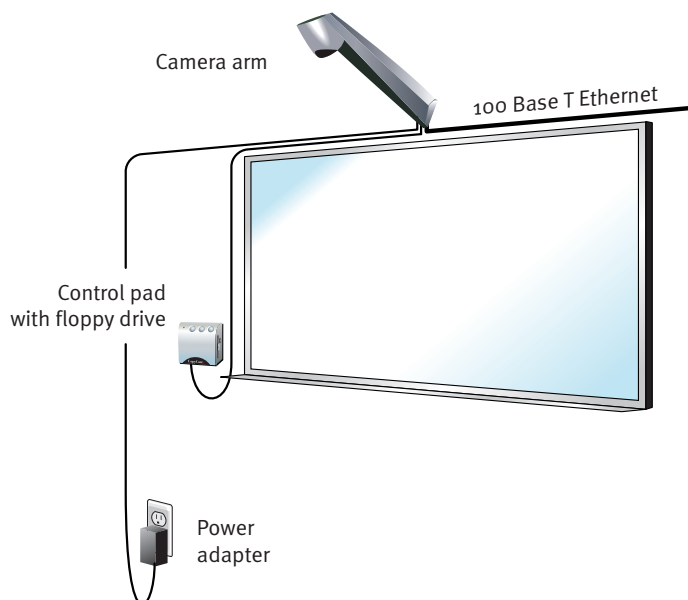

CopyCam wiring can be either:

- against a wall, the typical approach for adapting an existing facility, or
- within a wall, a potential for new construction or renovation

NOTE:

Use the positioning templates provided to assure proper location of the control pad and camera arm. Failure to do so may result in inhibited access to the floppy disk drive in the control pad, or in incomplete copies of the board.

MOUNTING COPYCAM AGAINST THE WALL

Instructions below provide details for routing cables against the wall. Refer to “Routing Cables Within the Wall” on page 21 for differences when installing cables within a wall.

Preparing to Install the Control Pad

WARNING

You must fasten the brackets to the wall so they are secure. CopyCam mounts to any kind of wall construction. Instructions and wall fasteners are provided to help you install CopyCam when walls have metal or wood studs. Be sure to locate studs and use them to drive mounting screws whenever possible.

Locate and have ready to use:

- control pad positioning template
- control pad
- control pad mounting plate
- two #8 x 1.5" (38mm) drywall screws (provided)
- four toggle bolts (provided)
- four toggle bolt screws (provided)
- power drill with 1/2" (12mm) bit
- power screwdriver with phillips bit, or phillips screwdriver
- pencil
- tape measure (optional)

Installing the Control Pad Mounting Plate

These instructions guide you through installing CopyCam on a sheetrock wall. If your wall material is some other substance, such as concrete or brick, use these instructions as a guideline but install appropriate anchors to secure the unit to the wall.

To position the control pad mounting plate:

- 1 Punch holes in the control pad positioning template at the locations of the four screws.
- 2 Fold the control pad positioning template along the dotted line to form a shelf, as shown.

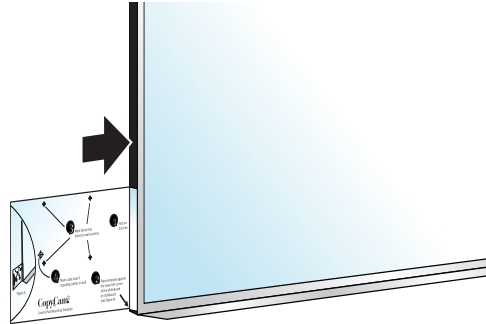

- 3 Position the folded control pad positioning template on the LEFT BOTTOM edge of the board, as shown. This indicates the ideal position and the minimum distance from the board.
- 4 If possible, locate a metal or wooden stud that is nearest this position.
- 5 Mark the four screw hole positions on the wall using an awl, a pencil, or marker so that at least one fastener will attach to the stud, if possible.
- 6 Remove the template.

To install the control pad mounting plate:

- 1 At positions that do NOT align with a stud, drill 1/2" (12mm) holes at the marked positions, using caution not to make the holes too large, and install a toggle bolt (provided) at each position as follows:
 - a Tilt the metal piece so it is flat against the long axis of the two plastic cords and push it through the 1/2" (12mm) hole, as shown below.

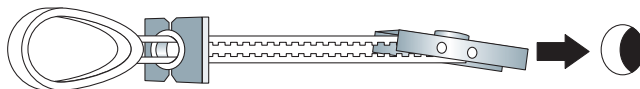

- b Pull back on the toggle bolt to pull the metal piece tight against the interior of the wall.
- c Slide the plastic cap tight against the exterior of the wall.

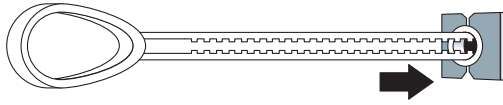

- d Snap off the finger hold and plastic cords flush with the wall.

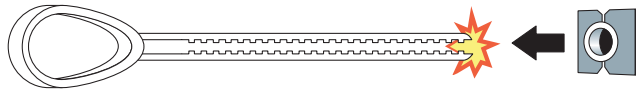

- 2 Position the control pad mounting plate over the 4 mounting holes with the tabs pointing up, as shown below.

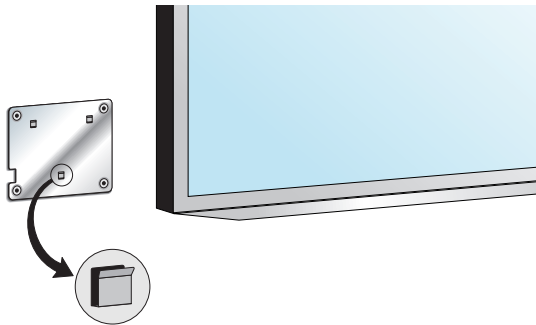

- 3 Drive the toggle bolt screws (provided) through the mounting plate and toggle bolt, and if a stud was located, drive a #8 x 1.5" (38mm) drywall screw (provided) through the mounting plate and wall into the stud.

NOTE:

The control pad mounting plate has feet that hold it slightly away from the wall.

Routing the Control Pad Cable

The control pad has one cable:

- RJ14 cable to the camera arm

The cable grommet at the back of the control pad allows for routing the cable against the wall or through the wall. The cable is configured at the factory for routing against the wall or behind a writing surface, as shown below. For routing cables within the wall, refer to “Routing Cables Within the Wall” on page 21.

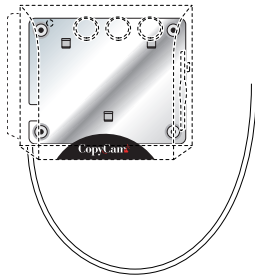

Allow the cable to hang from beneath the control pad until you are ready to route it to the camera arm.

Locking the Control Pad in Place

The control pad slides down onto its mounting plate and snaps into place.

To lock the control pad in place:

- 1 Lower the control pad onto the tabs on the mounting plate, as shown. The control pad will snap into place.

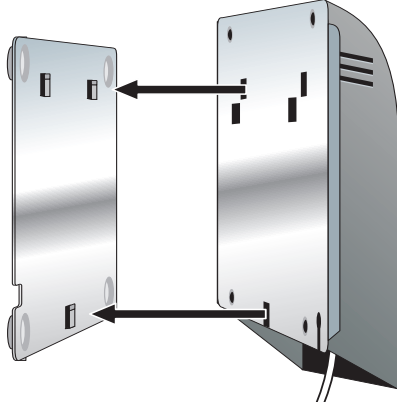

Removing the Control Pad From its Mounting Plate

If you want to remove the control pad from the mounting plate:

- 1 Locate the release latch at the bottom of the control pad, as shown.

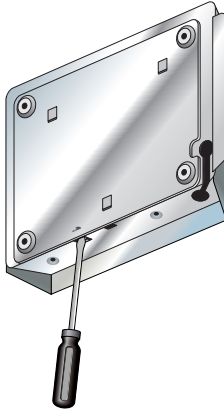

- 2 Gently press up on the release latch with a small, flat blade screwdriver until the latch releases.
- 3 Slide the control pad up off the mounting plate.

Preparing to Install the Camera Arm

WARNING

You must fasten the brackets to the wall so they are secure. CopyCam mounts to any kind of wall construction. Instructions and wall fasteners are provided to help you install CopyCam when walls have metal or wood studs. Be sure to locate studs and use them to drive mounting screws if possible.

Locate and have ready to use:

- camera arm positioning template
- camera arm
- camera arm mounting plate
- two #8 x 1.5" (38mm) drywall screws (provided)
- three toggle bolt screws (provided)
- two camera arm-securing thumb screws (provided)
- eight wing nuts (provided)
- power drill with 1/2" (12mm) bit
- power screwdriver with phillips bit or phillips screwdriver
- pencil
- tape measure
- ladder

Installing the Camera Arm Mounting Plate

These instructions guide you through installing CopyCam on a sheetrock wall. If your wall material is some other substance, such as concrete or brick, use these instructions as a guideline but install appropriate anchors to secure the unit to the wall.

Install the camera arm mounting plate one inch (25mm) above the board.

NOTE:

The position of the camera arm is critical to the proper function of the CopyCam lens and camera. Use the camera arm positioning template during installation to ensure that the camera will properly focus on the full board (up to 4' x 8' [1200mm x 2400mm]). Refer to "Spatial Requirements" on page 6.

To position the camera arm mounting plate:

- 1 Measure and mark the top center of the horizontal dimension of the board or imaging area.
- 2 Locate metal or wooden studs in the wall nearest that location.

- 3 Punch holes in the template at the positions of the four screw holes.
- 4 Fold the camera arm template along the dotted line to form a shelf, as shown.

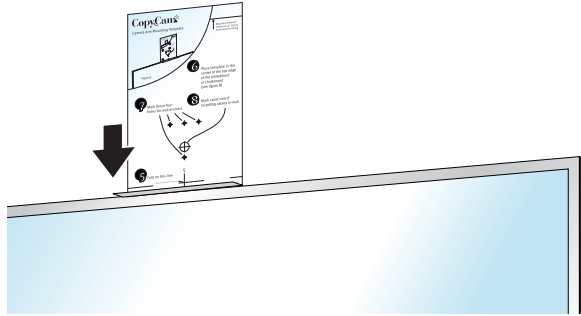

- 5 Rest the folded camera arm positioning template on the top edge of the board, aligning the center line with the center line of your board.
- 6 Mark the four screw hole positions using an awl, a pencil, or marker.
- 7 Remove the template. Note if any of the screw positions align with a stud.

To install the camera arm mounting plate:

NOTE:

Three toggle bolts are included for installation of the camera arm. Use the outside three holes if you must use toggle bolts.

- 1 At positions that do NOT align with a stud, drill 1/2" (12mm) holes at the marked positions, using caution not to make the holes too large, and install a toggle bolt (provided) at each position as follows:
 - a Tilt the metal piece so it is flat against the long axis of the two plastic cords and push it through the 1/2" (12mm) hole.

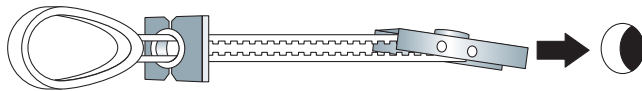

- b Pull back on the toggle bolt to hold the metal piece tight against the interior of the wall.
- c Slide the plastic cap tight against the exterior of the wall.

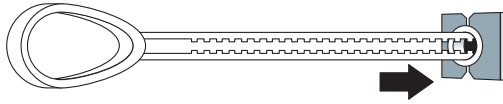

- d Snap off the finger hold and plastic cords flush with the wall.

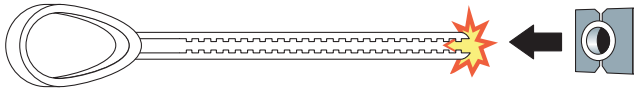

- 2 Position the camera arm mounting plate over the mounting holes.

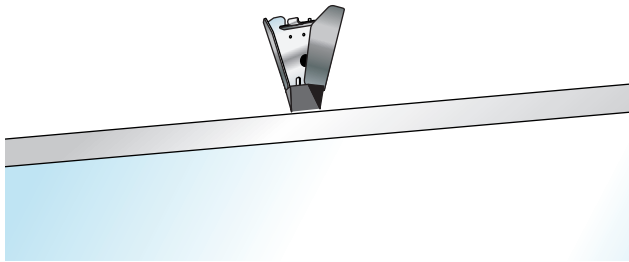

- 3 Drive the toggle bolt screws (provided) through the mounting plate and toggle bolt, and if a stud was located, drive a #8 x 1.5" (38mm) drywall screw (provided) through the mounting plate and wall into the stud.

Cable Routing and Connections in the Camera Arm

As illustrated in the section titled “Planning for Wiring” on page 7, the camera arm has three cable connections:

- RJ45 ethernet cable to Local Area Network (LAN) (optional)
- RJ14 cable from control pad
- power from power adapter

The camera arm allows for routing cables against the wall or through the wall. For routing cables within the wall, refer to “Routing Cables Within the Wall” on page 21.

To connect cables in the camera arm:

- 1 Hang the camera arm from the hook at the bottom of the mounting plate, as shown below.
- 2 Locate the cable ends and route them through the exit holes in the end of the camera arm and up to the cable connectors. Cable exit holes are available on either side of the camera arm.

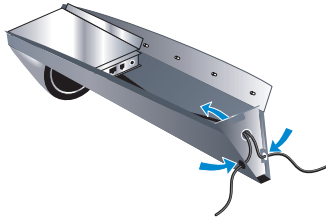

- 3 Plug cables into the cable connectors in the camera arm, as shown below.

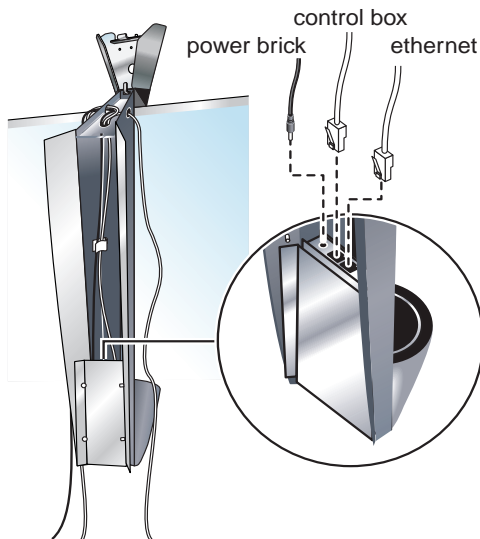

- 4 Secure the cables to the body of the camera arm (for strain relief) using the cable ties inside the arm.

- 5 Secure the camera arm cover using the eight wing nuts provided. Note that the narrow end of the camera arm lid should be closest to the top of the arm.



Locking the Camera Arm in Place

The camera arm tilts up and locks into position for fastening with two screws (provided).

To lock the camera arm in place:

- 1 Determine if there is excess cable, and if there is, push it into the camera arm cavity through the exit hole at the end of the arm.
- 2 Tilt up the arm, lifting it slightly so that it slides over the pins on the top of the mounting plate. It should support its own weight at this point. Be sure cables are not pinched between the arm and the mounting plate.

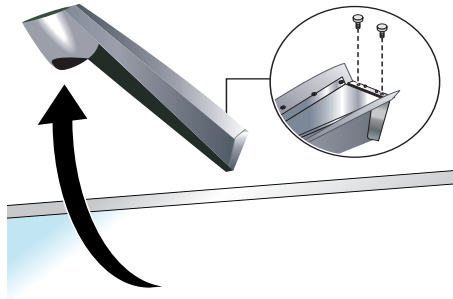

- 3 Fasten the arm in place using the two arm-securing thumb screws provided.

Concealing Cables

A cable raceway is provided to conceal cables along one edge of the board.

To conceal cables:

- 1 Route cables tightly against the edge of the board.
- 2 Conceal cables using the cable raceway, elbows, and couplers provided.
- 3 If necessary, stow any excess cable in the camera arm cavity by removing the camera arm cover and pulling cable through the exit hole.

This completes the installation of CopyCam built-in components. Turn to page 23 to install the printer.

ROUTING CABLES WITHIN THE WALL

If you are routing CopyCam cables within the walls, the instructions for mounting the control pad and camera arm differ in the sequence that you perform steps. Refer to instructions provided in “Mounting the Control Pad and Camera Arm” on page 7, but proceed in the following sequence:

- 1 Position the control pad and camera arm positioning templates. Refer to “To position the control pad mounting plate:” on page 9 and “To position the camera arm mounting plate:” on page 14.
- 2 Mark the wall anchor positions and the cable exit hole positions on the wall.
- 3 Drill holes and, ideally, add conduit within the wall to route the RJ14 cable between the control pad and the camera arm mounting plate exit holes. (Boxes are not recommended.)
- 4 Drill a hole in the wall for the power cord to exit near an outlet.
- 5 Install the control pad mounting plate and camera arm mounting plate. Refer to “To install the control pad mounting plate:” on page 9 and “To install the camera arm mounting plate:” on page 15.
- 6 On the back of the control pad, compress the rubber cable grommet and slide it up so the RJ14 cable exits toward the wall instead of toward the floor.

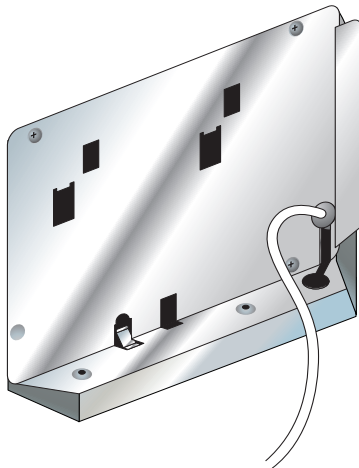

- 7 Route the RJ14 cable from the back of the control pad into the wall and up to the camera arm mounting plate exit hole. If necessary use a

fish tape to fish the cable end through the wall to the camera arm mounting plate exit hole.

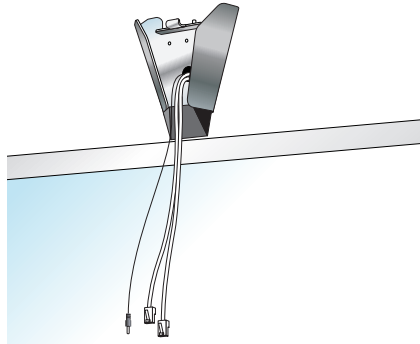

- 8 Leave about 24 inches (500mm) of cable extending from the camera arm mounting plate exit hole for later connection to the camera arm, as shown.
- 9 Mount the control pad to its mounting plate. Refer to “Locking the Control Pad in Place” on page 12.
- 10 Route power and optional ethernet cables to the camera arm mounting plate exit hole.
- 11 Hang the camera arm from the hook on the mounting plate as pictured on page 18.
- 12 Route the cables through the center cable exit hole of the camera arm.
- 13 Connect the three cables in the camera arm and cable tie the cables in the cavity of the camera arm. Refer to “Cable Routing and Connections in the Camera Arm” on page 17.
- 14 Place the camera arm cover over the camera arm and secure using the eight wing nuts provided.
- 15 Tilt up and lock the camera arm in place, using the two arm-securing thumb screws provided. Refer to “Locking the Camera Arm in Place” on page 20.

INSTALLING AND TESTING THE PRINTER

ABOUT THE COLOR PRINTER...

Each CopyCam includes a color printer. The printer is either a Bluetooth™ wireless printer or a printer with a Bluetooth wireless adapter. The CopyCam camera arm is configured at the factory to transmit a radio signal to the Bluetooth adapter or wireless printer that comes in the same box.

Bluetooth technology allows the printer to receive its signal anywhere in a 30 feet (10m) radius from the camera arm. The printer can be placed in a separate room if desired, although walls may slightly reduce the signal range. If you need to install a replacement printer, refer to the *CopyCam User Guide*.

INSTALLING THE PRINTER

To install the printer:

- 1 Identify a location for the printer within 30 feet (10m) of the CopyCam camera arm and within a few feet (one meter) of a power outlet.
- 2 If included, plug the Bluetooth adapter into the printer and plug in the adapter's power cord.

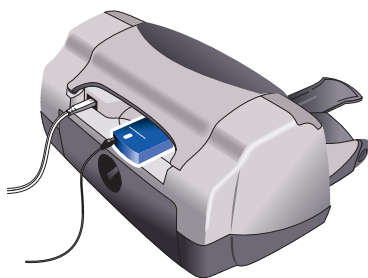

- 3 Plug in the printer's power cord.
- 4 If it is not already on, power on the printer.
- 5 Add ink cartridges (provided with the printer).
- 6 Add paper.

TESTING THE PRINTER

NOTE:

If you have a blackboard (or any board that is not white), you need to calibrate CopyCam so it can detect the edges of the board. Before testing the printer, follow the steps in “Calibrating CopyCam” on page 25.

To test the printer and the CopyCam installation:

- 1 Turn on the printer and confirm that it has paper and ink cartridges.
- 2 Write something on the board.
- 3 Press the  button on the control pad. The voice prompt says “captured” and the printer starts printing within one minute.

Evaluating the Test Copy

CopyCam is designed to capture writing and line drawings in color under a variety of lighting conditions. Part of its function is to enhance the contrast to produce a sharp image every time. It automatically crops copies to the borders of the board, or to an area of up to 4' x 8' (1200mm x 2400mm).

The first copy you make will establish the borders of the board. If the voice prompt reports “calibration needed,” CopyCam was unable to detect the borders. Refer to “Calibrating CopyCam” on page 25 for instructions. If the test copy never appears or results in other concerns, refer to “Troubleshooting” on page 33.

NOTE:

Your first use of CopyCam includes an automatic calibration. This calibration crops the bottom two inches (50mm) of the board image to eliminate the glare along the bottom edge caused by the eraser tray found on most boards. If you want to include the bottom two inches (50mm) of your board in captures, you will need to calibrate CopyCam using the procedure described below.

CALIBRATING COPYCAM

WHEN TO CALIBRATE COPYCAM

Calibration is necessary in only about ten percent of CopyCam whiteboard installations. Blackboards (or any board that is not white) always require calibration.

Conditions that are likely to require calibration include:

- boards without easily discernible borders
- CopyCam mounted above an area with no borders
- CopyCam mounted to a board that is greater than 8' (2400mm) long or 4' (1200mm) high

You need to calibrate when:

- you have a blackboard (or any board that is not white)
- images are distorted
- the voice prompt (from the control pad) reports "calibration needed"

HOW TO CALIBRATE COPYCAM

Calibrating CopyCam involves showing it the corners of your board (or 4' x 8' [1200mm x 2400mm] limit) using five of the six calibration sheets provided.

Materials

Locate and have ready to use:

- tape measure
- adhesive tape (provided)
- six calibration sheets (provided)

NOTE:

If you cannot locate your calibration sheets, you can download them from the PolyVision web site at: <http://www.websterboards.com>. You will need a color printer to print these sheets.

Calibrating CopyCam

To calibrate CopyCam:

- 1 Measure an area 4' x 8' (1200mm x 2400mm) or less, with the top centered at least one inch (25mm) below the camera arm, as shown.

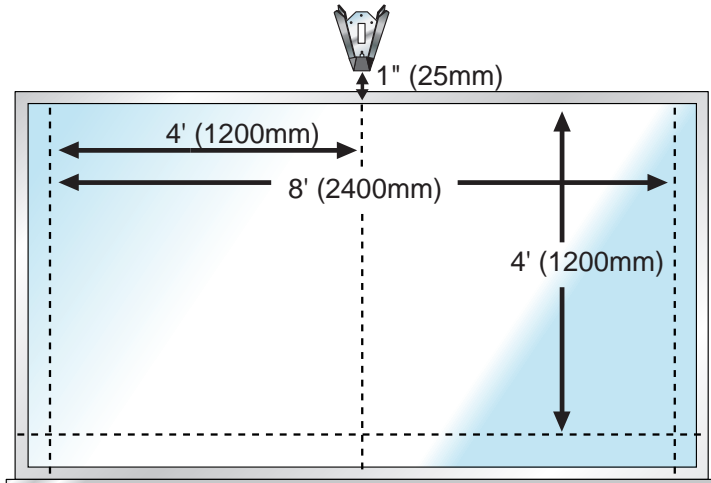

- 2 Position the four corner calibration sheets within the 4' x 8' (1200mm x 2400mm) limit as shown below. If your board is 4' x 8' (1200mm x 2400mm) or less, put the four matching calibrations sheets in the corners.

NOTE:

To attach the sheets to the board, use low gloss tape or put tape on the BACK of each sheet. Be sure that all four corners are taped securely.

- 3 Choose one of the two larger calibration sheets based on the type of board: whiteboard or blackboard (or any other dark-colored board). The calibration sheets are clearly labeled. Position this fifth calibration sheet at the top center of the board, as shown below.

If your board is 4' x 8' (1200mm x 2400mm) or smaller, place the sheets in the corners.

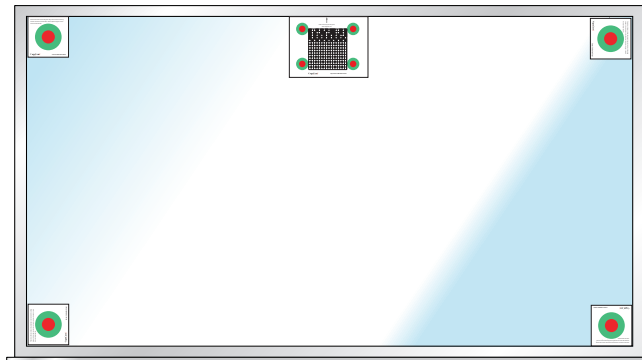

If your board is larger than 4' x 8' (1200mm x 2400mm), place the sheets within the 4' x 8' (1200mm x 2400mm) limits.

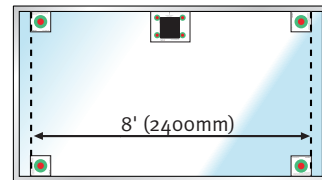

- 4 Press the  button on the control pad. CopyCam recognizes the calibration sheets and performs an internal calibration based on the dimensions specified.
- 5 If your board is wider than 8' (2400mm) or taller than 4' (1200mm), mark the boundary of CopyCam captures by applying the four self-adhesive border buttons provided, as shown below. These buttons remind users what part of the board is captured by CopyCam.

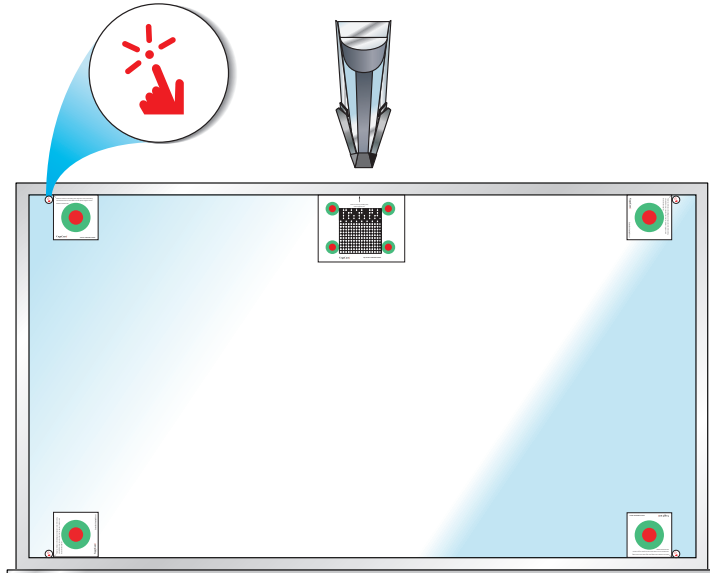

- 6 Remove the calibration sheets and set them aside in a safe place, such as tucked into this manual.

NOTE:

If CopyCam is installed with a blackboard and if white chalk is normally used, or if printing exclusively to a black and white printer such as a network laser printer, consider setting CopyCam to capture in monochrome to optimize capture quality. Refer to "Using the Settings Tab" in the CopyCam User's Guide for information about capturing in color and monochrome.

WEB CONFIGURATION AND TESTING

COPYCAM WEB SERVER INTRODUCTION

CopyCam can save copies to the internal web server located in the camera arm. Users access copies over a Local Area Network (LAN) using any web browser.

Using CopyCam's web server is optional. However, to change CopyCam's advanced settings, you must access the CopyCam web server.

Although CopyCam does not require installing software on any computer, a web page is provided on the PolyVision web site to help you locate the CopyCam IP address(es) on your Local Area Network.

If you misplace the CopyCam configuration CD-ROM, configuring the CopyCam web server requires Internet access to the PolyVision web site from a computer participating in the same LAN as the CopyCam installation. Find the CopyCam web server configuration page under "CopyCam" at <http://www.websterboards.com>.

CONFIGURING THE COPYCAM WEB SERVER

Multiple CopyCam systems may be installed on the same LAN. Your LAN can use DHCP or fixed IP protocols. DHCP allows CopyCam to obtain its LAN address automatically. If you are unsure of whether to use DHCP, check with your system administrator.

If your LAN uses DHCP, CopyCam initiates its own configuration when you power on the system. CopyCam asks the network for an available IP address and assigns it to itself. If, instead, your LAN uses fixed IP addresses, CopyCam listens on the ethernet network and performs "IP address squatting" to assign itself a temporary IP address. In order for you to learn the IP address it has acquired, you need access to a web page that you open from the PolyVision web site.

To configure CopyCam:

- 1 On a computer connected to the same LAN and subnet as the CopyCam installation, insert the CopyCam installation CD-ROM.
- 2 Double-click the "setup" file.
- 3 Click "Start" to locate all CopyCams on your LAN and display their IP addresses.

NOTE:

If no CopyCams appear, close the window and once again double-click the “setup” file. (CopyCam performs IP address squatting only after the first time you click “Start.”)

- 4 Click the IP address link to the CopyCam web page. The CopyCam web page appears, as shown.

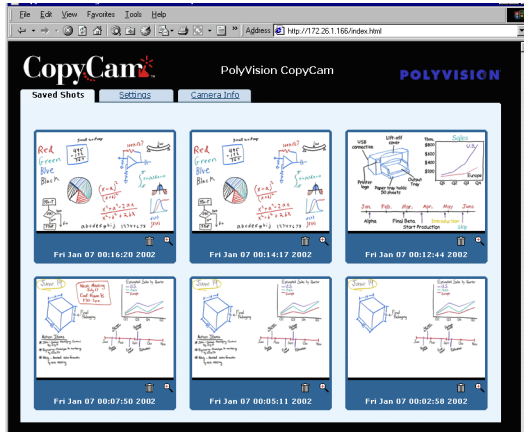

- 5 If you have more than one CopyCam, verify that you have linked to the correct web server by saving a copy to the web:
 - a Go to the board and write something unique.
 - b Press the  button.
 - c Wait one minute.
 - d Return to the computer.
 - e Click the Refresh button on your browser.
 - f Confirm that the copy appears on the web page.
- 6 In your web browser, add the CopyCam web site to Favorites or create a shortcut. (In most browsers, you can drag the address to a “Links” area, and the browser will create a shortcut for you.) Rename the shortcut so CopyCam is easier to identify.

- 7 Click the “Settings” tab on the CopyCam web site. In the “Settings” tab, you can see and change the IP address, and other valuable information, as shown. (Refer to the *CopyCam User Guide* for a description of each item in the “Settings” tab.)

Screenshot of the CopyCam Settings page. The "Settings" tab is selected. The page shows various configuration options:

- Use DHCP
- IP address : 192.168.1.20
- Subnet Mask : 255.255.255.0
- Gateway : 192.168.1.1
- Board Name : Main Conference Room
- Capture Type : Monochrome Color
- Printer Type : Bluetooth Ethernet
- Bluetooth Printer Channel : 00:03:6E:10:1E:C4-6
- Ethernet Printer Address :
- Control Pad Volume : Medium Soft
- Date/Time : June 20, 2002 1:59:22 PM
- Low Light Warning
- Firmware Update Server : default
- New Password :
- Confirm Password :
-

NOTE:

If your LAN does not support DHCP (uses fixed IP addressing), you MUST change the temporary IP address to a permanent one that your system administrator assigns. If your LAN uses DHCP, your system administrator may want you to assign a permanent IP address, but it is not usually required. If it is not required, go to step 9.

- 8 If you must change the IP address, proceed as follows:
 - a Click the checkbox beside “Use DHCP” to remove the check.

- b Change the IP address to a permanent IP address that has been selected by your system administrator.
- c Click the “Submit Changes” button. Settings are password protected. You see the Password dialog, shown below.



- d Enter your password. The factory default user name is blank and password is “admin.”
 - e Click “OK.”
- 9 Make a note of the IP address for safe keeping.
- 10 Also write the address in the space provided on the control pad, as shown below, so any user can easily browse to the CopyCam web site.







TROUBLESHOOTING

ISSUE	RESOLUTION
The printed copy is unclear, off center, or crooked.	The system may require calibration. Refer to “Calibrating CopyCam” on page 25 for instructions.
Copy quality on a blackboard remains poor after calibration.	<ul style="list-style-type: none"> • Dusty blackboards can reduce contrast for CopyCam. Be sure that your board is cleaned thoroughly before writing. • If color is not important to you, you can dramatically improve contrast by changing capture type from color to monochrome. Refer to “Using the Settings Tab” in the CopyCam User Guide for instructions.
Writing along the bottom edge of the printed copy is unclear or whited out.	Glare from the eraser tray along the bottom edge of the board is interfering with the capture. You may need to change the lighting near your board or calibrate CopyCam with the bottom calibration sheets two inches or so above the bottom of the board. For best results, lighting should not be directly over the board.
CopyCam cannot be located from a browser.	<ul style="list-style-type: none"> • Confirm that the CopyCam configuration has properly obtained the CopyCam address. Try performing the configuration again as described on page 29. • Check the ethernet cable connection in the camera arm. • If the ethernet cable is connected to a hub, confirm that the hub’s link indicator light is on.
When the  button is pressed, the CopyCam voice prompt says “printer problem.”	<ul style="list-style-type: none"> • Confirm that the printer is powered on and loaded with ink and paper. • CopyCam may be unable to find your printer. Move the printer closer to the CopyCam arm. • Check for interfering devices, such as microwave ovens, wireless telephones, and other network devices operating at 2.4 GHz.

<p>No CopyCam systems appear in the list when “Start” is pressed in “setup.html” during configuration.</p>	<ul style="list-style-type: none"> • Confirm that you are configuring the CopyCam web server from a computer that shares the same LAN segment as the CopyCam system. • Double-click “setup.html” again and click “Start” again. CopyCam may be attempting to squat on an address. • Check the ethernet cable connection in the camera arm. • If the ethernet cable is connected to a hub, confirm that the hub’s link indicator light is on. • If an incorrect network address was entered, you may need to reset the system to factory settings, which results in the loss of all settings and stored images. To reset the system: <ol style="list-style-type: none"> 1 Remove the power adapter from the wall for 5 seconds. 2 Plug the power adapter back into the wall. 3 Within 10 seconds of plugging the power adapter back into the wall, press all three control pad buttons simultaneously.
<p>The control pad LED is not lit.</p>	<ul style="list-style-type: none"> • Confirm that the power adapter is properly connected to the wall. • Confirm that the power adapter cable is properly connected in the camera arm. • Confirm that the control pad is properly connected in the camera arm. The larger jack is reserved for the ethernet cable. The control pad cable connector looks similar but is smaller. • Confirm that the power adapter is not on a switched outlet.
<p>The printer sometimes stops in the middle of a printout.</p>	<ul style="list-style-type: none"> • The printer may be too far away. Move the printer closer to the CopyCam arm. • Check for interfering devices, such as microwave ovens, wireless telephones, and other network devices operating at 2.4 GHz.
<p>The password for the Setup tab has been lost or forgotten.</p>	<ul style="list-style-type: none"> • Reset the system to factory settings, which results in the loss of all settings and stored images. To reset the system: <ol style="list-style-type: none"> 1 Remove the power adapter from the wall for 5 seconds. 2 Plug the power adapter back into the wall. 3 Within 10 seconds of plugging the power adapter back into the wall, press all three control pad buttons simultaneously.

VOICE STATUS MESSAGES

Voice messages provide status feedback. The table below is a summary of voice messages.

VOICE MESSAGE	STATUS
"Hello"	Power restored
"One copy", "Two copies", ...	 button pressed
"Another copy"	 button pressed
"Save disk"	 button pressed
"Save web"	 button pressed
"Captured"	Board capture complete
"Ready"	Printing, save to floppy diskette, or save to web complete
"Working"	Please wait while CopyCam writes a floppy diskette or reboots
"Printer problem"	Printer out of paper, printer out of ink, or printer unavailable
"No printer"	Printer is not on-line or could not be found
"Full"	CopyCam cannot capture because the printing buffer is full
"No disk"	Floppy diskette missing
"Problem"	A problem occurred and CopyCam needs to reboot
"Disk full"	Floppy diskette is full
"Web problem"	Web server not responding: contact Technical Support
"Disk problem"	Floppy diskette unformatted or bad
"Low light"	Low light conditions result in longer capture time
"Hardware problem"	Hardware failure: contact Technical Support

"Calibration needed"	Cannot detect borders and calibration has not been performed
"Calibration done"	Calibration is complete and CopyCam is ready for use
"Calibration problem"	Calibration unsuccessful

TECHNICAL SUPPORT

For technical support in the USA, contact PolyVision Corporation at: 888-388-0995 or e-mail us at support@websterboards.com. In other countries, contact your local technical customer service representative and/or your Steelcase dealer. If you require assistance with locating your local Steelcase dealer, contact the PolyVision Business Center at:

Zuiderring 56
3600 Genk, Belgium

Phone: +32 (0)89 32 31 30

Fax: +32 (0)89 32 31 31

E-mail: business.center@polyvision.com

To order CopyCam parts, contact PolyVision Corporation at: 800-334-4922 from inside the USA, or 503-523-2000 from outside the USA

FCC COMPLIANCE

This equipment has been tested and found to comply with the limits for a Class A digital device, pursuant to Part 15 of the FCC Rules. These limits are designed to provide reasonable protection against harmful interference when the equipment is operated in a commercial environment. This equipment generates, uses, and can radiate radio frequency energy and, if not installed and used in accordance with the instruction manual, may cause harmful interference to radio communications. Operation of this equipment in a residential area is likely to cause harmful interference in which case the user will be required to correct the interference at his own expense. Modification of this device in any manner not approved by PolyVision Corporation may void the user's authority to operate it.

CE DECLARATION OF CONFORMITY

Hereby, Polyvision Corporation declares that this Data Transmission Equipment Operating in the 2.4 GHz ISM Band and using Spread Spectrum Modulation Techniques is in compliance with the essential requirements and other relevant provisions of Directive 1999/5/EC.

WARRANTY

PolyVision Corporation warrants to the original end-user purchaser that this product is free from defects in material and workmanship for a period of one year from the date of purchase. During the warranty period, and upon proof of purchase, the product will be repaired or replaced (with the same or similar model) at our option, without charge for either parts or labor. Shipping costs will apply.

Please keep your original sales receipt or delivery invoice for proof of purchase. Without proof of the purchase date, your warranty will be defined as beginning on the date of manufacture, which is recorded by serial number at the factory.

This warranty applies only to the first end-user purchaser and only when the product is used in a country for which it is labeled for sale. Some factory-reconditioned parts may be used in the assembly of this product.

WHAT IS NOT COVERED

- 1 Any product that is sold or used outside of the region for which it was specifically labeled.
- 2 Any product on which the serial number has been defaced, modified, or removed.
- 3 Damage, deterioration, or malfunction resulting from, but not limited to:
 - Accident, misuse, abuse, neglect, fire, water, lightening or other acts of nature, unauthorized product modification, or failure to follow instructions supplied with the product.
 - Use of abrasive cleaning materials on the enclosures or lens.
 - Any damage incurred in shipping.
 - Removal or installation of the product.
 - Excessive weight applied to the product.
 - Failure to mount the product securely in accordance with the written installation instructions.
 - Any other cause that does not relate to a product defect.
- 4 Cartons, carrying cases, or any accessories used in connection with the product.
- 5 Costs of installation and adjustment. These costs are the responsibility of the consumer.
- 6 Shipping charges to and from our factory or authorized repair depot.

HOW TO GET WARRANTY SERVICE

If you experience a problem with this product, contact PolyVision Technical Support (888) 388-0995 in the USA, or your local technical customer service representative and/or your Steelcase dealer to resolve the problem. If the product is diagnosed as being defective, you will be directed to return the product directly to PolyVision and will be provided with a Return Materials Authorization (RMA) number from

PolyVision. All products returned to PolyVision must have an RMA number assigned, regardless of reason for return. The RMA number must be clearly marked on the outside of the shipping carton; any unit without an RMA number will be returned to the sender. In the USA, please call (800) 334-4922 to obtain an RMA number. Once you have a valid RMA number, ship the product, prepaid and insured to:

PolyVision Corporation
14523 SW Millikan Way, Suite 130
Beaverton, OR 97005
USA

Outside the USA, please call +32 (0)89 32 31 30 to obtain an RMA number. Once you have a valid RMA number, ship the product, prepaid and insured to:

PolyVision Business Center
Zuiderring 56
3600 Genk, Belgium

LIMITATION OF DAMAGES AND IMPLIED WARRANTIES

POLYVISION WARRANTS THAT THE PRODUCT WILL OPERATE SUBSTANTIALLY IN CONFORMITY TO THE POLYVISION DOCUMENTATION AND PUBLISHED SPECIFICATIONS FOR A PERIOD OF ONE YEAR AFTER CONSUMER PURCHASE, PROVIDED IT IS USED IN ACCORDANCE WITH POLYVISION'S USER INSTRUCTIONS. POLYVISION'S SOLE AND EXCLUSIVE LIABILITY, AND YOUR EXCLUSIVE REMEDY, FOR ANY BREACH OF THIS WARRANTY IS THAT, IF THE BREACH IS REPORTED TO POLYVISION IN WRITING WITHIN THE ONE-YEAR WARRANTY PERIOD, POLYVISION WILL CORRECT THE NONCONFORMITY, EITHER BY CORRECTING THE PRODUCT OR (WHERE APPROPRIATE) DOCUMENTATION; REPLACING THE PRODUCT; OR, WHERE POLYVISION DETERMINES THAT CORRECTION OR REPLACEMENT IS NOT FEASIBLE, REFUNDING THE FEE ACTUALLY PAID FOR THE PRODUCT. NO OTHER REMEDY SHALL BE AVAILABLE TO YOU.

EXCEPT AS EXPRESSLY SET FORTH HEREIN, POLYVISION MAKES NO WARRANTY OF ANY KIND, EXPRESSED OR IMPLIED. POLYVISION DISCLAIMS ANY IMPLIED WARRANTY OF MERCHANTABILITY OR FITNESS FOR A PARTICULAR PURPOSE.

POLYVISION SHALL HAVE NO LIABILITY BEYOND THE OBLIGATIONS SET FORTH ABOVE. IN NO EVENT SHALL POLYVISION BE LIABLE FOR ANY INDIRECT DAMAGES, WHETHER INCIDENTAL, CONSEQUENTIAL, OR OTHERWISE (AND EXPRESSLY INCLUDING LOST PROFITS AND LOSS OF DATA) OR FOR ANY DAMAGES IN EXCESS OF THE PURCHASE PRICE OF THIS PRODUCT UNDER THIS OR RELATED AGREEMENTS, WHICH DAMAGES ARISE OUT OF THE USE OF THE HARDWARE, IRRESPECTIVE OF WHETHER POLYVISION SHALL HAVE BEEN INFORMED OF THE POSSIBILITY OF SUCH DAMAGES AND IRRESPECTIVE OF THE CAUSE OF DAMAGE, INCLUDING NEGLIGENCE. SOME STATES RESTRICT THE RIGHT TO EXCLUDE CERTAIN WARRANTIES. THEREFORE, THE ABOVE EXCLUSIONS MAY NOT APPLY TO YOU.

HOW STATE LAW RELATES TO THE WARRANTY

In the USA, this warranty gives you specific legal rights, and you may also have other rights, which vary from state to state. PolyVision Corporation products are warranted in accordance with the terms of the applicable PolyVision Corporation limited warranty. Product performance is affected by system configuration. Software, the application, customer data, and operator control of products are considered to be compatible with many systems. The specific suitability of a product for a specific purpose or application must be determined by the customer and is not warranted by PolyVision Corporation.