

## CeilingVIEW 70 PTZ HideAway

### Installed PTZ Ceiling Camera with Recessed, Motorized Camera Lift System

**Figure 1:** Vaddio CeilingVIEW 70 PTZ HideAway shown retracted (left) and lowered into operating position (right)



#### INTRODUCTION

Vaddio's CeilingVIEW 70 PTZ HideAway camera system is designed to provide system integrators with an easy to install, recessed, in ceiling, motorized camera lift system (see Figure 1). The system features a Sony® EVI-D70 PTZ Camera mounted into a recessed, metal ceiling camera enclosure with ceiling tile support and is equipped with Vaddio's EZCamera™ Cabling System which allows the integrator to use Cat. 5 cabling to run power, video and camera control. The camera lift has a motorized extension arm, that when retracted, conceals the camera. When the camera is activated the extension arm lowers and reveals the camera.

Contact closure or voltage sensing can be used to activate the lift system remotely or the camera IR remote control can be used to activate the lift with the ON/OFF button. The VISCA control interface is included to allow the camera to work with any other VISCA compatible control device. The PowerRite™ power supply regulates the right amount of power needed for the camera over the Cat. 5 cabling.

#### INTENDED USE

Before operating the Vaddio CeilingVIEW 70 PTZ HideAway, please read the entire manual thoroughly. The camera system was designed, built and tested for use indoors with the provided power supply. The use of a power supply other than the one provided or outdoor operation has not been tested and could damage the camera and/or create a potentially unsafe operating condition.

#### SAVE THESE INSTRUCTIONS

The information contained in this manual will help you install and operate your Vaddio CeilingVIEW 70 PTZ HideAway. If these instructions are misplaced, Vaddio keeps copies of Specifications, Installation and User Guides and most pertinent product drawings for the Vaddio product line on the website. These documents can be downloaded from [www.vaddio.com](http://www.vaddio.com) free of charge.

## IMPORTANT SAFEGAURDS



Read and understand all instructions before using. Do not operate the camera if the camera has been dropped or damaged. In this case, a Vaddio technician must examine the product before operating. To reduce the risk of electric shock, do not immerse in water or other liquids and avoid extremely humid conditions.

**Use only the power supply provided with the CeilingVIEW 70 PTZ HideAway camera system. Use of any unauthorized power supply will void any and all warranties.**

## UNPACKING

Carefully remove the device and all of the parts from the packaging. Unpack and identify the following parts:

- One (1) CeilingVIEW 70 PTZ Camera Module
- One (1) White trim ring with IR sensor attached
- One (1) Vaddio Quick-Connect Box
- One (1) Sony RM-EV100 IR Remote Controller
- One (1) Vaddio PowerRite 18VDC Power Supply
- One (1) AC power cable for Power Supply
- One (1) 12' (4.57m) S-Video cable
- One (1) 12' (4.57m) Composite Video cable
- Two (2) Adjustable ceiling tile support rails
- One (1) RJ-45 to DB9 EZCamera™ serial control converter
- Mounting Hardware
- Installation and User Guide (341-075 Rev. C)

## INSTALLATION



**★ REMOVE the safety tape and then ★ REMOVE the shipping hold-down screw in the back of the camera module as indicated below (see Figure 2. If power (over the Cat. 5 POWER/VIDEO cable) is connected to the camera before the shipping hold-down screw is removed, serious damage to the camera may result.**

**Figure 2:** Top of camera shown with safety tape (left) and location of shipping hold down screw and Power/Video Jack (right).

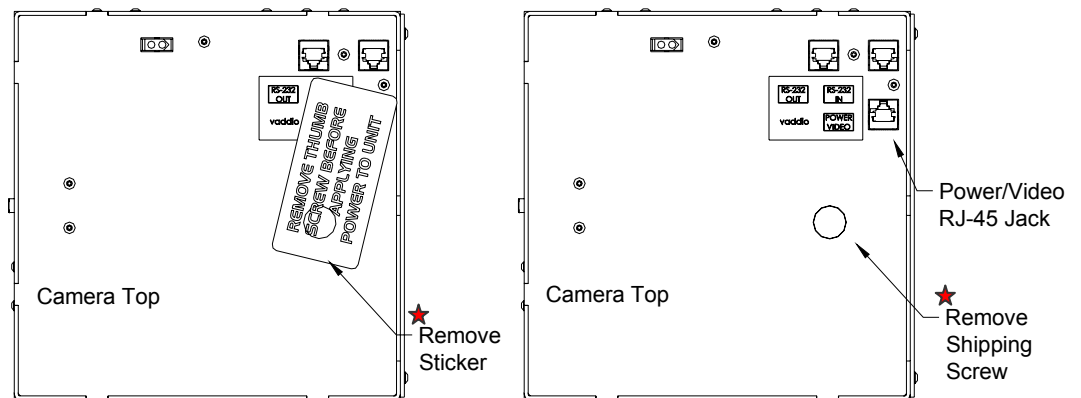

**Getting Started**

The CeilingVIEW 70 PTZ HideAway is an integrated document/object camera specifically designed for installation in a suspended ceiling above a table or work surface. Recommended ceiling heights are between 8 and 12 feet.

**Before Installing**

- Be sure to check above the ceiling tile where you plan to install the camera to make sure the area is clear and that there is enough room for the CeilingVIEW Camera Module and all of its components.
- Keep in mind that other than viewing straight down, the CeilingVIEW PTZ has the capability of panning +/-170 degrees from center.
- The camera may be used with any 2' tile. The camera module enclosure and the tile support rails allow for flexibility and positioning freedom when used with 2'x2' and 2'x4' ceiling tiles.
- For cutting ease, remove the marked ceiling tile and place on a suitable and safe work surface.

**Note:** *If camera is to be controlled as part of a multi camera system, please refer to the section CHANGING CAMERA DEFAULT SETTINGS located on Page 7 of this manual.*

**Step by Step Mounting Instructions**

**To mount the CeilingVIEW 70 PTZ HideAway:**

- 1) Attach a string or plumb bob to the ceiling tile with a thumbtack.
- 2) Position the string directly over ample table space or work surface to allow easy document and object positioning.
- 3) Using a sharp utility knife, score a 6-3/4" diameter circle into the front of the tile centered on the string.
- 4) Carefully cut out the 6-3/4" hole.
- 5) Place the tile support rail on the backside of the tile and center over the hole. Carefully place camera in cutout hole from the back of tile (see Figures 3 and 4) and attach to support rails.

**Figure 3:**  
Side View of CeilingVIEW Camera Module  
For installation reference, the cutout area by the IR detector cable hole is on the side of the camera.

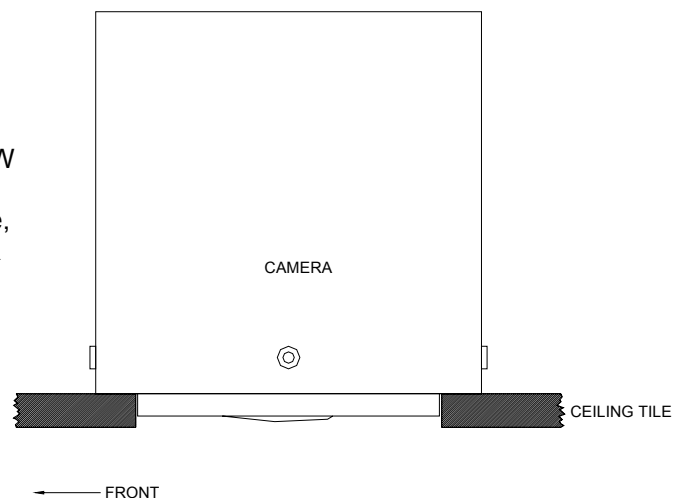

## Cabling the Camera

**Figure 4:**  
Side View and Close-up of Camera module and support rail

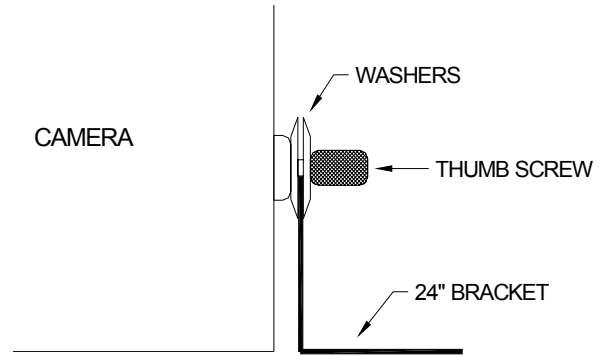

- Using the supplied thumbscrews and washers, attach the support rails to the CeilingVIEW PTZ camera (see Figure 4). Place rail edge between two washers and tighten thumbscrew securely. **Note: The thumbscrew sits on top of the rail, not through the holes on the rail.**
- The Cat.5 cable (plenum rated as code dictates) is run from the ceiling location where the camera is to be mounted, to where the Quick-Connect Box is located (see Figure 5). Both the S-Video and Composite Video outputs are active.

**Figure 5:**  
Quick-Connect Box and connections



- If needed, Cat.5 plenum rated cable(s) may be purchased from Vaddio to connect your camera for video, power control and control daisy-chaining between multiple cameras (see Figure 6).

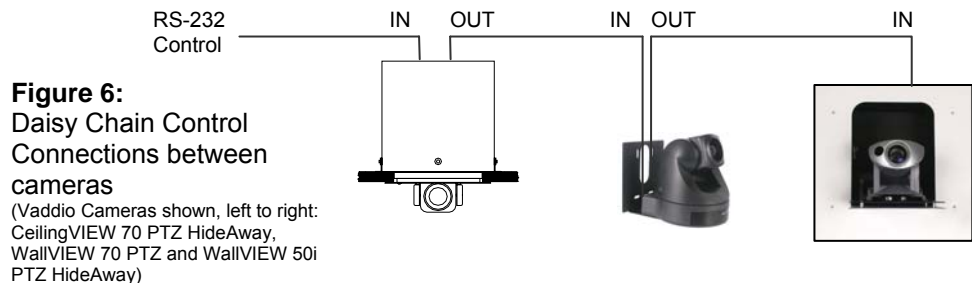

## Connections

- 9) Connections (see Figure 7):
  - a. Attach the installed Cat.5 cable routed from the POWER/VIDEO jack on the back of the camera to the Quick Connect Box.
  - b. If a RS-232 control cable is to be used, it should be attached to the RS-232 IN jack.
  - c. If a second or third camera is to be used, attach a cable to the RS-232 OUT jack and route to the next camera.

**Figure 7:**  
RJ-45 Connections on back  
of Camera Module

- POWER/VIDEO
- RS-232 IN
- RS-232 OUT (for daisy-chain control)

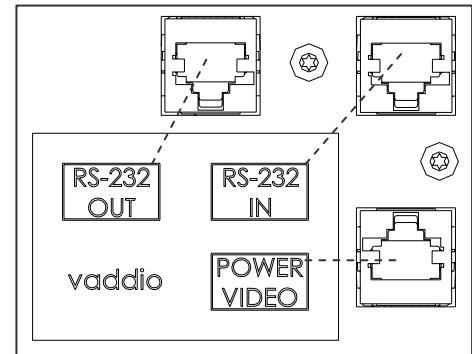

## Finishing Up

- 10) The camera and ceiling tile should be carefully replaced in the suspended ceiling at this time.
- 11) Locate the white trim ring assembly and plug the IR cable into the IR board connector on the trim ring lip (see Figure 8). Take care not to pull any more than about 2 inches of cable from the camera enclosure. The connectors will fit together only one way with a positive click. (**Note: DO NOT hang the trim ring from the camera by the IR cable**) Carefully move trim ring into position on bottom of ceiling tile while feeding IR cable back into camera enclosure and secure with the two supplied white screws.

**Figure 8:**  
Connecting the IR  
sensor on Trim Ring  
to the IR cable

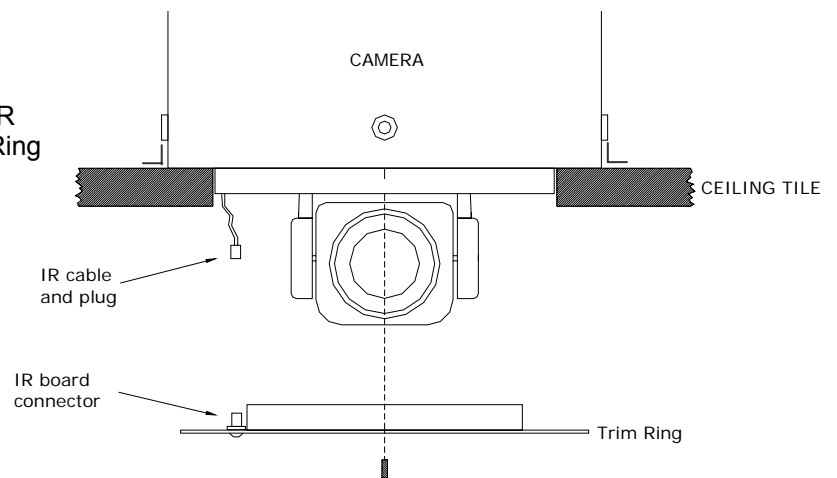

**Initial  
Camera  
Power Up**

12) With the Cat.5 cable routed from the POWER/VIDEO jack on the back of the camera to the Quick Connect Box, connect the supplied Vaddio PowerRite power supply. The camera will lower into position and the S-Video and Composite Video signals will be live and viewable after the camera is fully lowered and in the "Home" position (*Reminder: Use of a power supply other than the provided Vaddio power supply will void warranty and may cause camera and equipment damage*).

**CONTROLLING  
THE CAMERA**

The Camera can be controlled with the Sony RM-EV100 IR Remote Controller or through RS-232 using VISCA control protocols.

**IR Remote**

The Sony RM-EV100 IR Remote Controller controls the following functions when used with a CeilingVIEW 70 PTZ HideAway (see Figure 9). A fresh set of AA batteries (not included) should be installed in the provided Sony remote control. To operate, aim remote at camera and depress desired button.

**Figure 9:**  
RM-EV100 IR Remote Controller

- Power on/off
  - On = Lowers camera
  - Off = Retracts the camera
- Camera Select: 1, 2, 3
- Focus: Auto  
Manual (Near & Far)
- Zoom: Slow – Tele, Wide  
Fast – Tele, Wide
- Back Light: Back Light Compensation
- Pan-Tilt: Left, Right, Up, Down, Reset
- Home: Home/Centered Position
- Position: Preset, Reset
- Presets: 6 (1 through 6)
  
- Cancel: Not Used
- L/R Direction Set: Std, Rev



**Control  
Systems**

If you are using a control system (i.e. Crestron or AMX), plug the Cat.5 cable from the RS-232 IN jack on the camera to your control system using the Cat.5 to DB9 serial adapter supplied by Vaddio. If you are controlling more than one camera, plug the Cat.5 cable from the RS-232 OUT jack on the first camera to the RS-232 IN jack on the second camera. Repeat procedure if third camera is to be used.

**Motor Control  
Only (limited  
use)**

If control of motor only is desired, there is an external connector provided on the top of the camera. This contact is normally open and the motor will be in the retracted state. By providing a contact closure across this connection when power is available and connected via the Cat. 5 POWER/VIDEO cable, the motor will lower,



but will not power up the camera. Release of the closure will retract the camera. The IR Remote Controller or RS-232 commands can power up and lower/retract the camera only. The mating connector can be found at Radio Shack (in the US) under part number 274-226 (see Figure 10).

**Figure 10:**  
Motor Control connection shown

Mating Connector –  
Radio Shack # 274-226

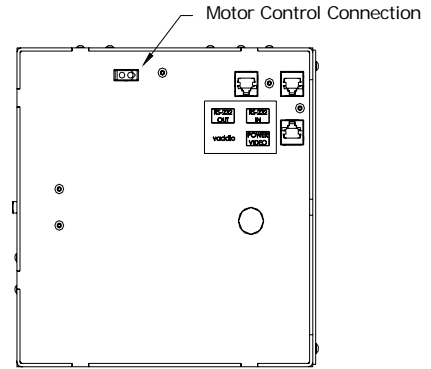

**CHANGING CAMERA  
DEFAULT SETTINGS**

Please refer to Figure 11 for this procedure.

- Camera must first be lowered into place and power unplugged.
- Place camera on suitable work surface.
- Remove the 4 cover plate retainer screws.
- Carefully lift off cover plate while threading the IR cable back through hole.
- Looking between the rear of the EVI-D70 camera body and the interconnect circuit board, locate the 2 switches (it may be necessary to slightly tilt the camera assembly to get the best view of the switches).
- The default setting for the image flip function is ON. Move this switch to the left to disable.
- The default setting for IR select is 1. If this to be camera number 2 in a 2 camera system, set this switch to position 2. If this camera is number 3 in a 3 camera system, set switch to positions 3.
- Carefully thread the IR cable back through the cover plate and secure plate to camera enclosure using the 4 retaining screws.

**Figure 11: Cover Plate Removal and default settings access**

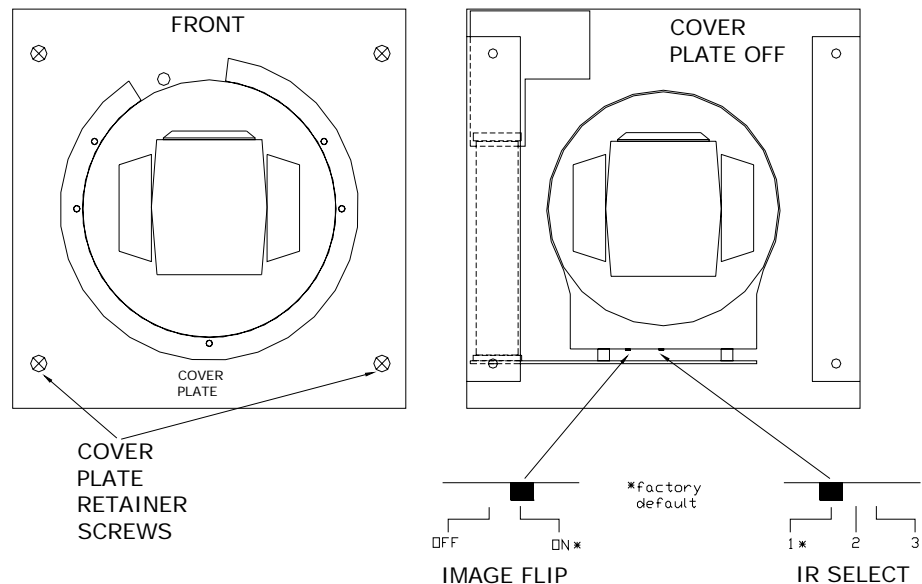



**RS-232  
COMMAND LIST**

Vaddio supplies this control specification for the CeilingVIEW 70 PTZ HideAway camera. This VISCA control set (as used in Sony EVI cameras) is used in conjunction with additional Vaddio control commands (see comment section on Table 1) for added functionality of the camera lift.

**Communication  
Specification**

Communication Speed: 9600 bps (default)  
 Start bit: 1  
 Stop bit: 1  
 Data bits: 8  
 Parity: None

**\*Communication Example:**

For the VISCA Packet "8x 01 04 07 03 FF" (CAM\_Zoom\_Wide), "x" corresponds with the number and order of the camera in the control chain (daisy chain) where x = 1 for the first camera, x = 2 for the second camera, etc...

**Control  
Disclaimer**

The control codes for the CeilingVIEW 70 PTZ HideAway are the same codes used with the EVI-D70 pan/tilt/zoom camera. Vaddio is not translating these codes and does not add any translation or memory capability to enable use of the EVI-D70 camera as a main or auxiliary camera with videoconferencing system codecs or the associated IR remote controllers.

For best control results, use the provided RM-EV100 IR Remote Controller or the VISCA Commands (detailed in Table 1 below) with an external control system.

**Command List**

**Table 1: VISCA Command List**

RS-232 Command Set	Command	Command Packet*	Comments
AddressSet	Broadcast	88 30 01 FF	Address setting
IF_Clear	Broadcast	88 01 00 01 FF	I/F Clear
CommandCancel		8x 2p FF	p: Socket No.(=1or2)
CAM_Power	On	8x 01 04 00 02 FF	Power ON – <i>Lowers Camera Lift Mechanism</i> and Turns camera ON
	Off(Standby)	8x 01 04 00 03 FF	Power OFF – <i>Retracts Camera Lift Mechanism</i> and Turns camera OFF
CAM_Zoom	Stop	8x 01 04 07 00 FF	
	Tele(Standard)	8x 01 04 07 02 FF	No
	Wide(Standard)	8x 01 04 07 03 FF	
	Tele(Variable)	8x 01 04 07 2p FF	p=0 (Low) ~7 (Fast)
	Wide(Variable)	8x 01 04 07 3p FF	
	Direct	8x 01 04 47 0p 0q 0r 0s FF	pqrs: Zoom Position
CAM_Dzoom	D-Zoom On	8x 01 04 06 02 FF	Digital Zoom ON/OFF
	D-Zoom Off	8x 01 04 06 03 FF	
CAM_Focus	Stop	8x 01 04 08 00 FF	
	Far(Standard)	8x 01 04 08 02 FF	
	Near(Standard)	8x 01 04 08 03 FF	
	Far(Variable)	8x 01 04 08 2p FF	p=0 (Low) ~7 (High)
	Near(Variable)	8x 01 04 08 3p FF	
	Direct	8x 01 04 48 0p 0q 0r 0s FF	pqrs: Focus Position
	Auto Focus	8x 01 04 38 02 FF	AF ON/OFF
	Manual Focus	8x 01 04 38 03 FF	
	Auto/Manual	8x 01 04 38 10 FF	



**Command List  
(Continued)**

	One Push Trigger	8x 01 04 18 01 FF	One Push AF Trigger
	Infinity	8x 01 04 18 02 FF	Forced Infinity
	Near Limit	8x 01 04 28 0p 0q 0r 0s FF	pqrs: Focus Near Limit Position
AF Sensitivity	Normal	8x 01 04 58 02 FF	AF Sensitivity Norm/Low
	Low	8x 01 04 58 03 FF	
CAM_ZoomFocus	Direct	8x 01 04 47 0p 0q 0r 0s 0t 0u 0v 0w FF	pqrs: Zoom Position tuvw: Focus Position
CAM_WB	Auto	8x 01 04 35 00 FF	Normal Auto
	Indoor	8x 01 04 35 01 FF	Indoor Mode
	Outdoor	8x 01 04 35 02 FF	Outdoor Mode
	One Push WB	8x 01 04 35 03 FF	One Push WB Mode
	ATW	8x 01 04 35 04 FF	Auto Tracing White Mode
	Manual	8x 01 04 35 05 FF	Manual Control Mode
	One Push Trigger	8x 01 04 10 05 FF	One Push WB trigger
CAM_RGain	Reset	8x 01 04 03 00 FF	R Gain Manual setting
	Up	8x 01 04 03 02 FF	
	Down	8x 01 04 03 03 FF	
	Direct	8x 01 04 43 0p 0q 0r 0s FF	pqrs: R Gain
CAM_BGain	Reset	8x 01 04 04 00 FF	B Gain Manual setting
	Up	8x 01 04 04 02 FF	
	Down	8x 01 04 04 03 FF	
	Direct	8x 01 04 44 0p 0q 0r 0s FF	pqrs: B Gain
CAM_AE	Full Auto	8x 01 04 39 00 FF	Automatic exposure mode
	Manual	8x 01 04 39 03 FF	Manual control mode
	Shutter Priority	8x 01 04 39 0A FF	Shutter priority auto exposure mode
	Iris Priority	8x 01 04 39 0B FF	Iris priority auto exposure mode
	Bright	8x 01 04 39 0D FF	Bright mode (Manual)
CAM_SlowShutter	Auto	8x 01 04 5A 02 FF	AutoSlowShutter ON/OFF
	Manual	8x 01 04 5A 03 FF	
CAM_Shutter	Reset	8x 01 04 0A 00 FF	Shutter setting (1/4sec~1/10000sec)
	Up	8x 01 04 0A 02 FF	
	Down	8x 01 04 0A 03 FF	
	Direct	8x 01 04 4A 00 00 0p 0q FF	pq: Shutter Position
CAM_Iris	Reset	8x 01 04 0B 00 FF	Iris setting
	Up	8x 01 04 0B 02 FF	
	Down	8x 01 04 0B 03 FF	
	Direct	8x 01 04 4B 00 00 0p 0q FF	pq: Iris Position
CAM_Gain	Reset	8x 01 04 0C 00 FF	Gain setting
	Up	8x 01 04 0C 02 FF	

**Command List  
(Continued)**

	Down	8x 01 04 0C 03 FF	
	Direct	8x 01 04 4C 00 00 0p 0q FF	pqrs: Gain Position
CAM_Bright	Reset	8x 01 04 0D 00 FF	Bright setting
	Up	8x 01 04 0D 02 FF	
	Down	8x 01 04 0D 03 FF	
	Direct	8x 01 04 4D 00 00 0p 0q FF	pqrs: Bright Position
CAM_ExpComp	On	8x 01 04 3E 02 FF	Exposure Compensation ON/OFF
	Off	8x 01 04 3E 03 FF	
	Reset	8x 01 04 0E 00 FF	Exposure Compensation amount setting
	Up	8x 01 04 0E 02 FF	
	Down	8x 01 04 0E 03 FF	
	Direct	8x 01 04 4E 00 00 0p 0q FF	pqrs: ExpComp Position
CAM_BackLight	On	8x 01 04 33 02 FF	Back Light Compensation
	Off	8x 01 04 33 03 FF	
CAM_SpotAE	On	8x 01 04 59 02 FF	Setting for AE
	Off	8x 01 04 59 03 FF	
	Position	8x 01 04 29 0p 0q 0r 0s FF	pq: X(0 to F) , rs: Y(0 to F)
CAM_Aperture CAM_Aperture	Reset	8x 01 04 02 00 FF	Aperture Control
	Up	8x 01 04 02 02 FF	
	Down	8x 01 04 02 03 FF	
	Direct	8x 01 04 42 0p 0q 0r 0s FF	pqrs: Aperture Gain
CAM_LR_Reverse	On	8x 01 04 61 02 FF	Mirror Image ON/OFF
	Off	8x 01 04 61 03 FF	
CAM_Freeze	On	8x 01 04 62 02 FF	Freeze Picture ON/OFF
	Off	8x 01 04 62 03 FF	
CAM_PictureEffect	Off	8x 01 04 63 00 FF	Picture Effect setting
	Neg.Art	8x 01 04 63 02 FF	
	B&W	8x 01 04 63 04 FF	
CAM_ICR	On	8x 01 04 01 02 FF	ICR Mode ON/OFF
	Off	8x 01 04 01 03 FF	
CAM_AutoICR	On	8x 01 04 51 02 FF	Auto ICR ON/OFF
	Off	8x 01 04 51 03 FF	
CAM_Memory	Reset	8x 01 04 3F 00 pp FF	p: Memory number (=0 to 5)
	Set	8x 01 04 3F 01 pp FF	
	Recall	8x 01 04 3F 02 pp FF	
CAM_Mute	On	8x 01 04 75 02 FF	Mute ON/OFF
	Off	8x 01 04 75 03 FF	
	On/Off	8x 01 04 75 10 FF	
CAM_Display	On	8x 01 04 15 02 FF	Display On/Off



**Command List  
(Continued)**

		(8x 01 06 06 02 FF)	
	Off	8x 01 04 15 03 FF	
		(8x 01 06 06 03 FF)	
	On/Off	8x 01 04 15 10 FF	
		(8x 01 06 06 10 FF)	
CAM_Title	Title Set1	8x 01 04 73 00 mm nn pp qq 00 00 00 00 00 00 FF	mm: V-Position, nn H-Position pp: Color, qq:Blink
	Title Set2	8x 01 04 73 01 mm nn pp qq rr ss tt uu vv ww FF	mnpqrstuvwxyz: Set of characters ( 1 to 10)
	Title Set3	8x 01 04 73 02 mm nn pp qq rr ss tt uu vv ww FF	mnpqrstuvwxyz: Set of characters ( 11 to 20)
	Title Clear	8x 01 04 74 00 FF	Title Set clear
	On	8x 01 04 74 02 FF	Title display On/Off
	Off	8x 01 04 74 03 FF	
CAM_IDWrite		8x 01 04 22 0p 0q 0r 0s FF	pqrs: Camera ID (=0000~FFFF)
CAM_Alarm	On	8x 01 04 6B 02 FF	Alarm On/Off
	Off	8x 01 04 6B 03 FF	
	SetMode	8x 01 04 6C pp FF	pp: Set the mode(00 -- 0C)
			00 Detect the Focus position (Not update the original data)
			01 Detect the Focus position (Update the original data)
			02 Detect the AE level (Not update the original data)
	SetDayNightLevel	8x 01 04 6D 0p 0p 0p 0q 0q 0q FF	03 Detect the AE level (Update the original data)
			Set the AE level of judgment of Day (ppp) and Night(qqq)
Alarm (Reply)	y0 07 04 6B 01 FF	Detect level "Low" to "High"	
		y0 07 04 6B 00 FF	Detect level "High" to "Low"
Pan/Tilt Drive	Up	8x 01 06 01 VV WW 03 01 FF	VV: Pan Speed 01 to 18 WW: Tilt Speed 01 to 17 YYYY: Pan Position F725 to 08DB (center 0000) ZZZZ: Tilt Position FE70 to 04B0 (Image Flip: off) (center 0000) Tilt Position FB50 to 0190 (Image Flip: ON) (center 0000)
	Down	8x 01 06 01 VV WW 03 02 FF	
	Left	8x 01 06 01 VV WW 01 03 FF	
	Right	8x 01 06 01 VV WW 02 03 FF	
	Up-Left	8x 01 06 01 VV WW 01 01 FF	
	Up-Right	8x 01 06 01 VV WW 02 01 FF	
	Down-Left	8x 01 06 01 VV WW 01 02 FF	
	Down-Right	8x 01 06 01 VV WW 02 02 FF	
	Stop	8x 01 06 01 VV WW 03 03 FF	
	Absolute Position	8x 01 06 02 vv WW 0Y 0Y 0Y 0Y 0Z 0Z 0Z 0Z FF	
	Relative Position	8x 01 06 03 vv WW 0Y 0Y 0Y 0Y 0Z 0Z 0Z 0Z FF	
	Home	8x 01 06 04 FF	
	Reset	8x 01 06 05 ff	



**TROUBLESHOOTING**

Problem	Questions for Troubleshooting
<b>No image</b>	Is the Vaddio supplied power supply connected to a working AC wall outlet?
	Is Vaddio power supply securely connected to wall plate or Quick Connect box?
	Is the Category 5 signal cable securely connected to the wall plate or Quick Connect box?
	Is the Category 5 signal cable connected to correct port on the camera?
<b>Camera will not respond to IR Remote</b>	Have fresh AA batteries been installed in the IR Remote control?
	Is remote being aimed directly at camera during use?
	Is the camera power on?
<b>Camera will not respond to control system RS-232 control commands</b>	Verify correct serial connection to control device.
	Is Category 5 RS-232 cable connected to the RS-232 IN jack on the camera?
	Verify correct VISCA commands as per the serial command list.
	If camera is used in a multi camera system, is the correct camera being addressed?
	Is the camera power on?

**SPECIFICATIONS**

Specification	CeilingVIEW 70 PTZ HideAway	
Part Number	<b>999-2404-000</b>	<b>999-2404-001</b>
Signal system	NTSC	PAL
Image sensor	1/4-type EXview HAD CCD	
Effective Pixels	768 x 494 (H x V)	752 x 582 (H x V)
Horizontal Resolution	470 TV lines	460 TV lines
Lens	18X Optical Zoom, f=4.1 mm (wide) to 73.8 mm (tele), F1.4 to F3.0	
Total Zoom	18X Optical x 12X Digital = 216X Total Zoom	
Horizontal angle of view	2.7° (tele end) to 48° (wide end)	
Minimum illumination	1 Lux (F1.4)	
Auto exposure	Auto/Manual/Priority AE, Exposure compensation, Back-light compensation	
Shutter speed	1 to 1/10,000 s	
Gain	Auto/Manual (-3 to +28 dB, 2 dB steps)	
White balance	Auto/ATW/Indoor/Outdoor/One push/Manual	
S/N ratio	More than 50 dB	
Pan/tilt	Pan: ±170° (Max. speed: 100°/s), Tilt: -30° to +90° (Max. speed: 90°/s)	
Position preset	6 positions	
Picture effect	Neg. Art, Black & White	
Video outputs	Composite Video and S-Video (concurrent)	
Power requirement	10.8 VDC to 13.2 VDC	
Power consumption	Idle: 12w Engaged: 23W	
Power Supply	18 VDC, 2.78A (PowerRite Power Supply Spec), 100V– 240V Switcher	
Operating Temperature	32 to 104° F (0 to 40° C)	
Storage Temperature	-4 to +140° F (-20 to +60° C)	
Dimensions	8.84" (22.45cm) H x 8.75" (22.23cm) W x 8.65" (21.97cm) D	
Weight	8.4 lbs / 3.81 kg	

**COMPLIANCE**



**FCC Part 15 Compliance and EC Declaration of Conformity**

Sony Corporation holds the FCC and CE certifications for the EVI-D70 and EVI-D70P cameras used internal to the CeilingVIEW 70 PTZ HideAway mechanical enclosure. Please contact Sony Corporation for this documentation.



## WARRANTY INFORMATION

**Hardware\* Warranty** - One year limited warranty on all parts. Vaddio warrants this product against defects in materials and workmanship for a period of one year from the day of purchase if Vaddio receives notice of such defects during the warranty. They will, at its option, repair or replace products that prove to be defective.

**Exclusions** - The above warranty shall not apply to defects resulting from: improper or inadequate maintenance by the customer, customer applied software or interfacing, unauthorized modifications or misuse, operation outside the normal environmental specifications for the product, use of the incorrect power supply, or improper site operation and maintenance.

**Vaddio Customer service** – Vaddio will test, repair, or replace the product or products without charge if the unit is under warranty. If the product is out of warranty, Vaddio will test then repair the product or products. The cost of parts and labor charge will be estimated by a technician and confirmed by the customer prior to repair. All components must be returned for testing as a complete unit. Vaddio will not accept responsibility for shipment after it has left the premises.

**Vaddio Technical support** - Vaddio technicians will determine and discuss with the customer the criteria for repair costs and/or replacement. Vaddio Technical Support can be contacted through one of the following resources: e-mail support at [vaddio\\_support@photo-control.com](mailto:vaddio_support@photo-control.com) or online at [www.vaddio.com](http://www.vaddio.com).

**Return Material Authorization (RMA) number** - Before returning a product for repair or replacement request an RMA from Vaddio's technical support. Provide a technician with a return phone number, e-mail address, shipping address, and product serial numbers. Describe the reason for repairs or returns as well as the date of purchase. Include your assigned RMA number in all correspondence with Vaddio. Write your assigned RMA number on the outside of the box when returning the product.

**Voided warranty** – The warranty does not apply if the original serial number has been removed or if the product has been disassembled or damaged through misuse, accident, modifications, or unauthorized repair.

**Shipping and handling** - Vaddio will not pay for inbound shipping transportation or insurance charges or accept any responsibility for laws and ordinances from inbound transit. Vaddio will pay for outbound shipping, transportation, and insurance charges all items under warranty but will not assume responsibility for loss and/or damage by the outbound freight carrier.

- If the return shipment appears damaged, retain the original boxes and packing material for inspection by the carrier.
  - Contact your carrier immediately.

**Products not under warranty** - Payment arrangements are required before outbound shipment for all out of warranty products.

\*Vaddio manufactures its hardware products from parts and components that are new or equivalent to new in accordance with industry standard practices.

Do not attempt to take the camera module apart (other than for the reasons stated in the manual). There are no user-serviceable components inside.

- Do not spill liquids onto the camera
- Keep this device away from food and liquid
- Avoid touching the lens
- For smears or smudges, clear any dust with a blower and wipe stains with a glass cleaner and clean, soft cloth.
- To clean exterior of camera, wipe with a clean soft cloth. Do not use any abrasive chemicals.

## CARE AND CLEANING

Do not operate the CeilingVIEW 70 PTZ HideAway under the following conditions for any circumstance:

- Temperatures above 40°C (104°F)
- Temperatures below 0°C (32°F)
- High humidity, condensing or wet environments
- Dusty environments
- In inclement weather
- Under severe vibration

## OPERATING CONDITIONS

