



SERIES 490W | WIRELESS HYDRONIC DIFFERENTIAL PRESSURE MANOMETER



FEATURES/BENEFITS

- Rugged weatherproof handheld housing withstands 1.5 meter drop test
- Wireless measurement of differential pressure, single pressure and air flow
- Share logged data directly from handheld over Wi-Fi, GSM or CDMA networks
- Ergonomic design is much lighter and easier to work with, providing greater maneuverability and quick install setup

APPLICATIONS

- Refrigerant pressure testing
- Hydronic valve balancing
- Measure pressure drop across pumps
- Measure pressure drop across chiller and coils for freeze protection

DESCRIPTION

Series 490W Wireless Hydronic Differential Pressure Manometer is the most accurate and easy to operate manometer on the market. By using wireless transducers and a versatile handheld, a single operator can monitor and balance a hydronic system in less time than traditional hydronic balancers. The Series 490W utilizes mobile technology to communicate via a Bluetooth connection with the transducers to monitor differential pressure and flow on up to three different valves. Being wireless means there are no hoses to carry, snag on equipment or needing to be drained. The 490W includes the Dwyer Hydronic Application Software that contains valve charts for numerous manufacturers, which converts differential pressure to flow directly on the screen.

SPECIFICATIONS

Wireless Distance	Up to 65' (19.8 m).
Service	Compatible gases & liquids.
Wetted Materials	316 SS, PTFE, brass.
Accuracy	2% of reading, ± 1 psi.
Compensated Temperature Range	14 to 140°F (-10 to 60°C).
Pressure Hysteresis	$\pm 0.25\%$ FS.
Pressure Limits	0-50 psi and 0-200 psi (see chart for more ranges).
Process Temperature Limits	-4 to 185°F (-20 to 85°C).
Display	5" Gorilla® glass 3, touch screen, 1280x720.
Resolution	0.01 psi.
Process Connections	Two 1/4" male NPT.
Power Requirements	CR2050 lithium battery, user replaceable.
Weight	2 lb (907 g).
Agency Approvals	CE, FCC.

DIMENSIONS

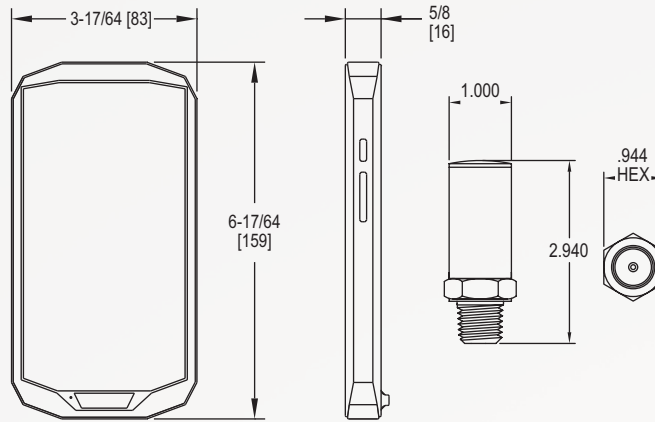

HOW TO ORDER

Use the **bold** characters from the chart below to construct a product code.

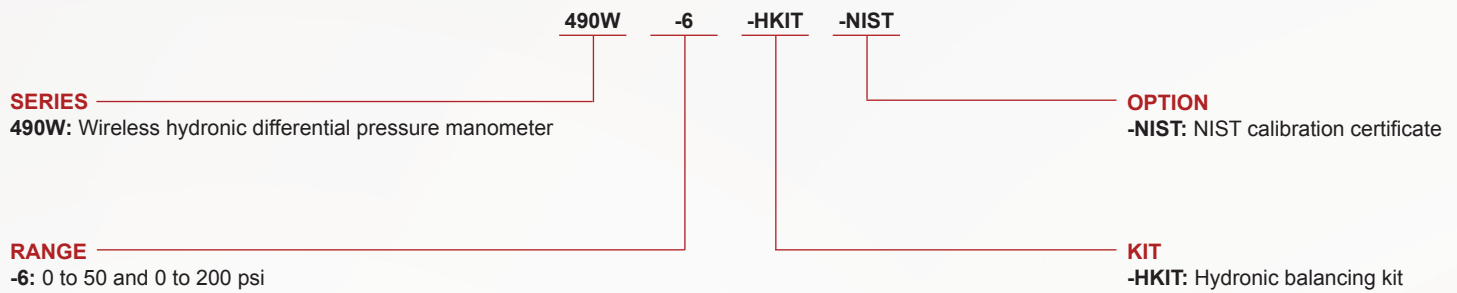

ACCESSORIES

Model	Description
A-490W-1	0 to 15 psid replacement sensors [2 paired sensors]
A-490W-2	0 to 30 psid replacement sensors [2 paired sensors]
A-490W-3	0 to 50 psid replacement sensors [2 paired sensors]
A-490W-4	0 to 100 psid replacement sensors [2 paired sensors]
A-490W-5	0 to 500 psid replacement sensors [2 paired sensors]
A-490W-6	0 to 200 psid replacement sensors [2 paired sensors]
A-HKIT-500	Piercing gage adapter, 1/8" dia x 1-1/2" length (2 per kit)
A-HKIT-500XL	Piercing gage adapter, 1/8" dia x 3" length (2 per kit)
A-HKIT-510	Piercing gage adapter, 1/16" dia x 1-1/2" length (2 per kit)

ORDER ONLINE TODAY!

dwyer-inst.com/Product/Series490W



DWYER INSTRUMENTS, INC.

©Copyright 2019 Dwyer Instruments, Inc.
Printed in U.S.A. 7/19

DS-490W Rev. 1

Important Notice: Dwyer Instruments, Inc. reserves the right to make changes to or discontinue any product or service identified in this publication without notice. Dwyer advises its customers to obtain the latest version of the relevant information to verify, before placing any orders, that the information being relied upon is current.