

ELMO

PTC-400C

Pan / Tilt / Zoom Camera

Touchboards

205 Westwood Ave, Long Branch, NJ 07740
Phone: 866-94 BOARDS (26273) / (732)-222-1511
Fax: (732)-222-7088 | E-mail: sales@touchboards.com



ELMO offers a new pan/tilt/zoom camera that monitors practically every direction with wide pan/tilt capability with Image flip function, and various user-friendly features.

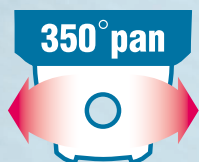

Max. 192x zoom
(12x Optical, 16x Digital)

Max. 100° / sec.
pan / tilt speed

**2 Alarm Inputs /
16 Presets**

Max. 80x
Electronic sensitizing

**Day / Night
function**

**IR
remote control**

**RS-485
connection**

PTC-400C Pan / Tilt / Zoom Camera

SPECIFICATIONS

TV System	NTSC
Image pick-up device	1/4 inch IT color CCD
Total pixels / Effective pixels	410,000 pixels/380,000 pixels
Sync.system	Internal
Resolution(Horizontal/Vertical)	470TV lines (H) x 360TV lines (V)
S/N ratio	More than 49dB
Minimum illumination	1 lx (30IRE)
Lens	12x powered zoom, f=3.8~45.6mm, F1.6~2.7
Zoom	12x powered optical zoom
Field of view (horizontal)	52.8°~4.5°
CAMERA CONTROLS	
Backlight compensation	Provided
Iris selection	Auto (OPEN / CLOSE / NORMAL)
White balance	AUTO/MANU/PUSH/Fixed
Focus	Full-auto/Manual
Picture adjustment	hue, AGC gain, detail compensation, high speed shutter etc.
Digital zoom	16x (MAX)
Electronic sensitizing	80x (MAX)
Area masking	Provided
Image flip	Provided (for Tilt 180° control)
Day/Night function	Provided (IR cut filter removal)
PAN/TILT CONTROLS	
Pan (H)	±175° (350° in total, max.speed 100°/sec.)
Tilt (V)	-195° to 15° (210° in total, max.speed 100°/sec.)
Auto return to home position	Provided
Speed control	Auto/Manual (8 speeds)
Preset	16 positions
Pan/Tilt range setting	"ON" when Dome cover is mounted
OTHER CONTROLS	
Control of multiple cameras with remote controller	Up to 9 cameras
Power ON/OFF with remote controller	Provided
Power save mode	Provided
Preset title indication	Provided (Up to 10 characters)
RS-485 daisy chain connection	Up to 223 cameras
Receivable angle from IR remote controller	Front : +30°, Light & Right : ±60°
Power requirement	DC12V 12W
Operating temperature	-10°~50°
Dimensions	φ139.2 x 120.5 (projections and metal fitting not included)
Main unit weight	Approx. 790g (without metal fitting)
Supplied accessories	IR remote controller, Instruction manual, Warranty card, Connection cable

Design and specifications are subject to change without prior notice.
Dimensions and weight are approximate.

PROFILE

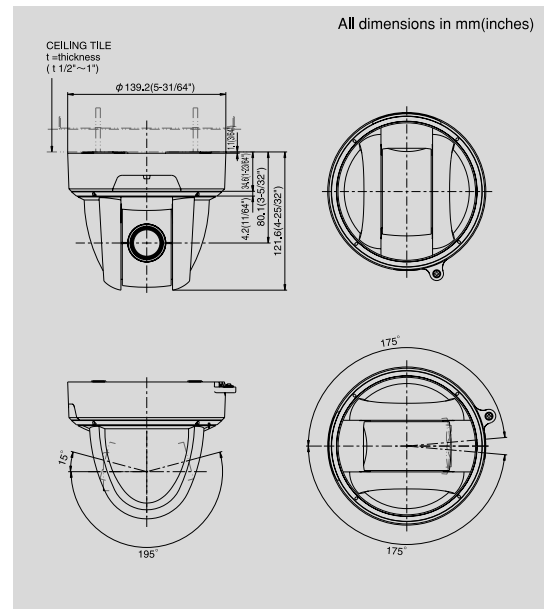

OPTIONAL ACCESSORY

Optional Dome Covers are available for PTC-400C



Clear type : PTC40CL

Smoke type : PTC40SM



ELMO is a trademark of ELMO COMPANY, LIMITED.

ELMO CO., LTD.

6-14, Meizen-cho, Mizuho-ku,
Nagoya, 467-8567, Japan
E-Mail: foreign-div@elmo.co.jp
Tel. 81-52-821-3141
Fax. 81-52-811-5243

Distributed by

Additional technical information is available from any of the following subsidiary companies;

ELMO Mfg. Corp.

1478 Old Country Road,
Plainview, NY 11803-5034, U.S.A.
Tel. 516-501-1400 Fax. 516-501-0429
E-mail: elmo@elmousa.com
Web: <http://www.elmousa.com>

ELMO (Europe) G.m.b.H.

Neanderstr 18,
40233 Düsseldorf, Germany
Tel. 0211-3864-70 Fax. 0211-376630
E-mail: info@elmoeurope.com
Web: <http://www.elmoeurope.com>

ELMO Canada Mfg. Corp.

44 West Drive, Brampton,
Ontario, L6T 3T6, Canada
Tel. 905-453-7880 Fax. 905-453-2391
E-mail: info@elmocanada.com
Web: <http://www.elmocanada.com>



This brochure is printed on recycled paper with soy ink.

E04009 Printed in Japan(A)11/2004