

## Solution 1

ARTICULATING ARM and  
KEYBOARD PLATFORM

Model SOLUTION 1  
Model SOLUTION 1CC

SOLUTION 1 Rev A 4/17

SOLUTION 1

SOLUTION 1CC



# INSTALLATION AND USE

**PLEASE REVIEW** these instructions before beginning the installation. Check that all parts needed were provided with your order. Contact your supplier if any parts are missing. Do not discard the packaging until satisfied that the product operates to your satisfaction.

Solution 1 combines the AA260 articulating arm with the PL003-25 keyboard platform. In this instruction booklet, installation of the two products will be explained in sequence, beginning with the AA260.

**AA260 PARTS PROVIDED**

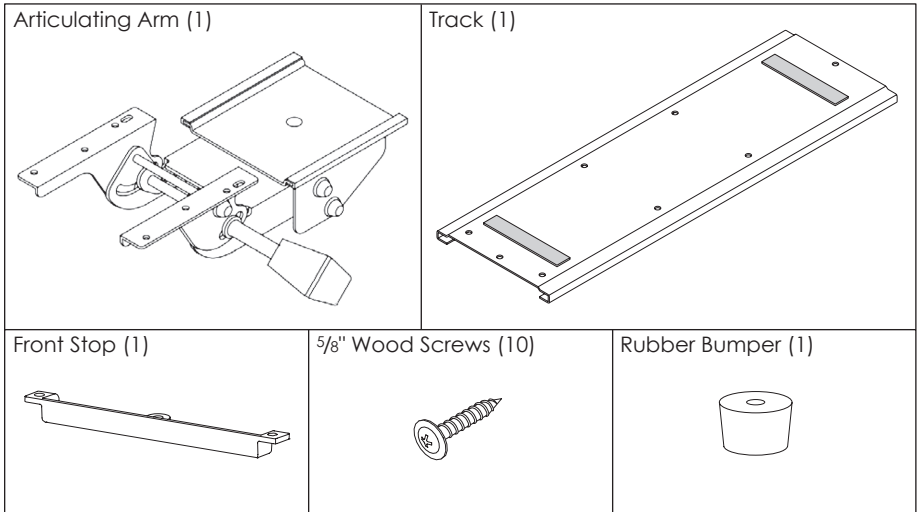

**CAUTION:** This install requires power tool or Cordless Drill. This is **not** a hand tool install.

**ADDITIONAL TOOLS REQUIRED**

- Drill with 1/8" bit
- #2 Phillips Screw Driver Bit

**STEP 1: Adhere Track**

- Peel the backing from the adhesive strips on top of the track.
- Adhere the track to the underside of the work surface.
  - Position the front edge of the track 1/4" from the front edge of the work surface. The front of the track is the end with three holes.
- Press the track firmly in place.

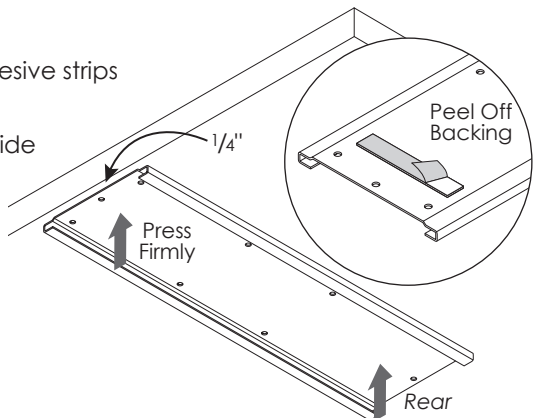

**STEP 2: Attach Track**

- Drill  $\frac{1}{8}$ " pilot holes through all eight holes in the track.  
— Drill the holes  $\frac{5}{8}$ " deep.

**CAUTION:** Be careful not to drill through the top of the work surface.

- Attach the track with screws through the six side holes first.
- Attach the rubber bumper at the rear center hole.
- Do not screw through the front center hole at this time.

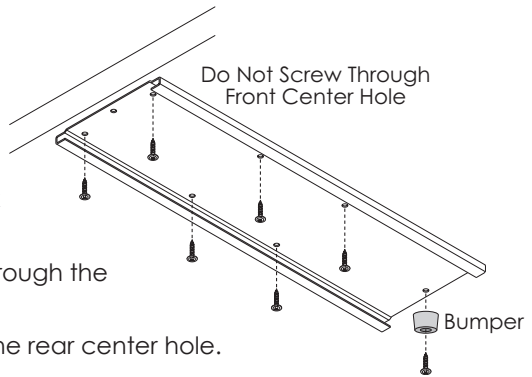
**STEP 3: Install Articulating Arm**

- Slide the articulating arm onto the track. Position it back far enough so that you have access to the front center hole on the track.

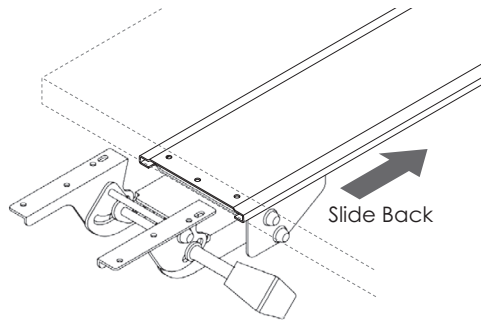
**STEP 4: Attach Front Stop**



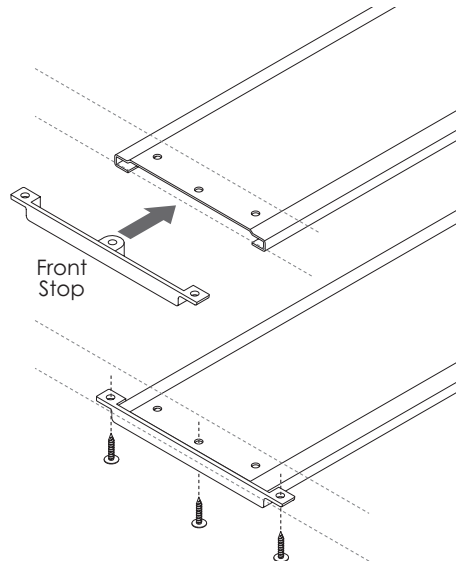

- Position the front stop onto the front of the track and secure it with a screw through the center hole.
- Drill pilot holes for the two side screws and attach the ends of the front stop with two more screws.

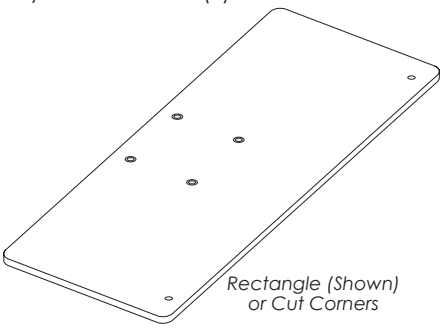
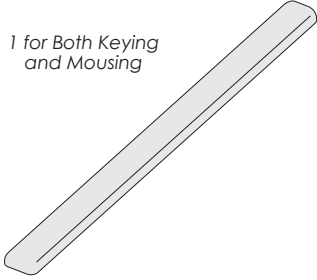

Proceed to STEP 5 on page 4.

The keyboard platform for Solution 1 is PL003-25 (rectangle) or PL003-25CC (cut corners). Although the appearance varies, installation procedures are identical.

**PL003-25 PARTS PROVIDED**

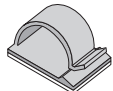
<p>Keyboard Platform (1)</p>  <p>Rectangle (Shown) or Cut Corners</p>	<p>Palm Rest (1)</p> <p>1 for Both Keying and Mousing</p> 		
<p>Flathead Screw (4)</p>  <p>#8-32x1/2</p>	<p>Flange Nut (4)</p>  <p>#8x32</p>	<p>Panhead Screw (2)</p>  <p>#8-32x5/8 (R-Series: #8-32x3/4)</p>	<p>Cord Clips (2)</p> 

**CAUTION:** Hand-tighten screws only. Do **not** use power tools.

**ADDITIONAL TOOLS REQUIRED**

- Phillips screwdriver

**STEP 5: Attach Palm Rest(s)**

- Attach the palm rest(s) to the keyboard platform. Use the #8-32x5/8 panhead screws (#8-32x3/4 with the R-Series) and a Phillips screwdriver. Two screw holes are located in the keyboard platform to accommodate a variety of installation possibilities.
  - With one palm rest, attach it with two screws through the two end holes.
  - With two separate palm rests, attach each with two screws, as shown.
  - The mouse and keyboard palm rests may be attached on either the left or right sides of the keyboard platform.

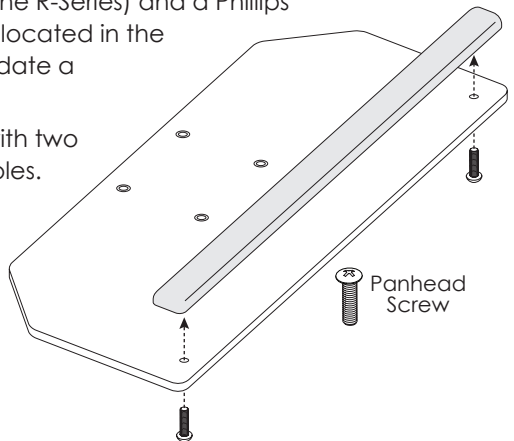

### **STEP 6: Attach Keyboard Platform**

- Attach the keyboard platform to the keyboard arm and track assembly using the four flathead screws and flange nuts.

— Be sure the flange on the nuts is facing upward.

**IMPORTANT:** The flange nuts must be fully tightened to ensure the nuts are locked. Use a Phillips screwdriver.

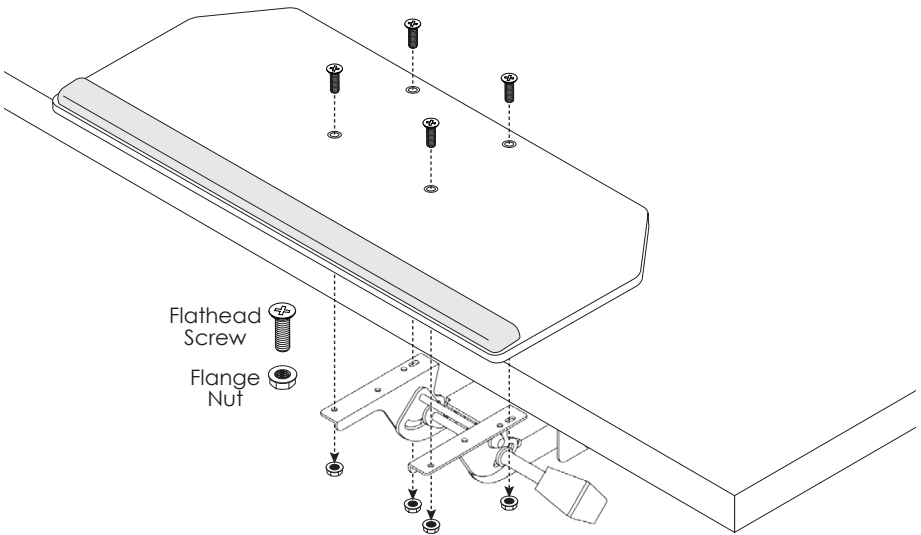

### **STEP 7: Manage Cables**

- Adhere cord clips to the underside of the keyboard platform as needed to organize the keyboard and mouse cables.

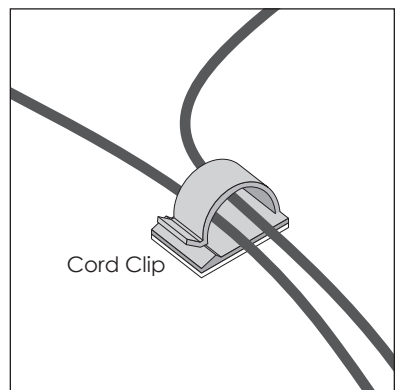

## OPERATION

### To Raise or Lower:

- Use the handle to move the platform up or down.

### To Set Tilt Angle:

- Loosen the handle and adjust the tilt angle to the desired position.
- Tighten the handle to lock the angle in position.



800.833.3746 | [esiergo.com](http://esiergo.com)