

## Q CRANK

CRANK TABLE BASE

Model Q Crank-24S-\_\_\_  
Model Q Crank-24L-\_\_\_  
Model Q Crank-30S-\_\_\_  
Model Q Crank-30L-\_\_\_

Q CRANK Rev A 1/17

\_\_\_ = SLV, BLK or WHT

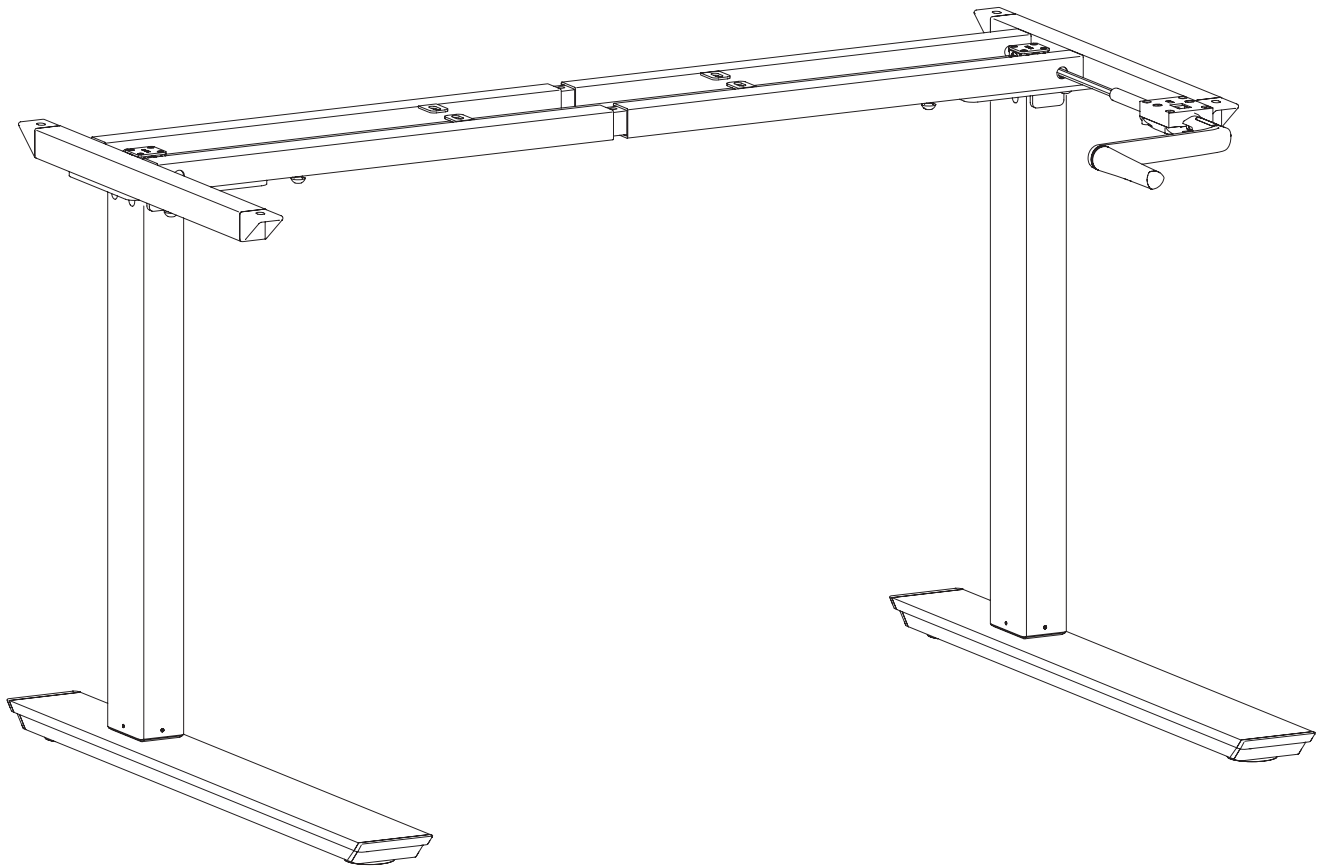

# ASSEMBLY AND OPERATION

**PLEASE REVIEW** these instructions before beginning the assembly procedures. Check that all the parts shown below were provided with your order. Contact your supplier if any materials are missing. Do not discard the packaging until satisfied that the product operates to your satisfaction.

**PARTS PROVIDED**

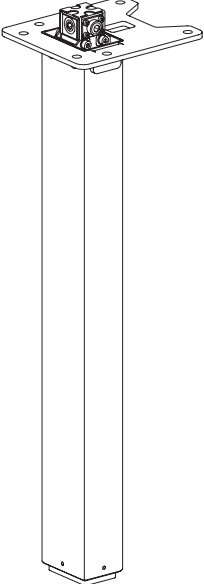
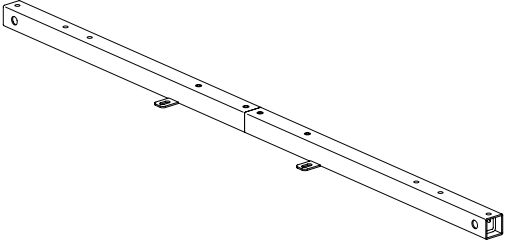
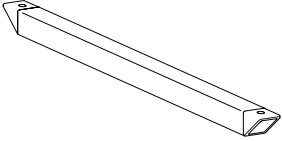
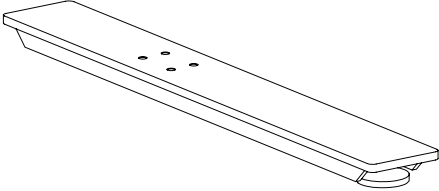
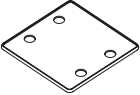
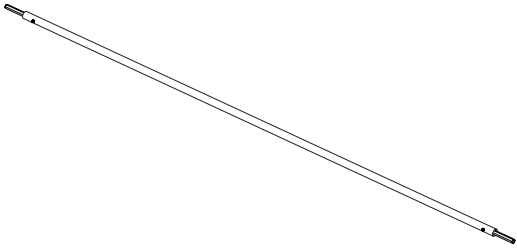
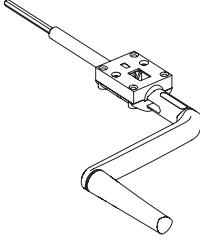
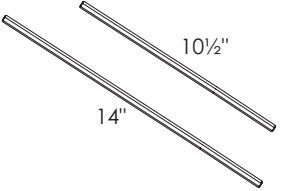
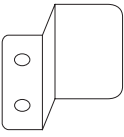
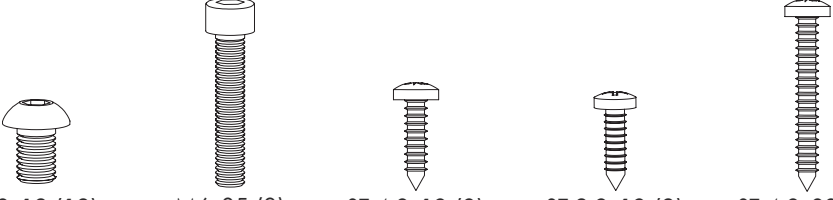
<p>Legs (2)</p> 	<p>Cross Channels (2)</p> 	<p>Top Supports (2)</p> 
	<p>Feet (2)</p> 	<p>Foot Plates (2)</p> 
<p>Gear Connector (1)</p> 	<p>Crank Handle (1)</p> 	<p>Additional Crank Handle Shafts (1 each)</p> 
<p>Crank Handle Bracket (1)</p> 	<p>Fasteners</p>  <p>M8x12 (12)      M6x35 (8)      ST 4.8x19 (8)      ST 2.9x19 (2)      ST 4.8x38 (4)</p> <p><b>CAUTION:</b> Hand-tighten screws only. Do <b>not</b> use power tools.</p>	

**ADDITIONAL TOOLS REQUIRED**

- 2mm Allen key (included in hardware kit)
- 5mm Allen key
- #2 Phillips screwdriver

**CAUTION:** Always check that screws used to attach components to the work surface are not too long for the thickness of the surface.

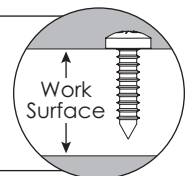

**STEP 1**

With the table top facing down on a soft, clean surface, arrange the cross channels and top supports as shown.

- Positioning does not need to be exact at this time.
- Mounting tabs on cross channels face inward, toward each other.
- Holes on the top supports are offset to the rear.

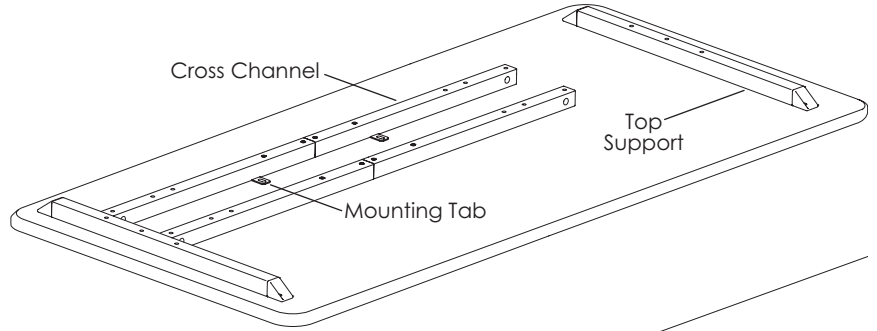
**STEP 2**

Use a 5mm Allen key to loosen the M10 set screws on the cross channels (two on each side of center).

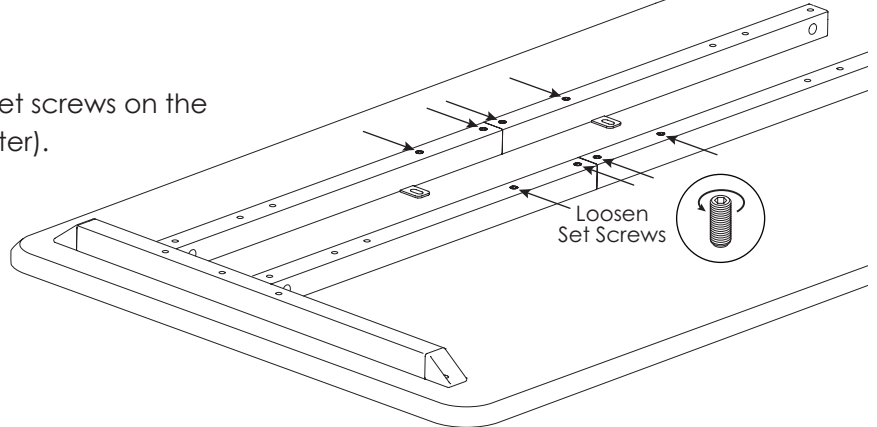
**STEP 3**

Adjust the cross channels to their approximate final lengths, as shown.

- Center the inner piece in each cross channel.

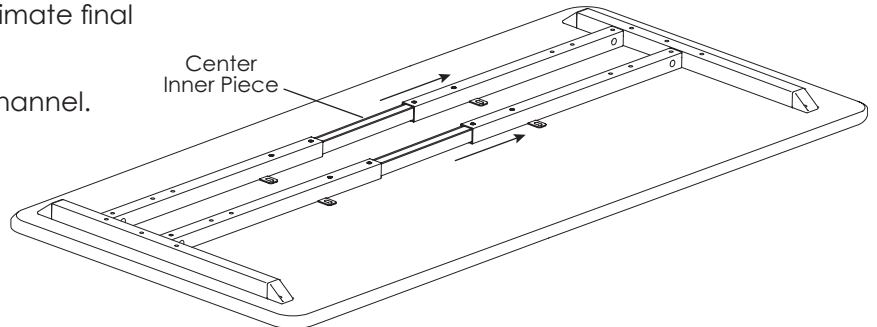
**STEP 4**

Attach the side legs to the cross channels and top supports with six M8x12 screws per leg.

- Use a 5mm Allen key.
- Two screws attach to each cross channel and two screws attach to the top supports.

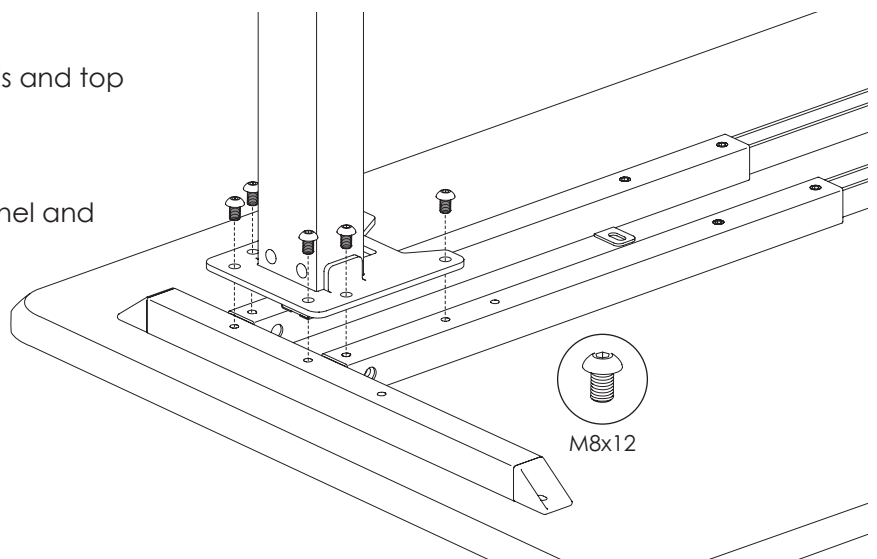

**STEP 5**

Attach a foot plate and foot to each of the side legs with the M6x35 screws.

- First, place the foot plate onto the leg with the smooth side up.
- Position the foot over the foot plate, as shown. The short side of each foot should face the rear.
- Screw the foot securely in position using a 5mm Allen key.

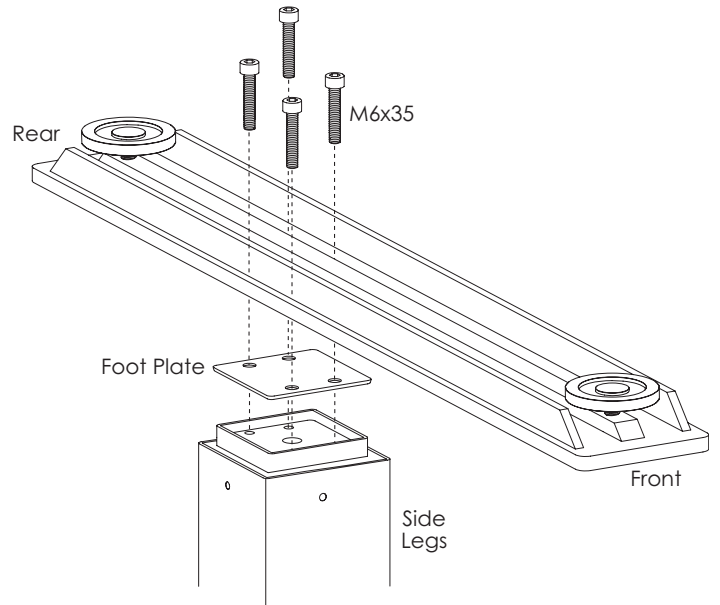

**STEP 6**

Adjust the position of the frame before screwing it to the table.

- The top supports on each side should be approximately 1" (25mm) from the ends of the table.
- The rear of the feet should align with the rear of the table.

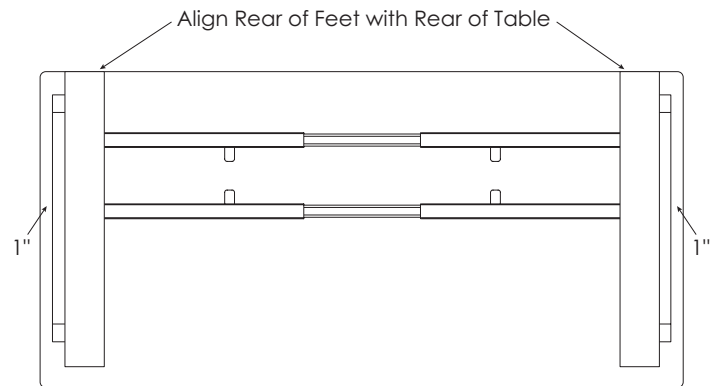

**STEP 7**

Once in their final position, attach the top supports and cross channels to the table.

- Use ST4.8x19 screws (8 total required).
- Attach the screws through the mounting tabs on the cross channels and through the holes at the ends of the two top supports.

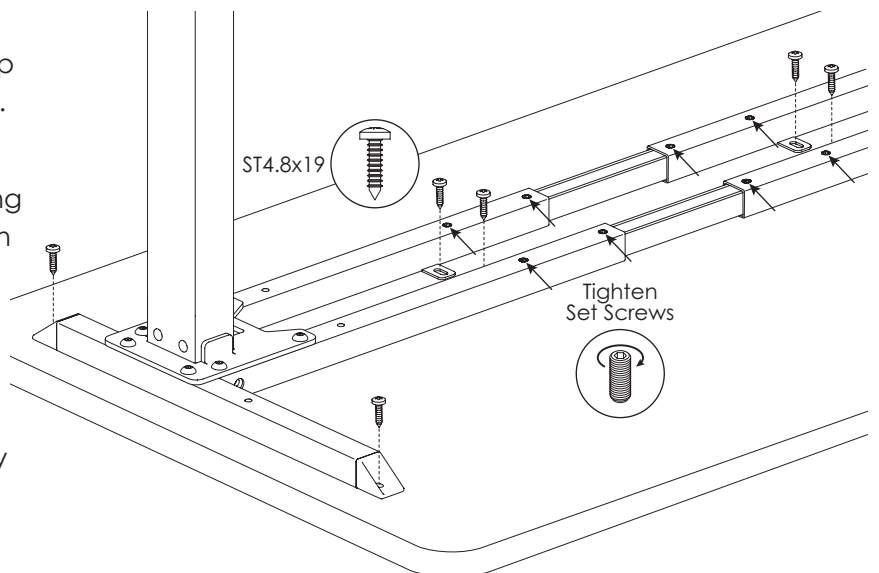

**STEP 8**

Tighten the M10 set screws in the cross channels (8 total). Use the 5mm Allen key to hand tighten.

**STEP 9**

Use a 2mm Allen key to loosen the set screws on each end of the gear connector's outer cylinder.

- This will allow you to adjust the length of the gear connector shaft so that you can insert the shaft into gear drive of the two legs.

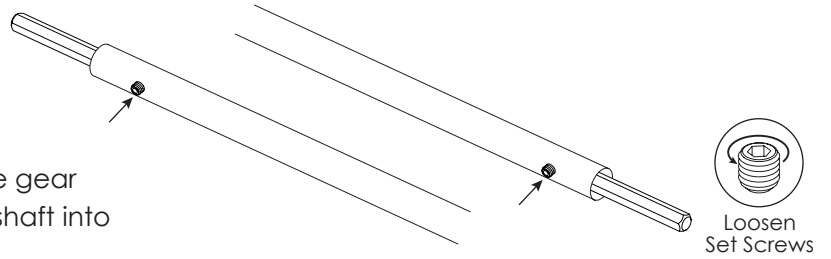

**STEP 10**

Center the outer cylinder of the gear connector between the two legs. Then extend the inner shaft on each side to insert the ends into the gear drive.

- Fully insert the shaft ends until they reach the stop.
- After inserting the shaft, tighten the set screw at each end.
- Check that the gear connector is securely installed. There should be minimal play from side to side.

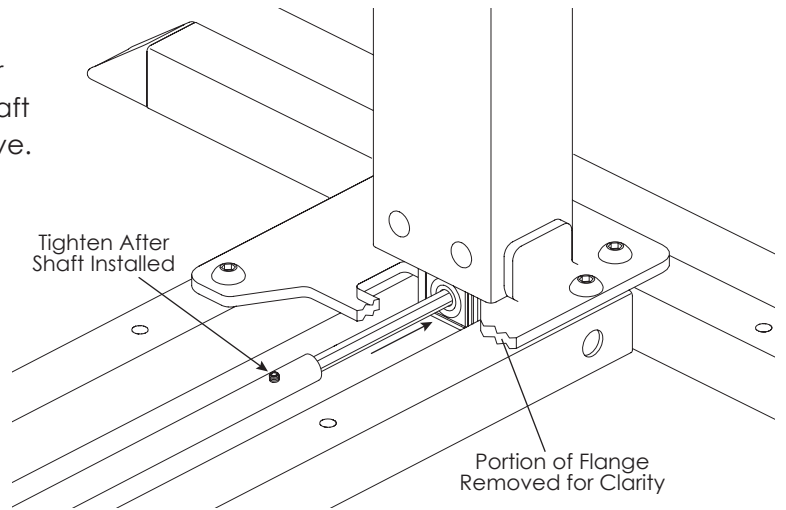

**STEP 11**

Prepare to install the crank handle by loosening the set screw in the outer cylinder.

- The inner shaft of the handle is available in three lengths: 7" (17.8 cm), 10½" (26.7 cm), and 14" (35.6 cm).
- The 7" shaft is pre-installed. The other shafts may be substituted if table width requires (see next step).

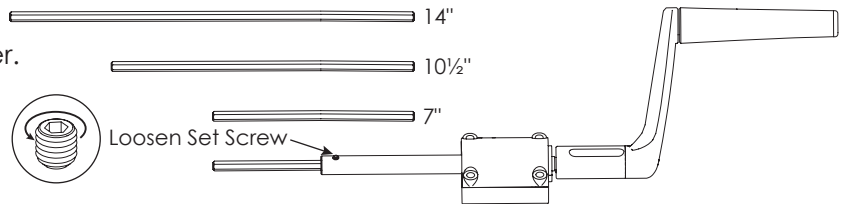

**STEP 12**

Position the shaft and crank handle. The handle may be installed on either the left or right side of the table.

- Fold the crank handle as shown.
- Insert the shaft through the hole in the cross channel to engage it into the gear drive in the base of the leg.
- Choose the correct shaft length so that there is 2<sup>3</sup>/<sub>16</sub>" (55 mm) between the edge of the table and the outer edge of the crank handle gearbox.
- A minimum shaft length of 1" (25mm) must remain in the outer cylinder.

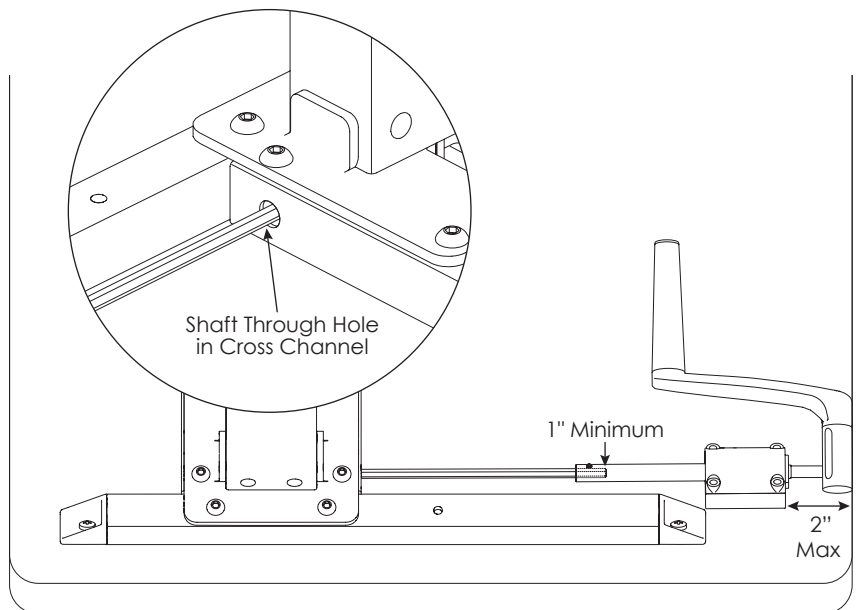

**STEP 13**

Complete crank handle installation.

- Attach the crank handle gearbox with four ST4.8x38 screws.
- Attach the crank handle bracket with two ST2.9x19 screws. The bracket holds the handle under the table when not in use.
- Check that the shaft is fully inserted against the stop inside the base of the leg. Then tighten the set screw on the outer cylinder.

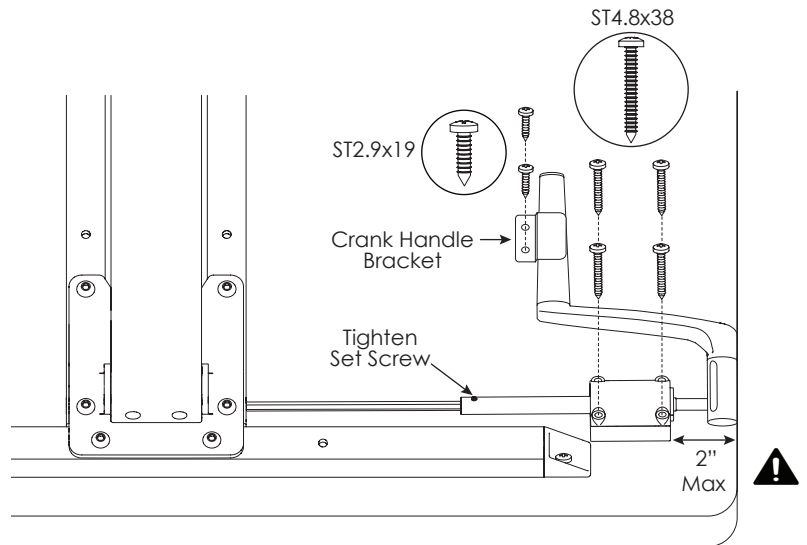

**STEP 14**

With the assistance of a helper, turn the table upright and place it in its final position.

**IMPORTANT:** There must be 1" (25mm) of clearance on all sides of the work surface (and other moving parts) to ensure free, unobstructed movement.

- Adjust the leveling glides on the feet to level the work surface, if necessary.

**STEP 15**

Move the crank handle to its operating position and test operation.

- Turning the handle clockwise raises the table. Turning the handle counter-clockwise lowers it.
- If there are problems with operation, check that all shaft ends are securely inserted. If problems continue, call ESI Customer Service.

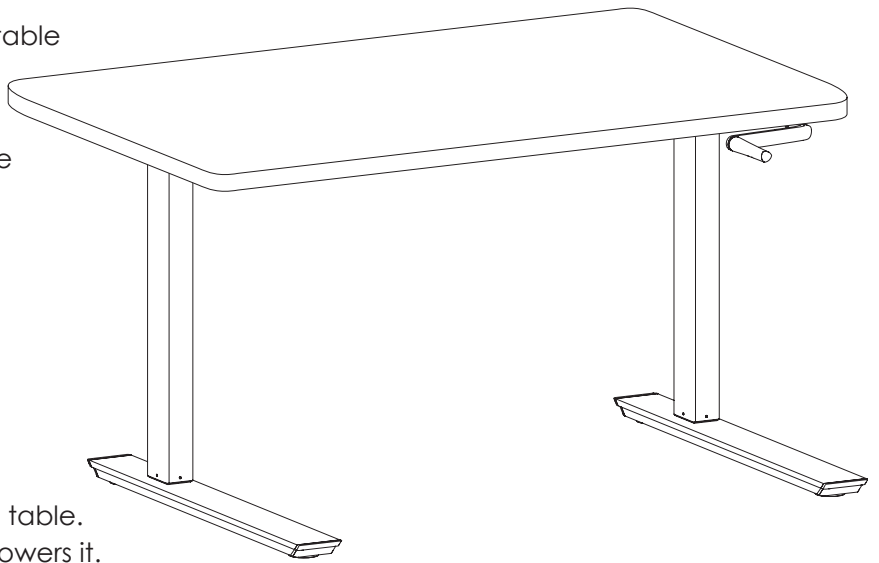

**OPERATION**

When not in use, the crank handle is typically hidden under the work surface, held in place by the crank handle bracket.

- ① To use the crank to operate the table, pull the handle out slightly and rotate it 90° to its operating position.
- ② Push handle inward to engage the crank mechanism
- ③ Turn the handle clockwise to raise the table.
- ④ Turn the handle counter-clockwise to lower the table.
- ⑤ To return the handle to its stowed position reverse the order of assembly: ③ → ② → ①
- ⑥ Always position the handle under the table when not in use to avoid accidental contact. Pull the handle out slightly and "fold" it under the the table. Push in the handle to secure it in the crank handle bracket.

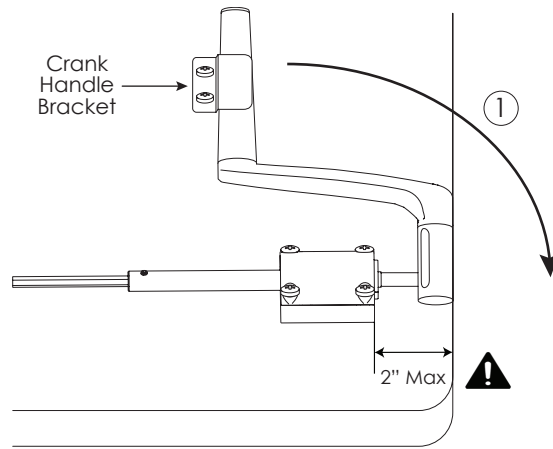

Bottom View of Work Surface

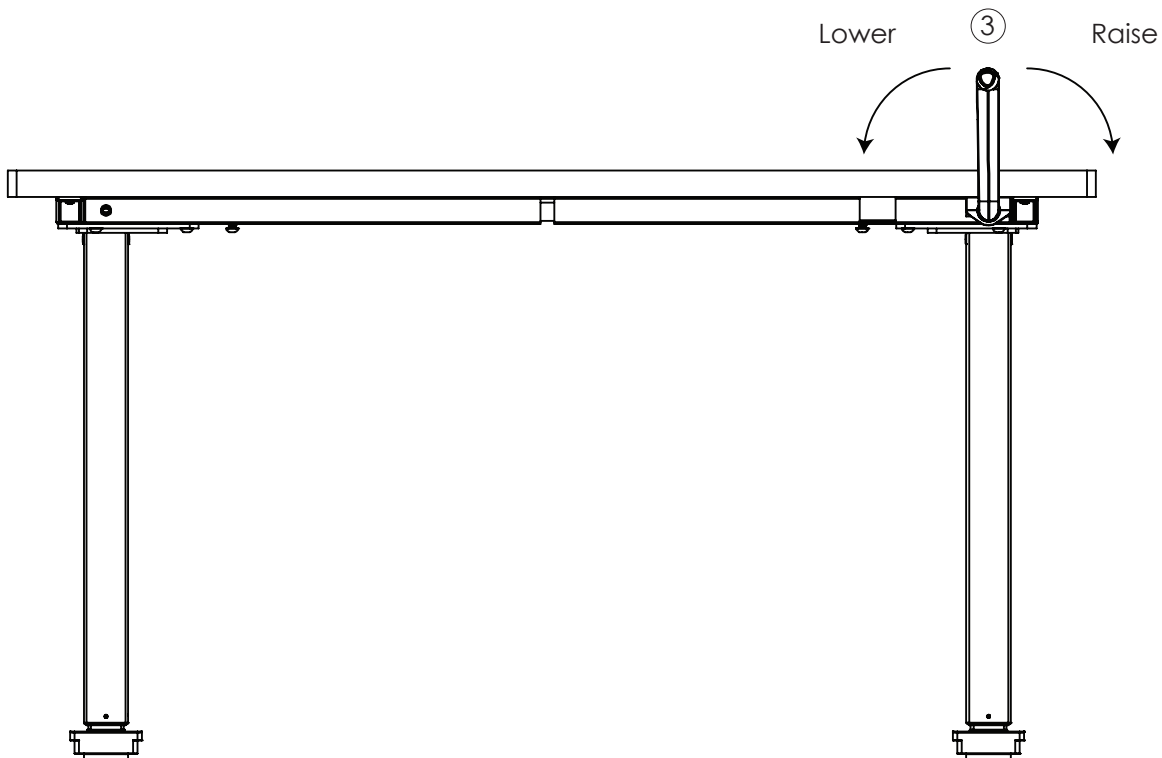
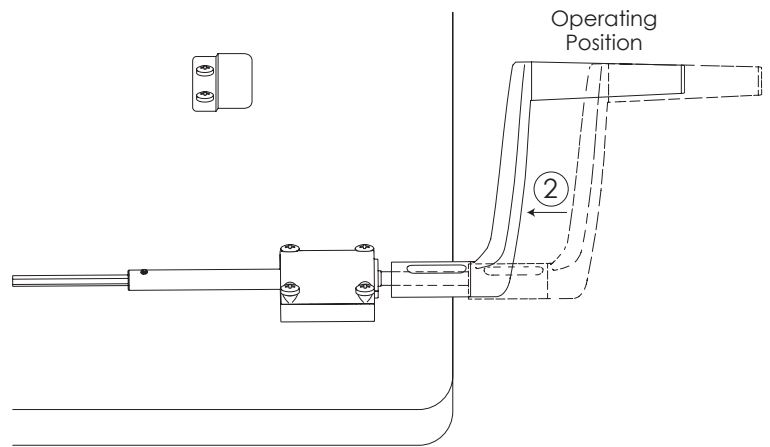



800.833.3746 | [esiergo.com](http://esiergo.com)