

esi

assembly and operation instructions

Lotus™ RT

sit-stand workstation

Model #'s

LOTUS-RT1-BLK

LOTUS-RT1-WHT

LOTUS-RT2-BLK

LOTUS-RT2-WHT

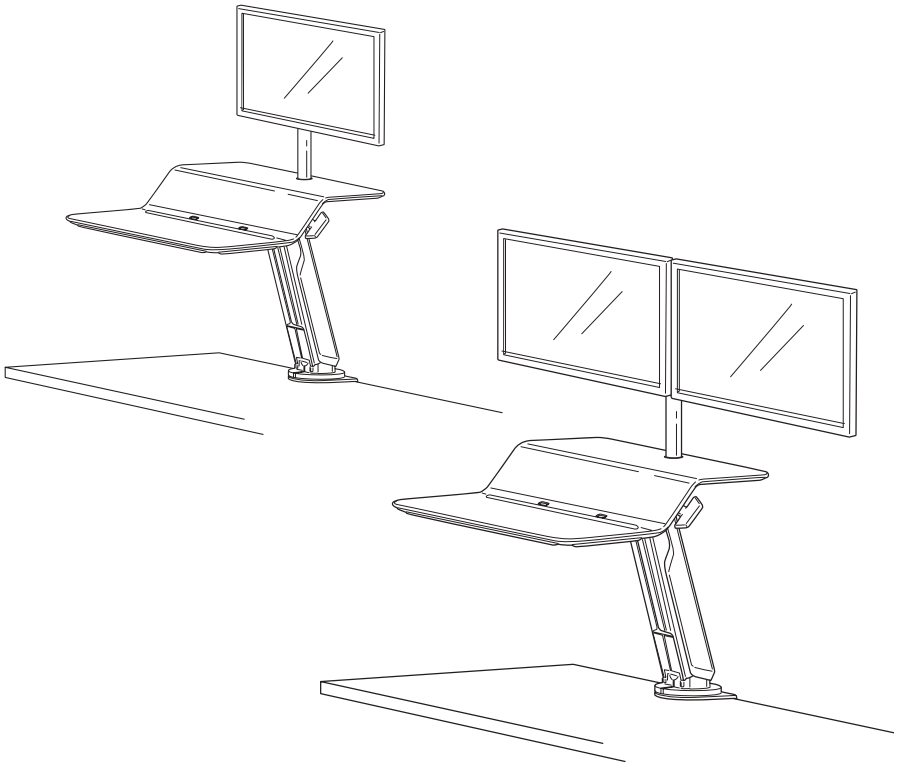



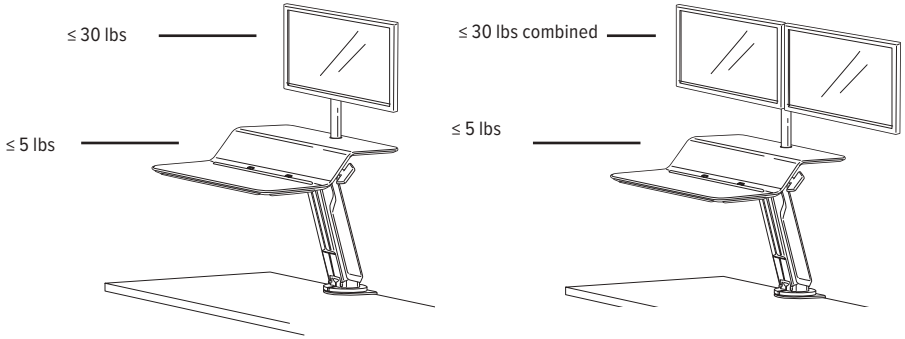

Safety instructions/warning

Read and follow all instructions and warning before use.

- Ensure that the sit stand is anchored tightly to the desk/table before using it to prevent injury or damage to the product.
- **WARNING: PINCH POINT! KEEP HANDS CLEAR OF SUPPORT BARS DURING OPERATION. SERIOUS INJURY MAY OCCUR.**
- **WARNING: DO NOT EXCEED MAXIMUM STATED WEIGHT CAPACITY. SERIOUS INJURY OR PROPERTY DAMAGE MAY OCCUR.**
- **CAUTION: LIFT HAZARD! TWO PEOPLE ARE REQUIRED TO MOVE THE WORKSTATION. SERIOUS INJURY OR PROPERTY DAMAGE MAY OCCUR.**
- Ensure cable lengths are long enough and follow the cable routing instruction in this manual. Failure to follow these instructions may result in equipment damage or personal injury.
- **DO NOT** adjust tension setting until all equipment and accessories have been placed on the workstation.
- **DO NOT** lean on the keyboard platform.
- Only compatible with Fellowes monitor arm kit for Lotus.
- Make sure the desk or mounting surface is level and can support the combined weight of the workstation and accessories.
- Remove all equipment and accessories from the workstation before moving.
- Not for use with glass surfaces.
- Maximum desk thickness: 3.0" (76mm) / minimum desk thickness 3/4" (19mm)



parts provided

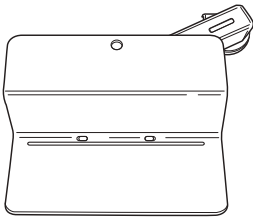
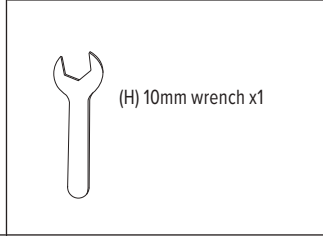
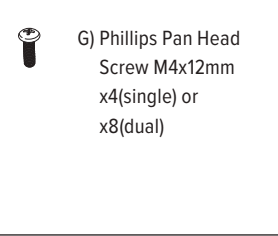
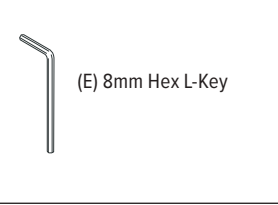
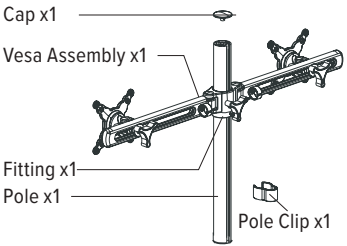
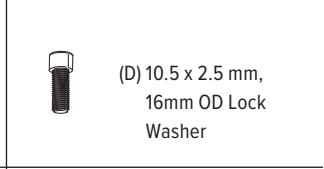
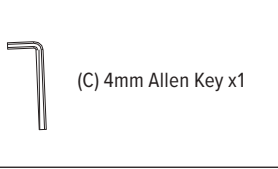
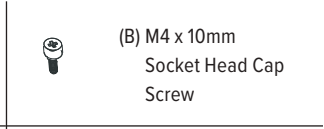
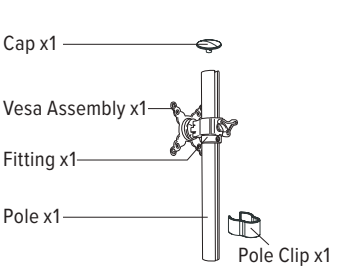

Base + Workstation x1

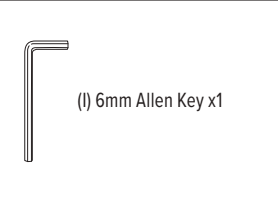

Clamp Support Plate x1

step 1a: Clamp install for thicker worksurfaces

- The clamp comes assembled to accommodate tables up to $1\frac{5}{8}$ " (41.27mm) thick and requires $3\frac{13}{16}$ " (96.52mm) of clearance behind the desk. If your table is thicker than $1\frac{5}{8}$ ", continue with Step 1a. If your desk is close to a wall and has limited space, $\frac{1}{4}$ " to $3\frac{13}{16}$ " (6.35mm to 96.4mm), move to step 1b. If neither apply, move to step 1c.
- Use two people to lift the base and worksurface out of the box. (Image A)
- On the clamp, loosen one screw and remove the other using the 4mm Allen Key (C). (Image B)
- Slide the clamp off to change the orientation. Slide the clamp back on as shown in Image C.
- Re-install screw and tighten the other screw. Ensure both screws are securely fastened. Move to step 1b.

Image A

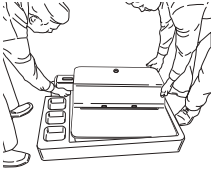

Image B

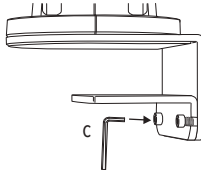
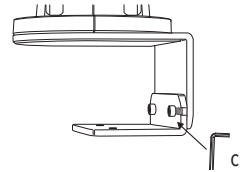

Image C



step 1b: clamp install with thin worksurface

- Use two people to lift the base and worksurface out of the box. (Image D)
- Remove the clamp using the 4mm Allen Key (C). (Image E)
- Place on the rear of the desk and re-install the clamp underneath the desk. Move to step 1c. (Image F)

Image D

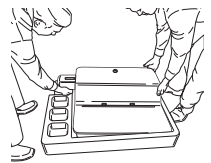

Image E

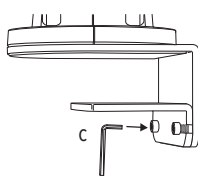
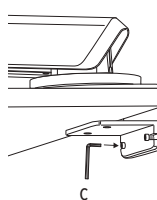

Image F





step 1c

Unbox and determine sitting height position

- Use two people to lift the base and worksurface out of the box. (Image A)
- Carefully place the base and worksurface onto the table. (Image B)
- Determine your desired sitting position. (Image C)
Note: If your desired sitting position is in the center of the table, choose a base mounting position that is offset from the center (Image D).

Image A

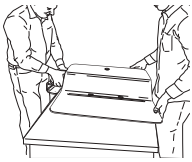

Image B

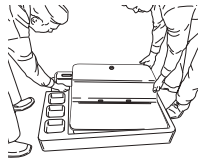

Image C

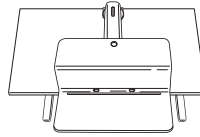
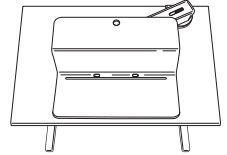

Image D



step 2

Clamp

- Insert two M8 screws (J) into the clamp. (Image E)
- Place the clamp support plate on top of the M8 screw (I). Ensure the tip of the screws align to the holes in the clamp support plate. (Image F)
- Tighten the M8 screws (J) with the 6mm Allen Key (I) until the clamp support plate is secured to the desk.

Image E

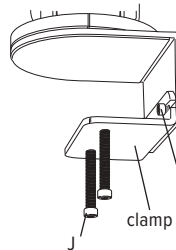
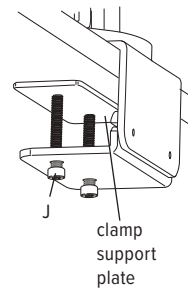

Image F



step 3

- Remove the zip tie from the lever on the right side of the platform. May require the use of scissors (Image G)
- Engage the lever and raise the workstation.
- (Optional) If you'd like the lever on the left side of the platform, remove the (2) M6x10mm bolts holding the handle with the 4mm Allen Key (C). Re-attach to the left side. (Image H)

Image G

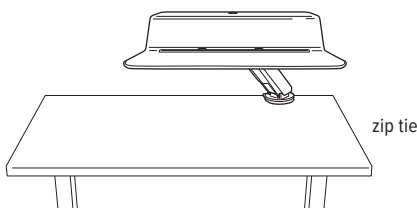
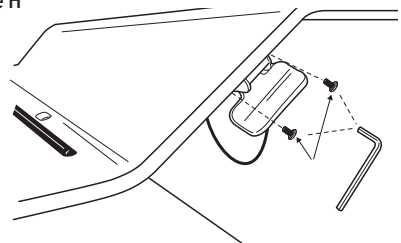

Image H



step 4a

Attach monitor arm

- Install monitor pole by placing it into the cutout on the platform. (Image A)
- Insert the M10 screw (D) with lock washer (A) through the underside of the platform.
- Tighten the M10 screw (D) using 8mm Hex L-Key (E). (Image B)
- Engage the lever and lower the worksurface to the desk.

Image A

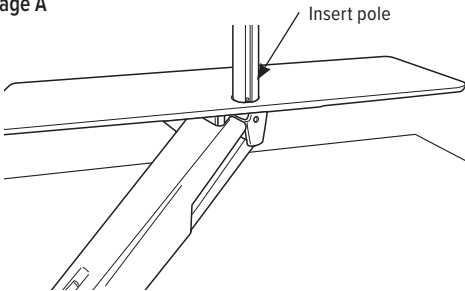
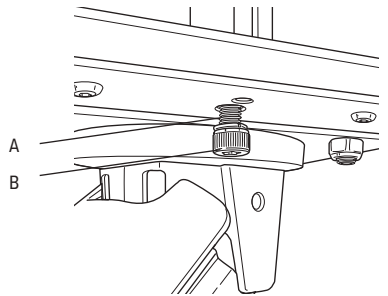

Image B



step 4b

Attach monitor arm

- Attach the fitting to the monitor pole and adjust the fitting to the desired height. Tighten the fitting to the pole using a Phillips screw driver. (Image C).
- Slide the VESA assembly onto the monitor pole and tighten using the knob on the rear (Images D–F).
- Insert cap onto top of pole and secure using M4 screw (B) and 4mm Allen Key (C).

Image C

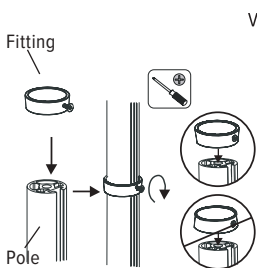

Image D

Single monitor arm

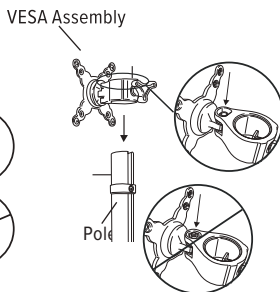

Image E

Dual monitor arm

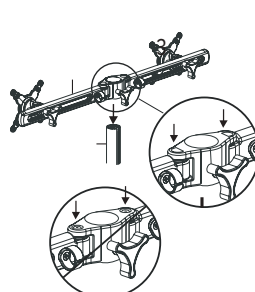
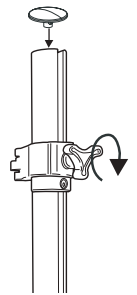

Image F





step 5

Attach Monitor(s)

- Attach your monitor(s) to the VESA assembly using the included Phillips pan head screws M5x12mm (F) or M4x12mm (G), depending on your monitor.

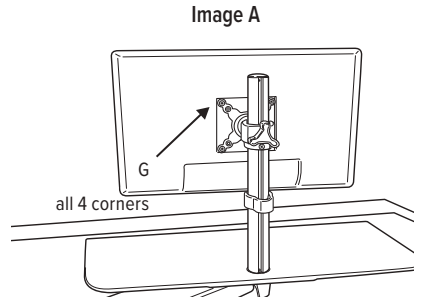

step 6 (optional)

Adjust platform level

- Activate lever and move unit to desired sitting position (image B).
- The worksurface is assembled to be level, however certain setups may show lifting of the corners (Image C). In order to adjust the surface, follow the steps below.
 - Determine if the left or right side is lifting up.
 - Engage the lever and raise the worksurface.
 - On the lower side of the surface, loosen the (2) M6 nuts on the underside of the platform using a 10mm wrench (H).
 - On the same side, tighten the M4 adjustment screw (image E) using the 4MM Allen Key (C) until the worksurface is level.
 - Re-tighten the two M6 nuts.
 - Lower the worksurface back to the sitting position. If the surface is not to the desired setting, repeat steps above until surface is level.

Image B

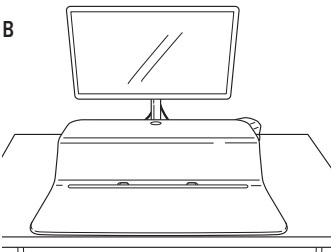

Image C

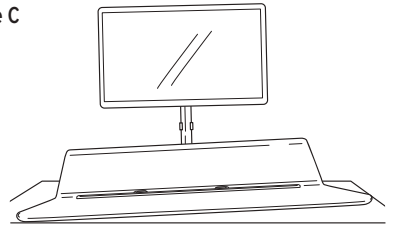

Image D

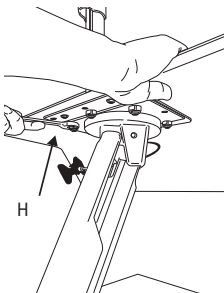
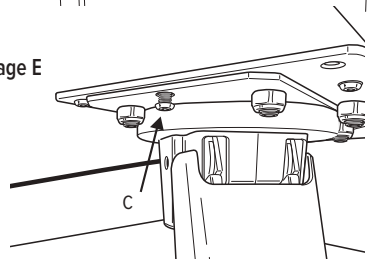

Image E





step 7

Cord management

- Ensure the workstation is raised to the highest position.
- Route the keyboard and mouse cords through the holes in the worksurface. (Image A)
- Route the monitor cords down the pole and clip with included cord clip. (Image B)
- Continue routing monitor cords down through the cord funnel at the rear of the platform. (Image C)
- Gather all cords underneath platform and route through the arm to the base.
- Ensure proper cord length for desired range of motion.

Image A

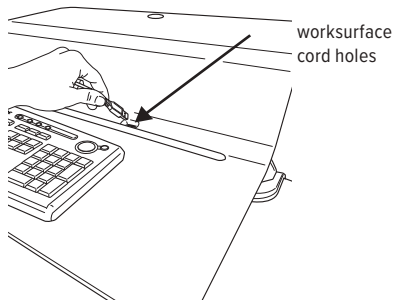

Image B

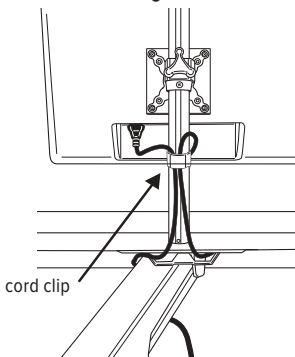
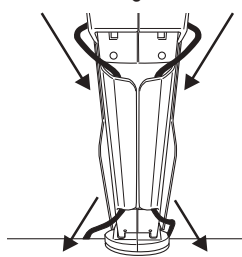

Image C





step 8

Tension adjustment

- Adjustable tension makes it effortless to raise and lower the workstation. Start by raising the workstation to the highest position with all equipment and accessories placed on the workstation.
- Lotus RT is shipped at the lightest tension setting. Turn the bolt located at the rear of the base counter clockwise using the 6mm Allen Key (I), to offset heavier weights. As a guideline, approximately 10 half turns are needed to offset a single monitor setup, 25 half turns for a dual monitor setup. The exact number of rotations depends on your personal comfort. Once you have properly adjusted the Lotus RT, it should feel effortless to raise and lower.

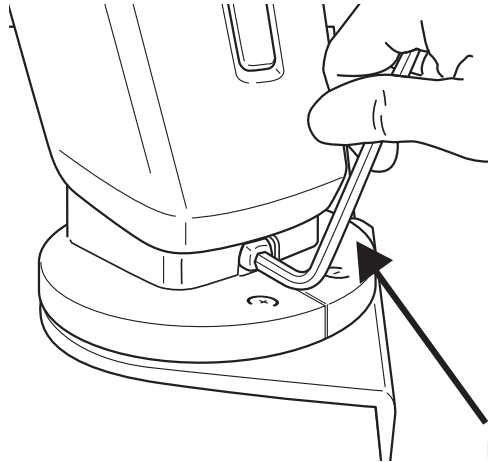



recommended usage

Start by standing for 15 minutes each hour. Adjust based on what is comfortable for you.

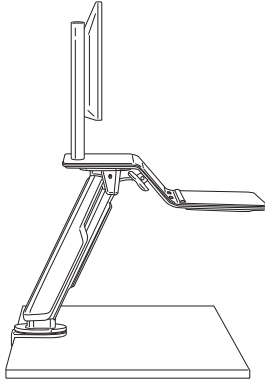

15

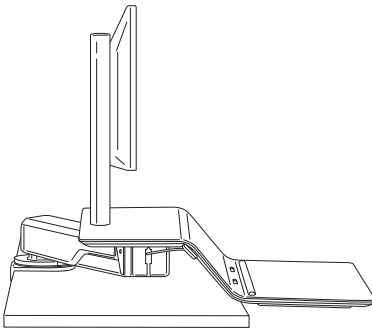

45





Lotus™ RT

sit-stand workstation

Please contact Customer Service with any questions or comments at 800.833.3746 or visit our website at esiergo.com

ESI LOTUS™ RT 5 YEAR LIMITED WARRANTY

ESI (the "Company") warrants the Lotus™ RT ("Product") to be free from defects in material and workmanship appearing within five (5) years from the date of the original purchase of the product. If such a defect appears during the warranty period, the Company will (at its sole option) either repair or replace the defective product with no charge for service or parts or refund the purchase price.

This warranty applies only to the initial retail purchaser and does not cover claims resulting from misuse, failure to follow instructions on installation and use, neglect, use of unauthorized attachments, commercial use, use on a current or voltage other than specified on the product, or unauthorized service during the warranty period on conditions otherwise covered by warranty.

THE DURATION OF ANY IMPLIED WARRANTIES, INCLUDING BUT NOT LIMITED TO ANY IMPLIED WARRANTIES OF MERCHANTABILITY OR FITNESS FOR A PARTICULAR PURPOSE, IS EXPRESSLY LIMITED TO THE DURATION OF THIS LIMITED WARRANTY.

UNLESS REQUIRED BY APPLICABLE LAW, THE CUSTOMER'S EXCLUSIVE REMEDY FOR BREACH OF THIS WARRANTY OR ANY IMPLIED WARRANTY OR OF ANY OTHER OBLIGATION ARISING BY OPERATION OF LAW OR OTHERWISE SHALL BE LIMITED AS SPECIFIED HEREIN TO REPAIR, REPLACEMENT OR A REFUND OF THE PURCHASE PRICE, AT THE COMPANY'S SOLE OPTION.

UNDER NO CIRCUMSTANCE WILL THE COMPANY, ITS AFFILIATES, SUBSIDIARIES, RELATED ENTITIES, RESELLERS OR THEIR RESPECTIVE OFFICERS, DIRECTORS OR EMPLOYEES OR THOSE PERSONS FOR WHOM THEY ARE BY LAW RESPONSIBLE, BE LIABLE FOR CONSEQUENTIAL OR INCIDENTAL DAMAGES SUBSTAINED IN CONNECTION WITH THE PRODUCT. THE COMPANY AND THESE OTHER PARTIES DO NOT ASSUME OR AUTHORIZE ANY REPRESENTATIVE OR OTHER PERSON TO ASSUME FOR ANY OF THEM ANY OBLIGATION OR LIABILITY OTHER THAN AS IS EXPRESSLY SET FORTH HEREIN.

The duration, terms and conditions of this warranty are valid worldwide, except where different limitations, restrictions or conditions may be required by local law.

To make a warranty claim, contact ESI at 800-833-3746 or customerservice@esiergo.com. You must provide proof of purchase, such as the original purchase order number.