

esi

universal assembly guide

Kata™ EX

monitor arm series

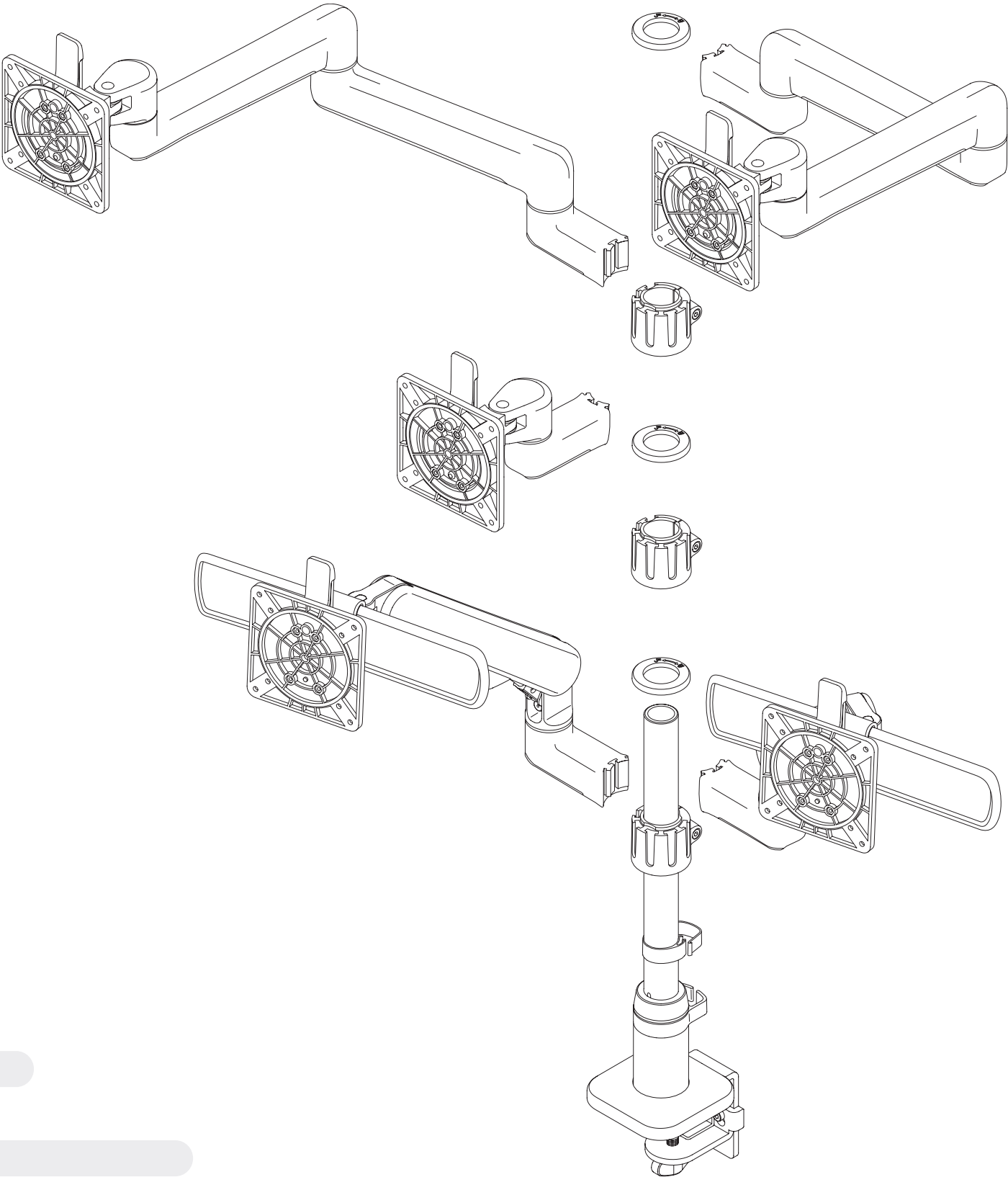



Contents

Understanding the model number 2
 Components 3
 Configurations 5
 Assembly steps 9
 Adjustments 18

Configurations

The Configurations section shows illustrations of the four basic monitor arm types: fixed, motion, fixed+fixed, and fixed+motion. Variations within each type include the number of monitor arms and if a slider mount is used. See the model number explanation at the bottom of this page.

FF (fixed+fixed)

KataEX1-FF 7
 KataEX2-FF 7
 KataEX3-FF 7
 KataEX4-FF 7
 KataEX6-FF 7

FM (fixed+motion) and FMS (fixed+motion slider)

KataEX1-FM 8
 KataEX2-FM 8
 KataEX2-FMS 8
 KataEX3-FMS 8
 KataEX4-FM 8
 KataEX4-FMS 8
 KataEX6-FMS 8

F (fixed), FS (fixed slider) and ST (stem mount)

KataEX1-F 5
 KataEX1-ST 5
 KataEX2-F 5
 KataEX2-FS 5

M (motion) and MS (motion slider)

KataEX1-M 6
 KataEX1-MS 6
 KataEX2-M 6
 KataEX2-MS 6
 KataEX4-MS 6



CAUTION

- Hand tighten screws only. Do not use power tools.
- Do not position the monitors behind the mounting location of the base.
- If the monitor arm is installed on a desk or table with open space behind the arms, it is recommended to install the 180° lockout screws.

Understanding the model number

The **model number** provides complete information about the configuration of a KataEX system. We'll use the model number **KATAEX2-DC-FMS-SLV** as an example.

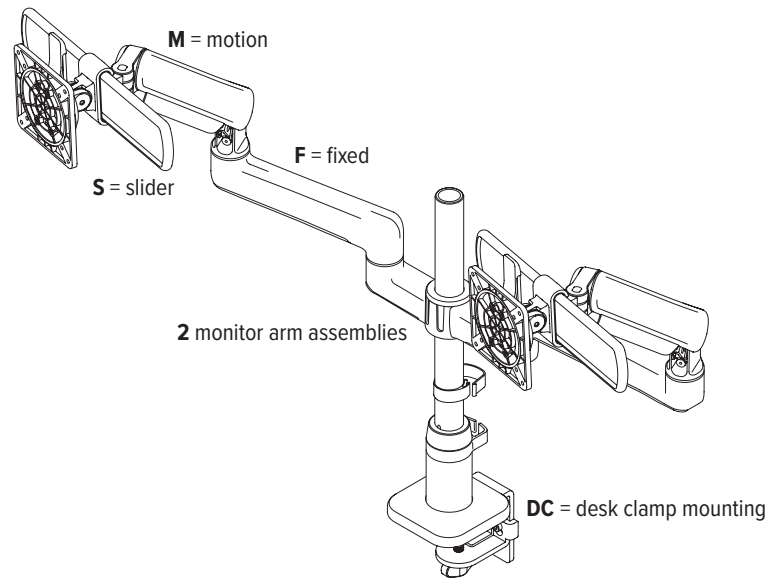
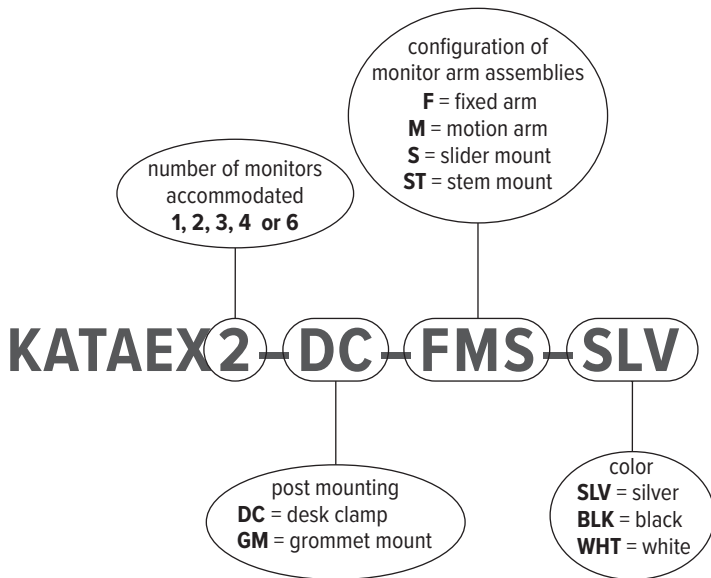



Monitor arm assemblies

Shown below are the different types of monitor arm assemblies. With slider mounts, remember that the VESA mount assembly is not pre-installed to the slider on the monitor arm.

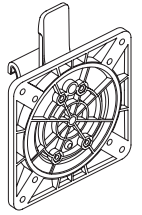

Fixed (F)

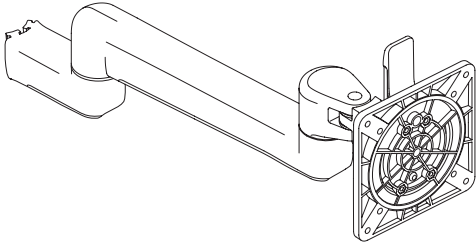

Fixed+Slider (FS)

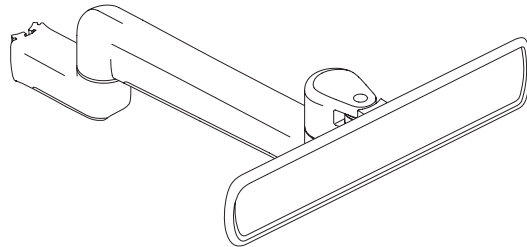

Motion (M)

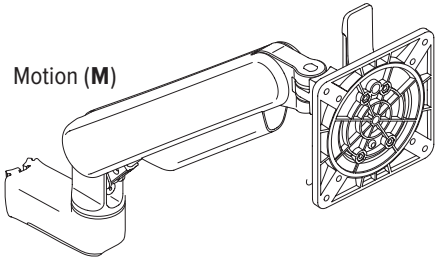

Motion+Slider (MS)

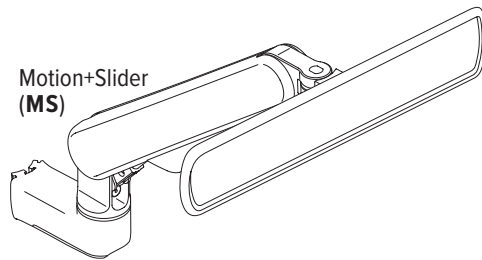

Fixed+Fixed (FF)

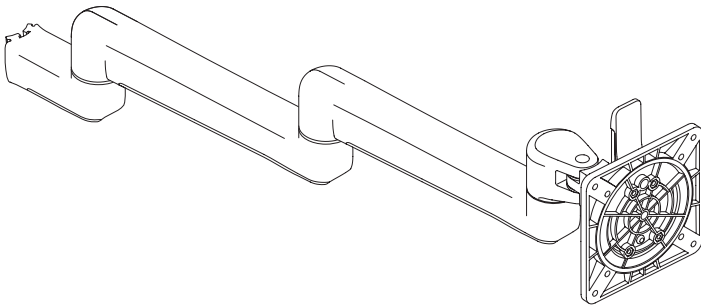

Fixed+Fixed+Slider (FFS)

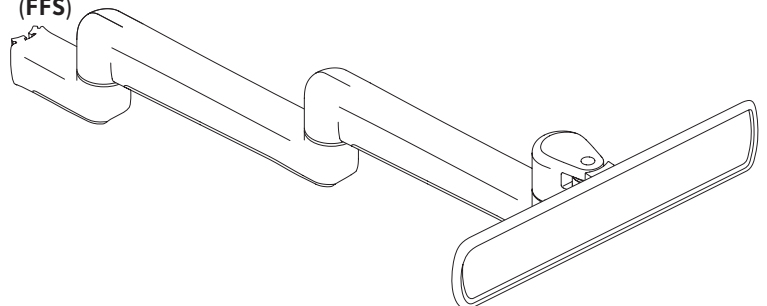

Fixed+Motion (FM)

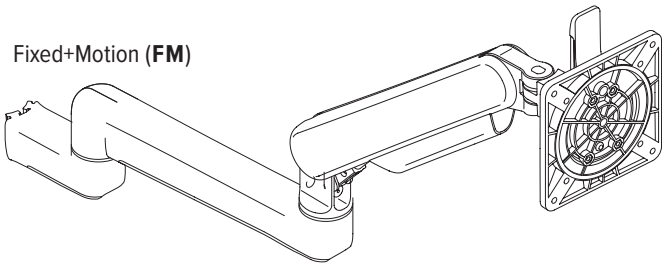

Fixed+Motion+Slider (FMS)

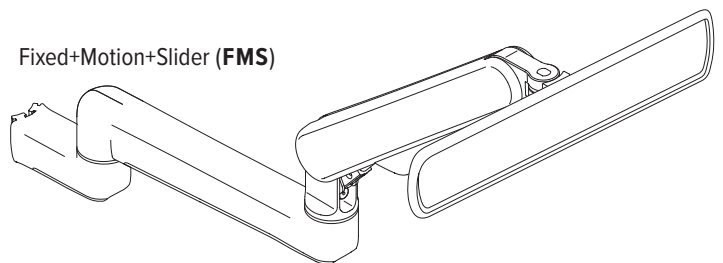

Stem (ST)

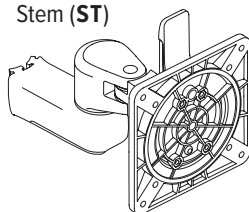



Mounting posts and miscellaneous

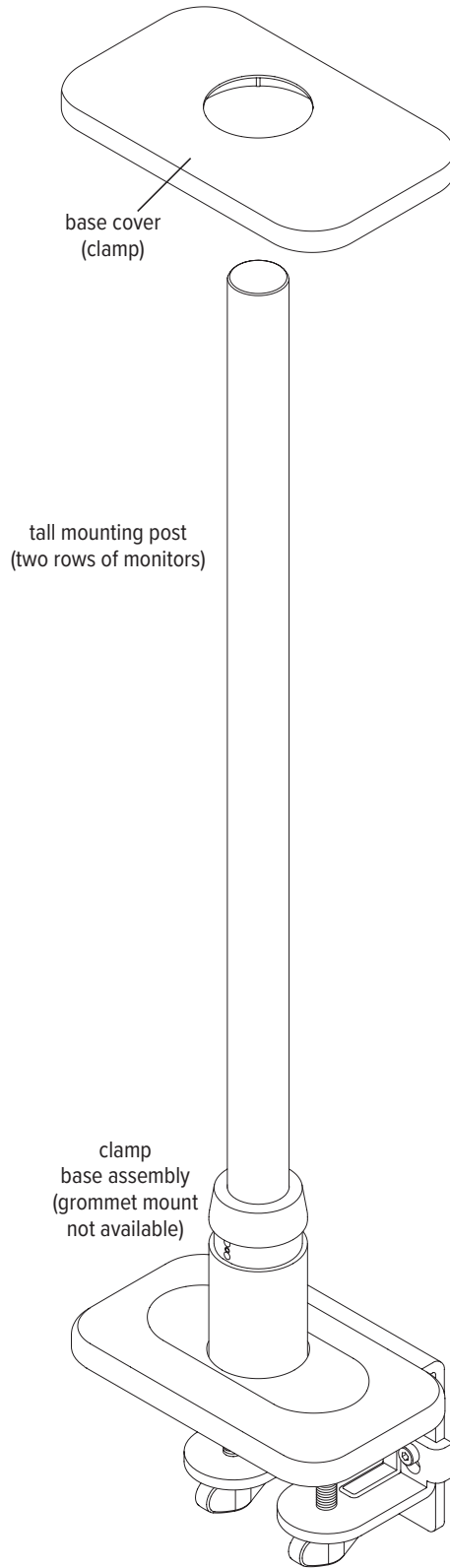
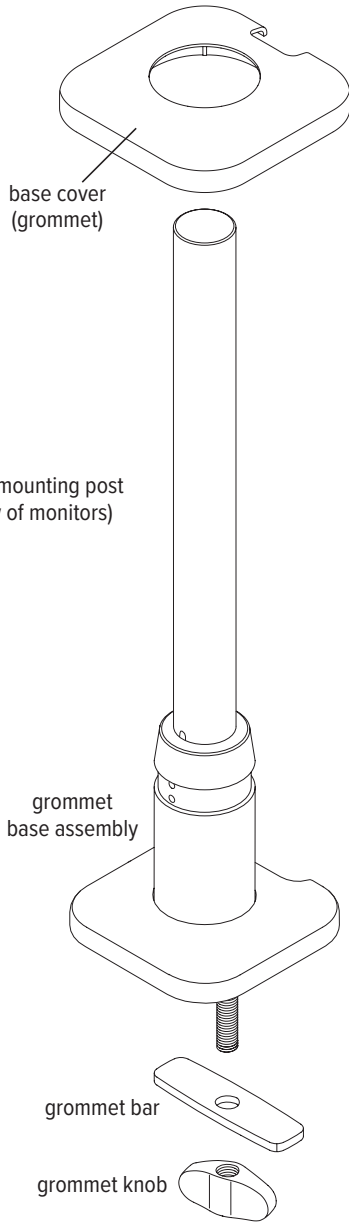
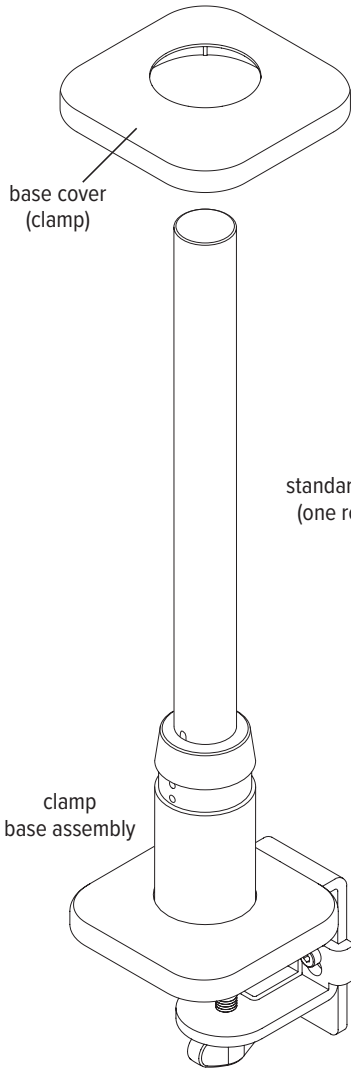

connection sleeve

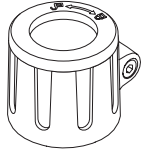

decorative covers (set of 4)

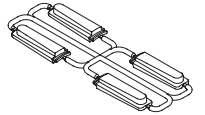

cable clip (post)

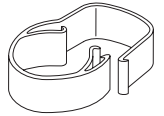

cable clip (base)

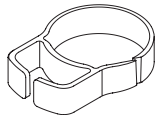

VESA plate screws



M4x10

set screws



M4x15

set screws



M4x9

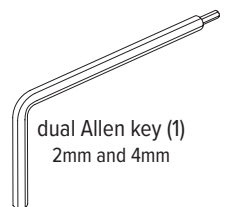

dual Allen key (1)
2mm and 4mm



F (fixed), FS (fixed slider) and ST (stem mount)

The numbers on the illustration below refer to assembly steps. Abbreviated instructions for the steps are shown on the right side of the page. For more detailed instructions, see the assembly steps beginning on page 9.

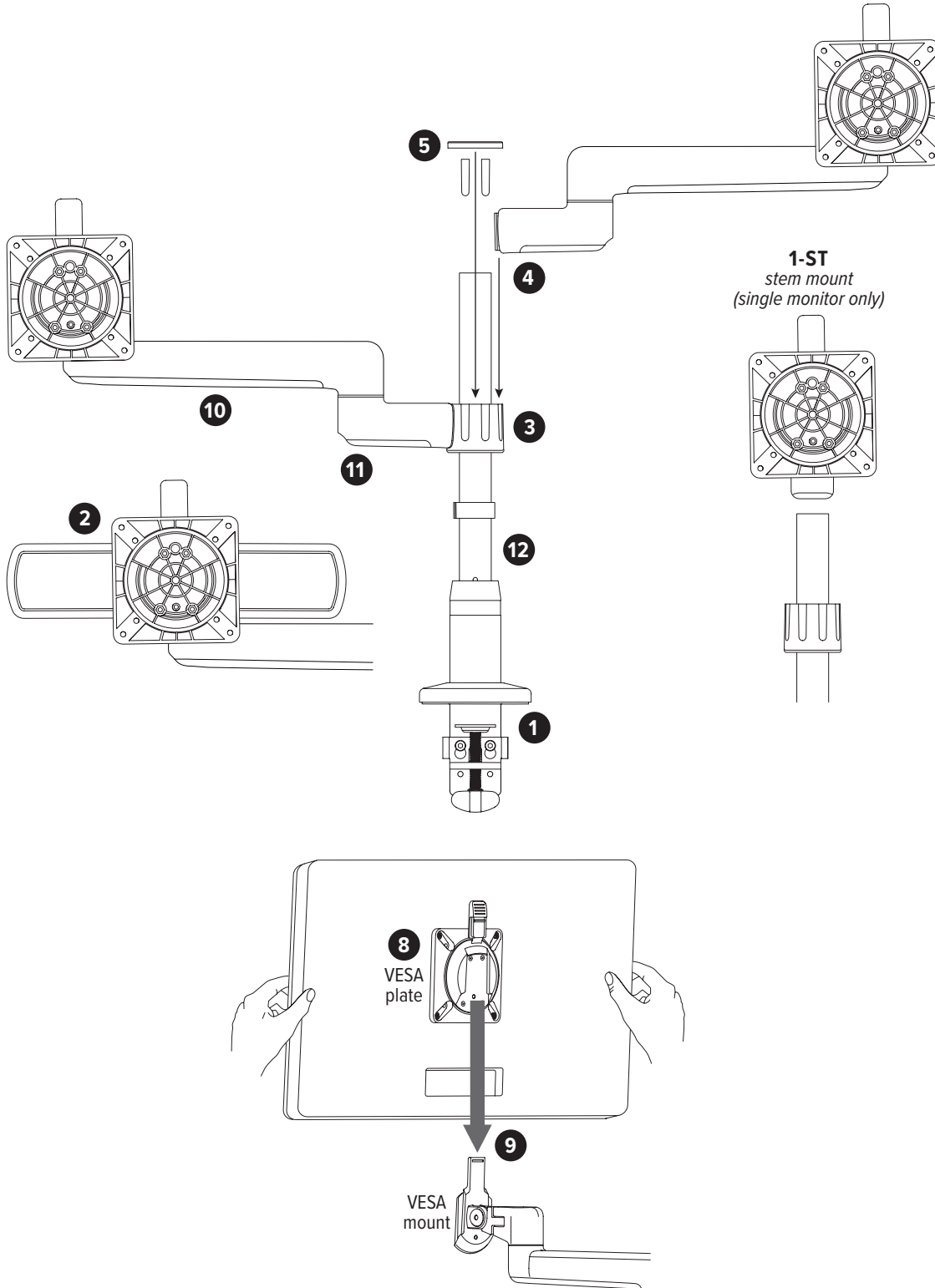

- 1 attach base assembly
- 2 if slider mount — assemble slider mount(s)
- 3 install connection sleeve
- 4 attach up to two monitor arm assemblies
- 5 secure up to two monitor arm assemblies
- 6 if three monitors — NOT APPLICABLE
- 7 if two rows of monitors — NOT APPLICABLE
- 8 attach VESA plate(s) to monitor(s)
- 9 attach monitor(s) to VESA mount(s)
- 10 remove cord management covers
- 11 optional — install lockout set screws
- 12 organize cables and cords
- 13 make any necessary adjustments (see pages 18-19)



M (motion) and MS (motion slider)

The numbers on the illustration below refer to assembly steps. Abbreviated instructions for the steps are shown on the right side of the page. For more detailed instructions, see the assembly steps beginning on page 9.

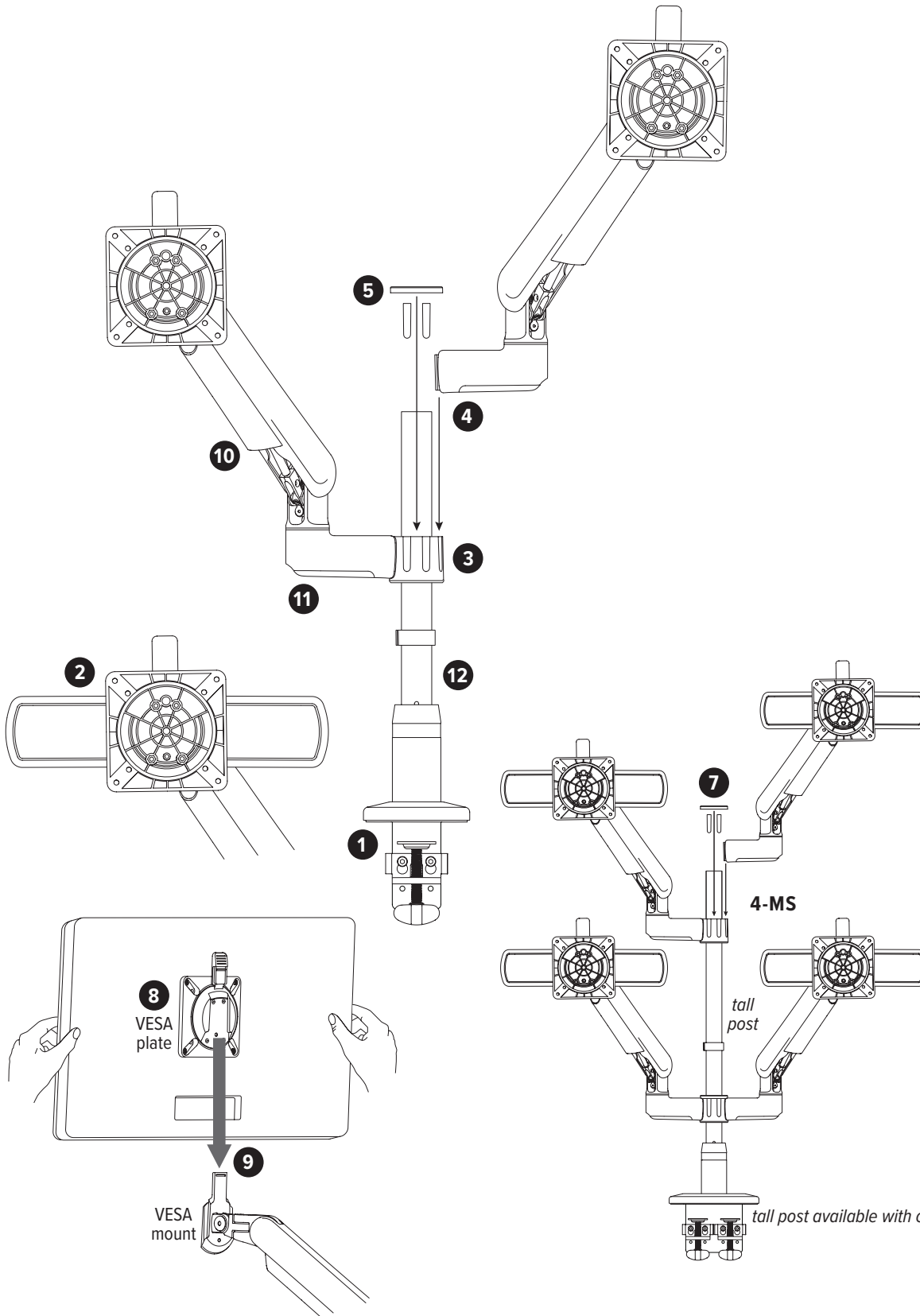

- 1 attach base assembly
- 2 if slider mount — assemble slider mount(s)
- 3 install connection sleeve
- 4 attach up to two monitor arm assemblies
- 5 secure up to two monitor arm assemblies
- 6 if three monitors — NOT APPLICABLE
- 7 if two rows of monitors — repeat steps 3 to 5
- 8 attach VESA plate(s) to monitor(s)
- 9 attach monitor(s) to VESA mount(s)
- 10 remove cord management covers
- 11 optional — install lockout set screws
- 12 organize cables and cords
- 13 make any necessary adjustments (see pages 18-19)

FM (fixed+motion) and FFS (fixed+motion slider)

The numbers on the illustration below refer to assembly steps. Abbreviated instructions for the steps are shown on the right side of the page. For more detailed instructions, see the assembly steps beginning on page 9.

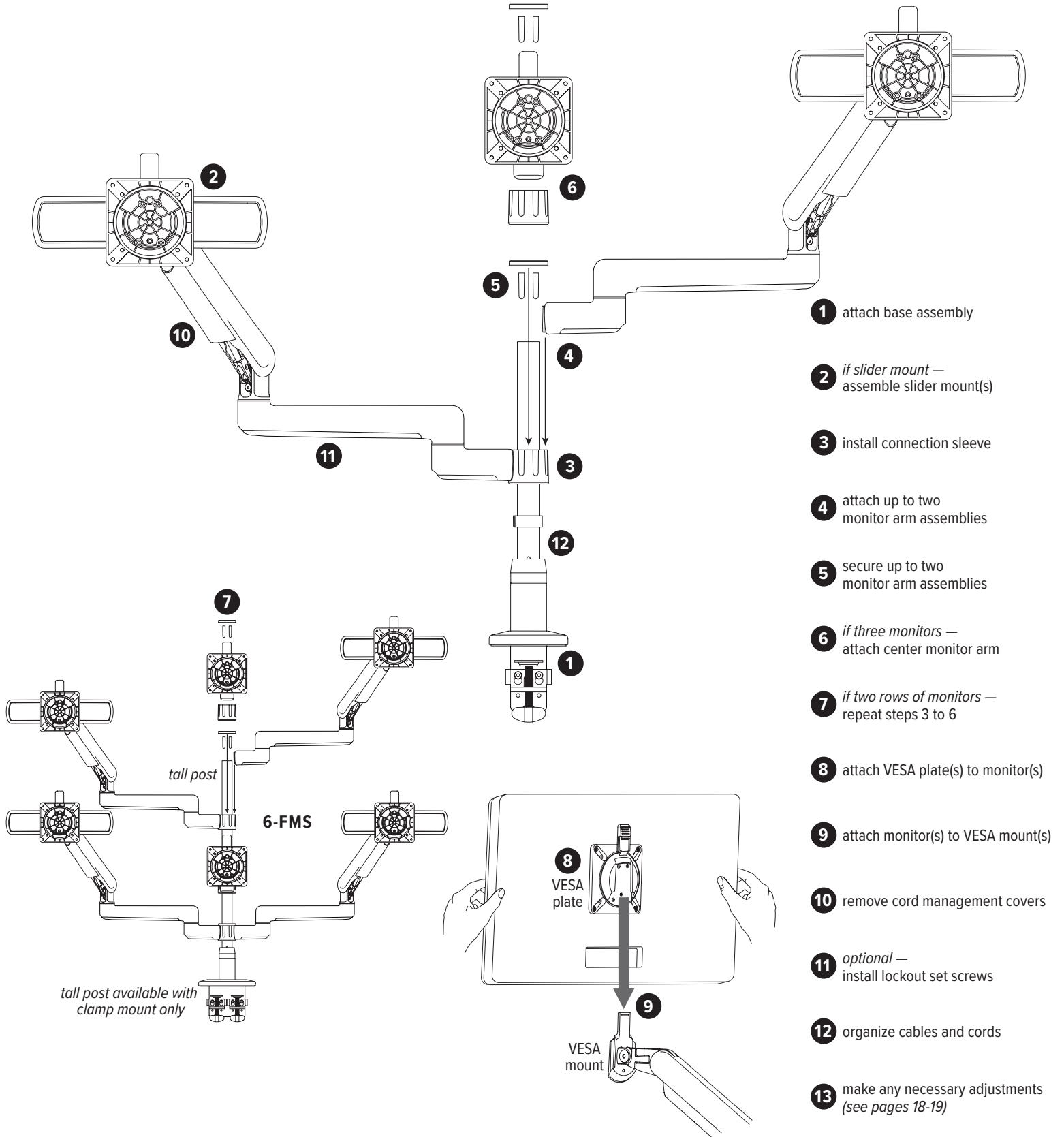

Follow either step #1a for clamp mounting or step #1b for grommet mounting.

Step #1a: attach base assembly to worksurface — clamp mount

With the clamp in the top two holes of the clamp bracket, the thickness of the worksurface must be between 0.5" and 2.1". To mount the rear of the clamp flush against the worksurface, the thickness must be no more than 1.5".

- Loosen the clamp sufficiently to be able to slide it easily onto the worksurface.
- Clamp the assembly to the worksurface in the desired position. Be sure to tighten the clamp securely.

For a table thickness greater than 2.1", secure the clamp to the bottom two holes of the clamp bracket.

- Use the 4mm Allen key to remove the two screws holding the clamp to the bracket.
- Re-install the clamp to the bottom two holes of the bracket.

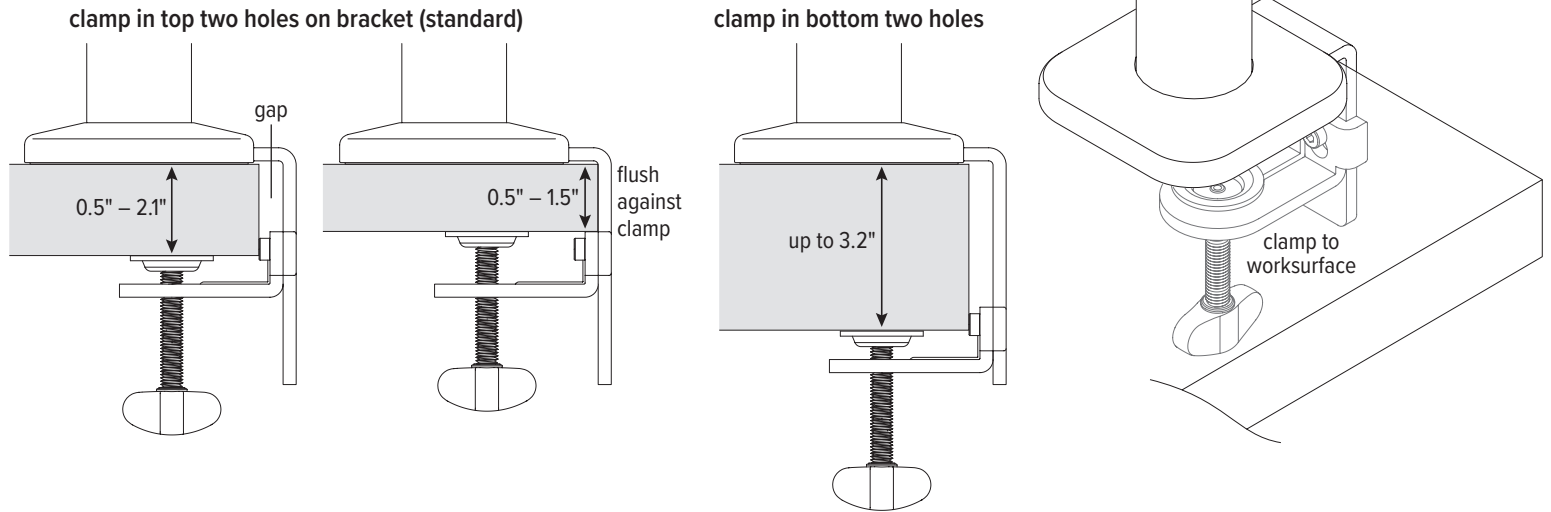

Step #1b: attach base assembly to worksurface — grommet mount

Maximum thickness of the worksurface for grommet mounting is 1.7".

- Place the base assembly over the grommet hole with the bolt centered.
- Insert the grommet bar onto the grommet bolt and then screw on the grommet knob. Tighten the grommet knob securely to hold the base assembly in position.

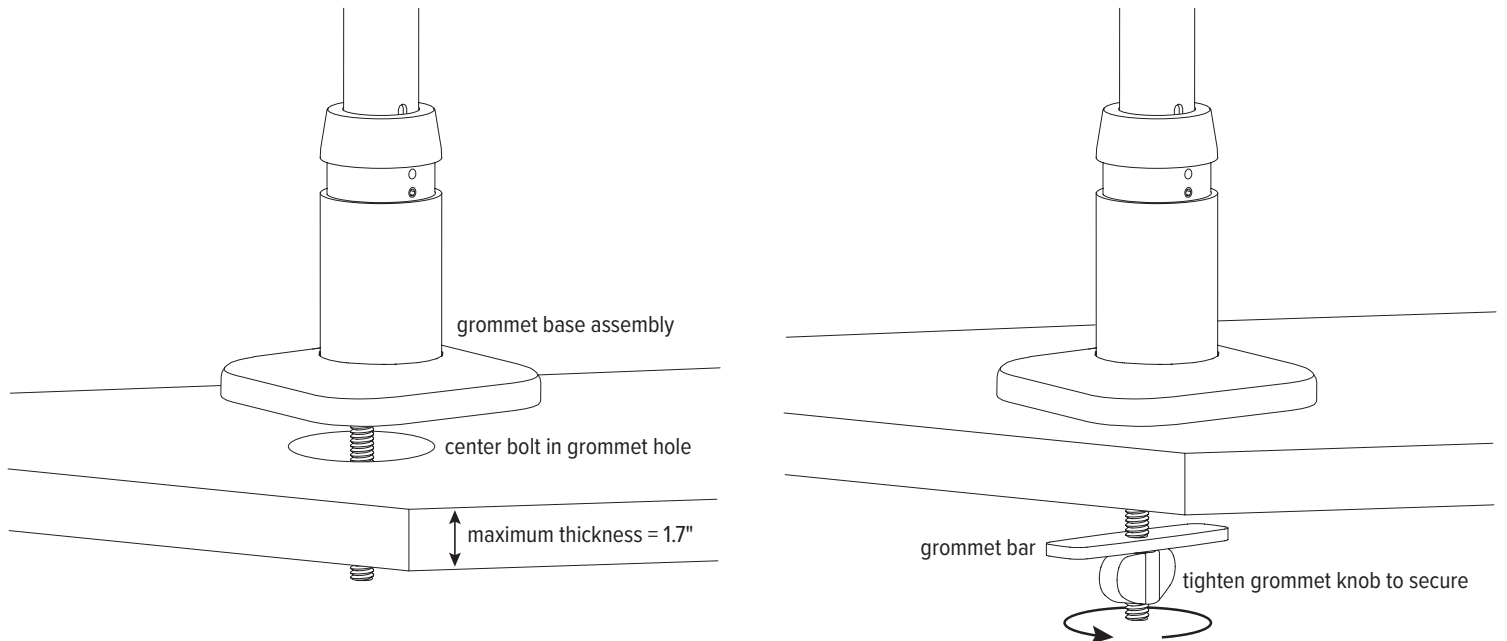



Step #2: if slider mount – assemble slider mount(s)

Important: When assembling the slider mounts, the groove on the slider bars must be at the bottom.

- Slide the VESA mount assembly onto the slider bar. Center the assembly on the slider bar.
- Install the M4x9 set screw into the bottom of the VESA mount assembly. Use the 2mm Allen key to tighten the set screw to hold the assembly in place. Be sure the screw tip fits into the groove on the slider bar.
 - After the monitor has been installed, the VESA mount can be moved anywhere along the slider bar by loosening the locking screw no more than one full turn (so that it stays inside the groove). Be sure to re-tighten the screw to secure the monitor in the desired position.

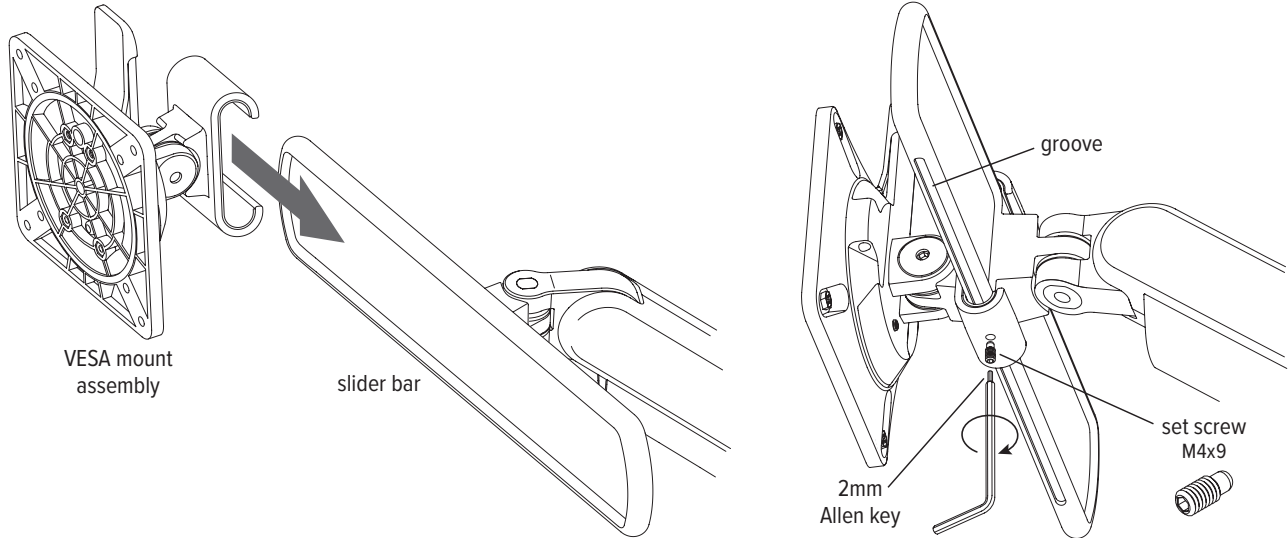

Step #3: install connection sleeve

The connection sleeve fits onto the mounting post and holds up to two monitor arm assemblies.

- Remove the locking ring from the connection sleeve.
 - Rotate the locking ring counterclockwise to unlock it and then lift it off.
 - Set aside the locking ring until it is needed in Step #5.
 - Slide the connection sleeve onto the post, usually with the screw toward the rear.
 - With the sleeve at the desired height, tighten the screw using the 4mm Allen key.
 - If necessary, the height of the connection sleeve may be adjusted after the monitors have been installed.
- Caution:** Be sure to have an assistant support the weight of the monitors and monitor arms before loosening the the screw on the connection sleeve.

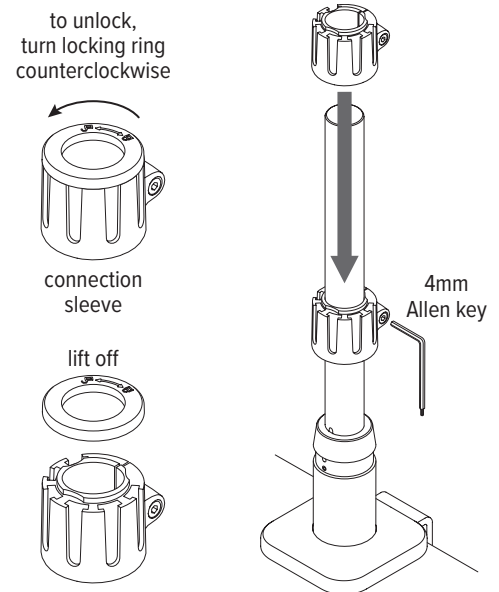

What is the “correct” connection sleeve height?

There is no exact answer to this question. Connection sleeve height depends on a number of factors: monitor arm configuration, height of the monitor(s), and eye level of the user.

The illustration shows the correct *relative* position for the different monitor arm configurations. Motion arms raise the monitors, so they are positioned lower on the mounting post than fixed arms. With two-arm assemblies, the inner fixed arm raises the second arm a couple inches, so fixed+motion and fixed+fixed arms are positioned lower than their respective single arm assemblies.

This illustration applies to a single row of monitors. For two-rows of monitors, see pages 6 to 8 and page 13.

*The position of the connection sleeve for a stem arm varies. To align its monitor with the outer monitors in a three-monitor row, the sleeve should be about 5" above the sleeve for a fixed+motion assembly and 3" above the sleeve for a fixed+fixed assembly. The sleeve for the stem arm is always the top connection sleeve.

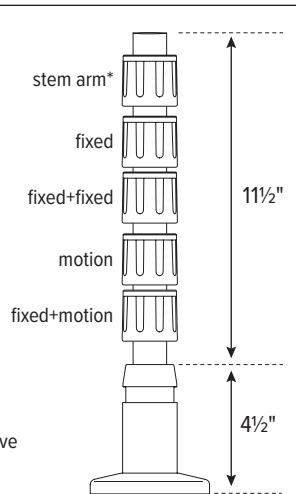

Step #4: attach up to two monitor arm assemblies

- Attach the monitor arm assembly(ies) by fitting the tabs on the end of the arm stem(s) into slots on the connection sleeve, as shown in the illustration at right.
- The tabs may fit into any two adjacent slots on the connection sleeve.
 - Typically, with one monitor arm assembly, the arm stem is installed into the center two slots so that it points forward.
 - With two monitor arm assemblies, the arm stems are usually installed on opposite sides of the connection sleeve, at a 180° angle, with two empty slots between them.
 - Two arm stems may also be installed at a 135° angle (one empty slot between arm stems) or a 90° angle (no empty slots between arm stems).

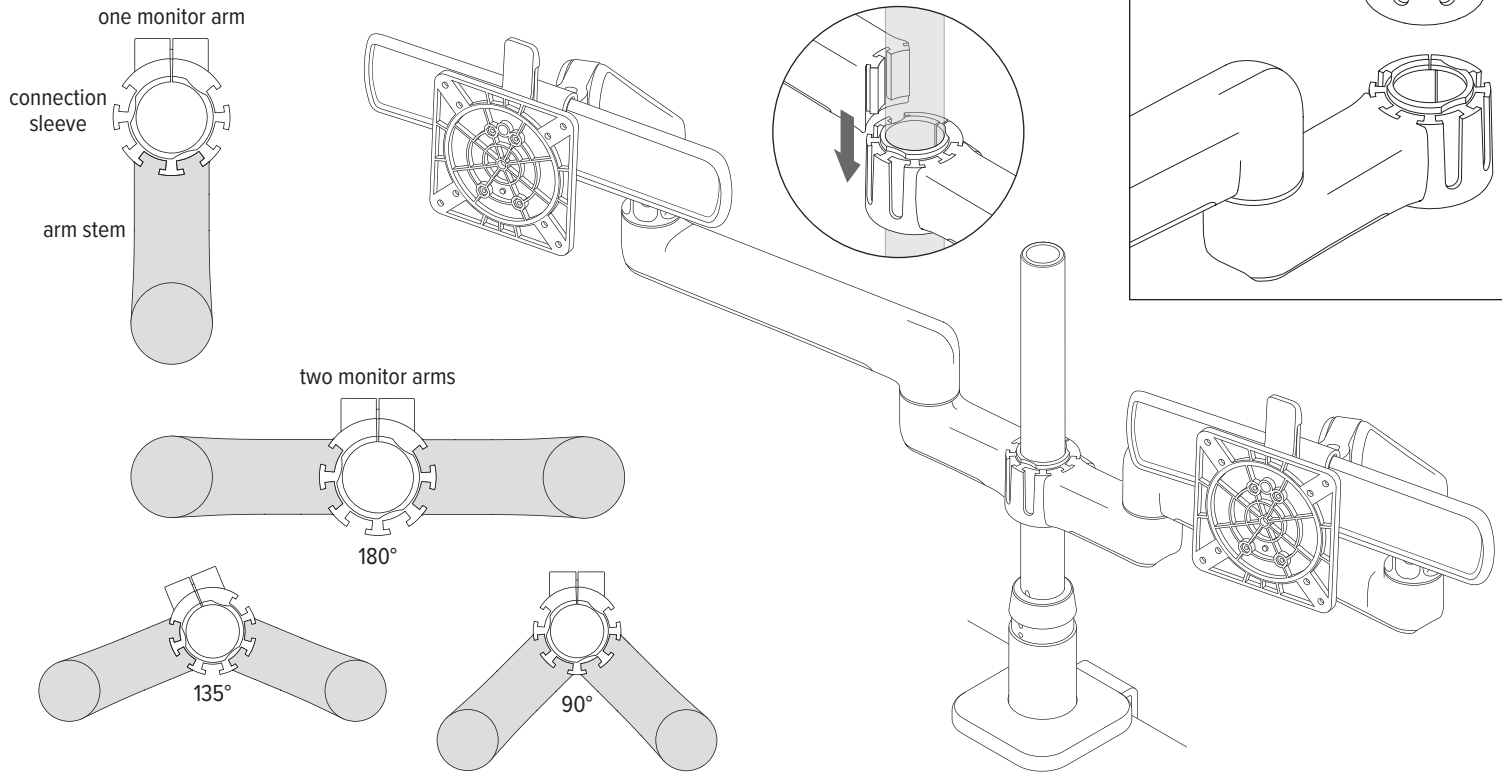
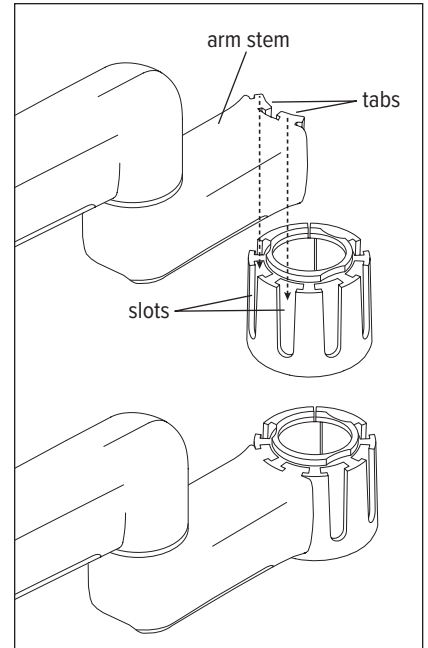

Step #5: secure up to two monitor arm assemblies

- Carefully cut the decorative covers to remove them from the set. Slide the covers into the unused slots on the connection sleeve.
- Lock the monitor arm assemblies to the connection sleeve with the locking ring. Rotate the locking ring clockwise to secure it.

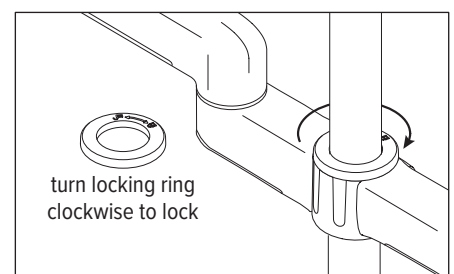
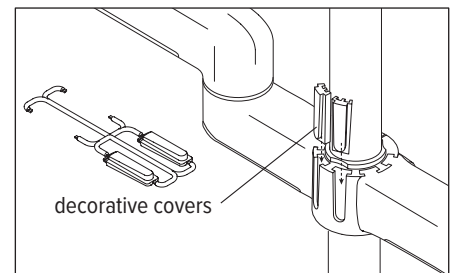



Step #6: *if three monitors* — attach center monitor arm

Below is an example of three monitor arms, which will form a row of three aligned monitors. One additional connection sleeve is used to accommodate the third monitor arm.

- Remove the locking ring from the second connection sleeve.
- Install the sleeve about 3" above the first sleeve if the other two arms are fixed+fixed; or about 5" above the first sleeve if the other two arms are fixed+motion. (See boxed text on page 10.) The objective is to align the VESA mounts — and thereby the monitors — at the same height.
- Secure the connection sleeve by tightening its screw with the 4mm Allen key.
- Install the stem arm assembly onto the connection sleeve by sliding its tabs into the center two slots on the sleeve.
- Slide the decorative covers into the four unused slots on the connection sleeve.
- Lock the monitor arm to the connection sleeve with the locking ring. Rotate the locking ring clockwise to secure it.

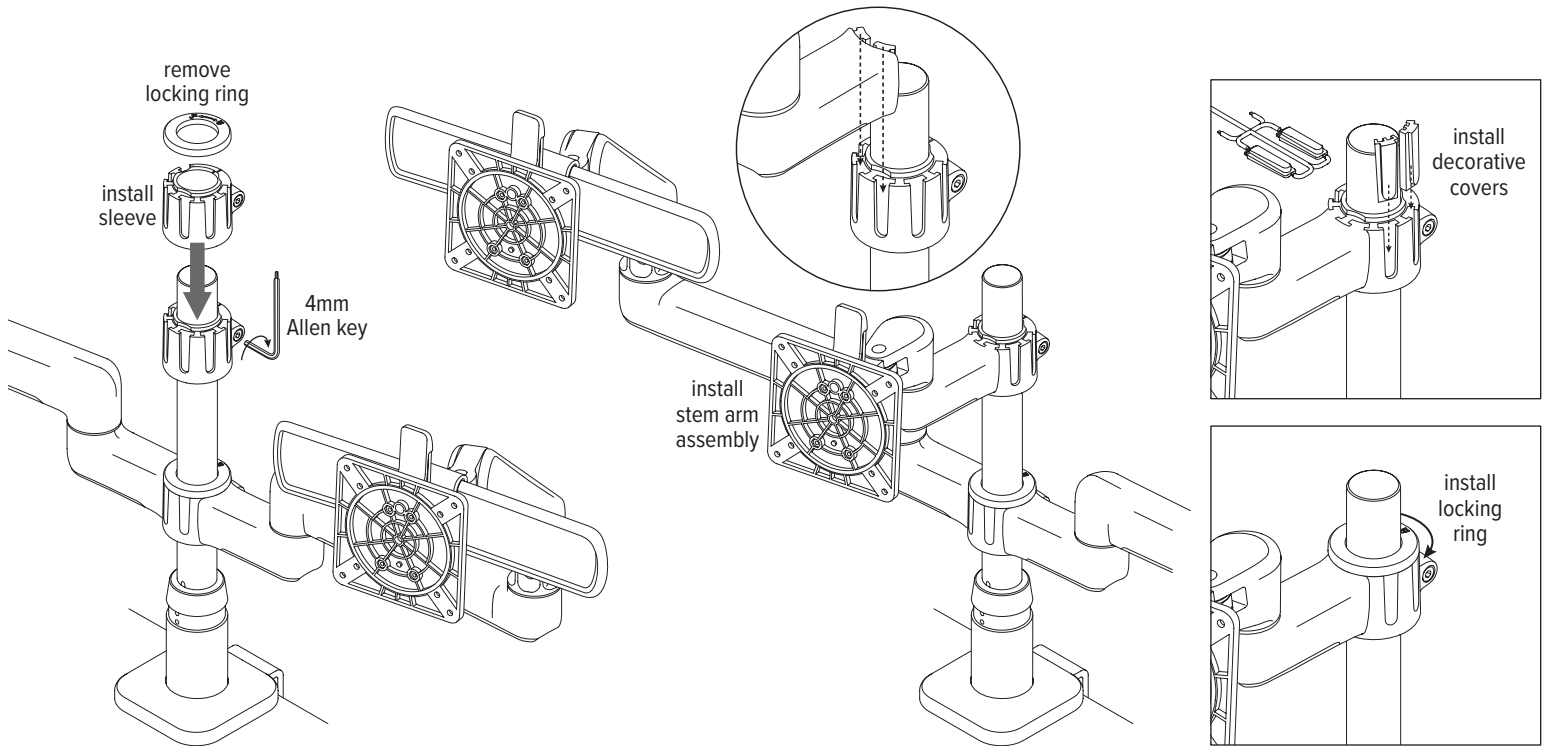



Step #7: if two rows of monitors — repeat steps #3 to #6

If two rows of monitors are needed (four or six monitors), the tall KataEX post is required. This larger post is 12" taller than the standard 16" post, which allows for the additional row of monitors. The relative positions of the connection sleeve(s) for both rows are the same, with the top row sleeve(s) about 12" above the bottom row sleeve(s). To be more precise, for the two rows of monitors to abut, the sleeves should be the height of the monitors apart, plus approximately 1/4" for tolerance.

- First, complete the installation of the bottom row of monitor arm assemblies.
- Then repeat steps #3 to #6.
 - Install the first connection sleeve for the top row of monitors at the appropriate distance above the corresponding bottom row sleeve.
 - Install the monitor arm assemblies for that sleeve.
 - Secure the monitor arm assemblies with the locking ring.
 - If there are three monitors in the top row, install the connection sleeve for the stem arm assembly. Then install and secure the stem arm assembly.

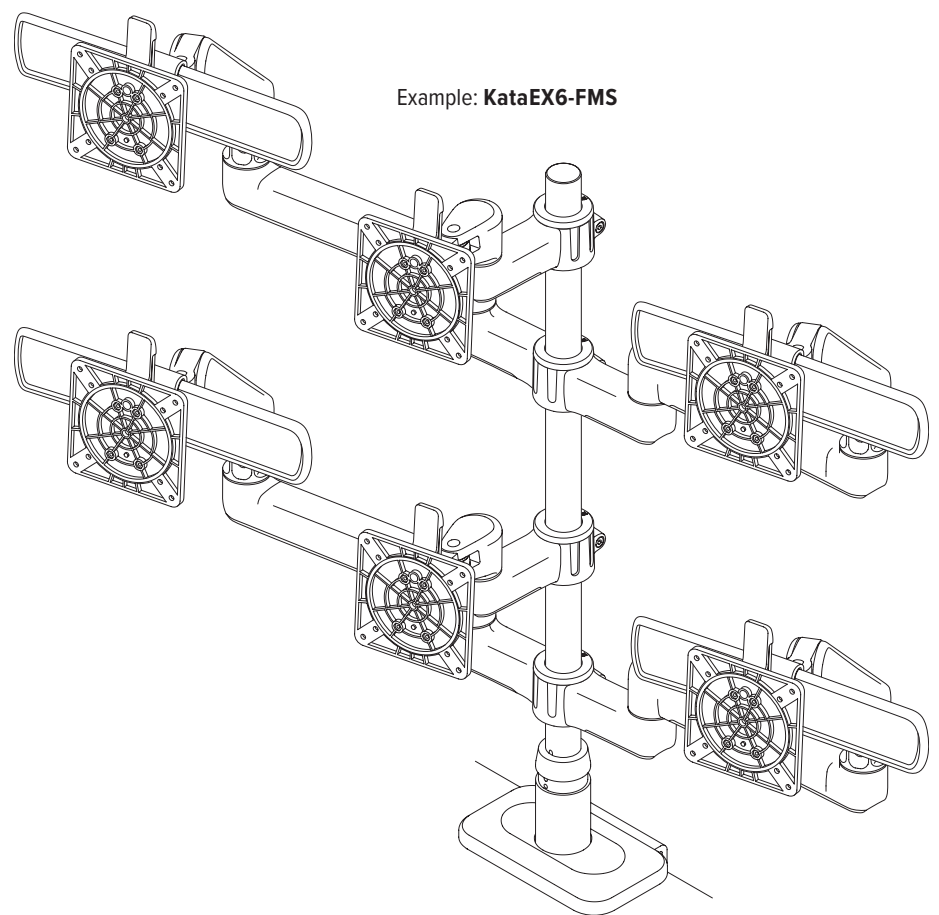
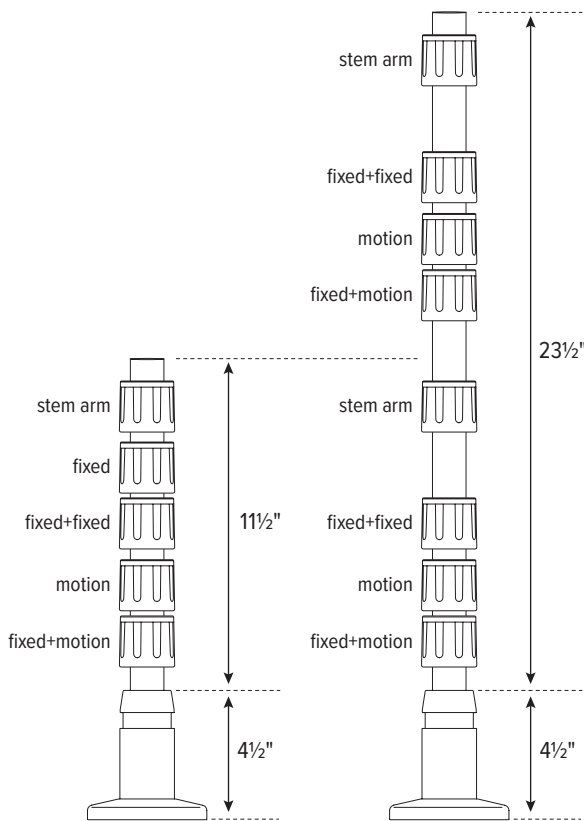

Possible connection sleeve positions with one row of monitors (*left*) and two rows of monitors (*right*). Note that only three of the four monitor arm types are used in two-row configurations: motion, fixed+fixed, and fixed+motion.

Step #8: attach VESA plate(s) to monitor(s)

- Remove each VESA plate from its VESA mount by **(1)** pushing forward the tab at the top and **(2)** lifting upward.
 - **TIP:** Practice re-installing the VESA plate before attaching it to the monitor. This will make step #9 easier.
- Place the monitor face down on a flat surface. Align the VESA plate holes with the holes on the back of the monitor. Attach the VESA plate using the four VESA plate screws provided.
 - There are two sets of four holes on the VESA plates. One set has holes 3.9" (100mm) apart, the other set has holes 3" (75mm) apart. Use the set that matches the holes on the rear of the monitor.

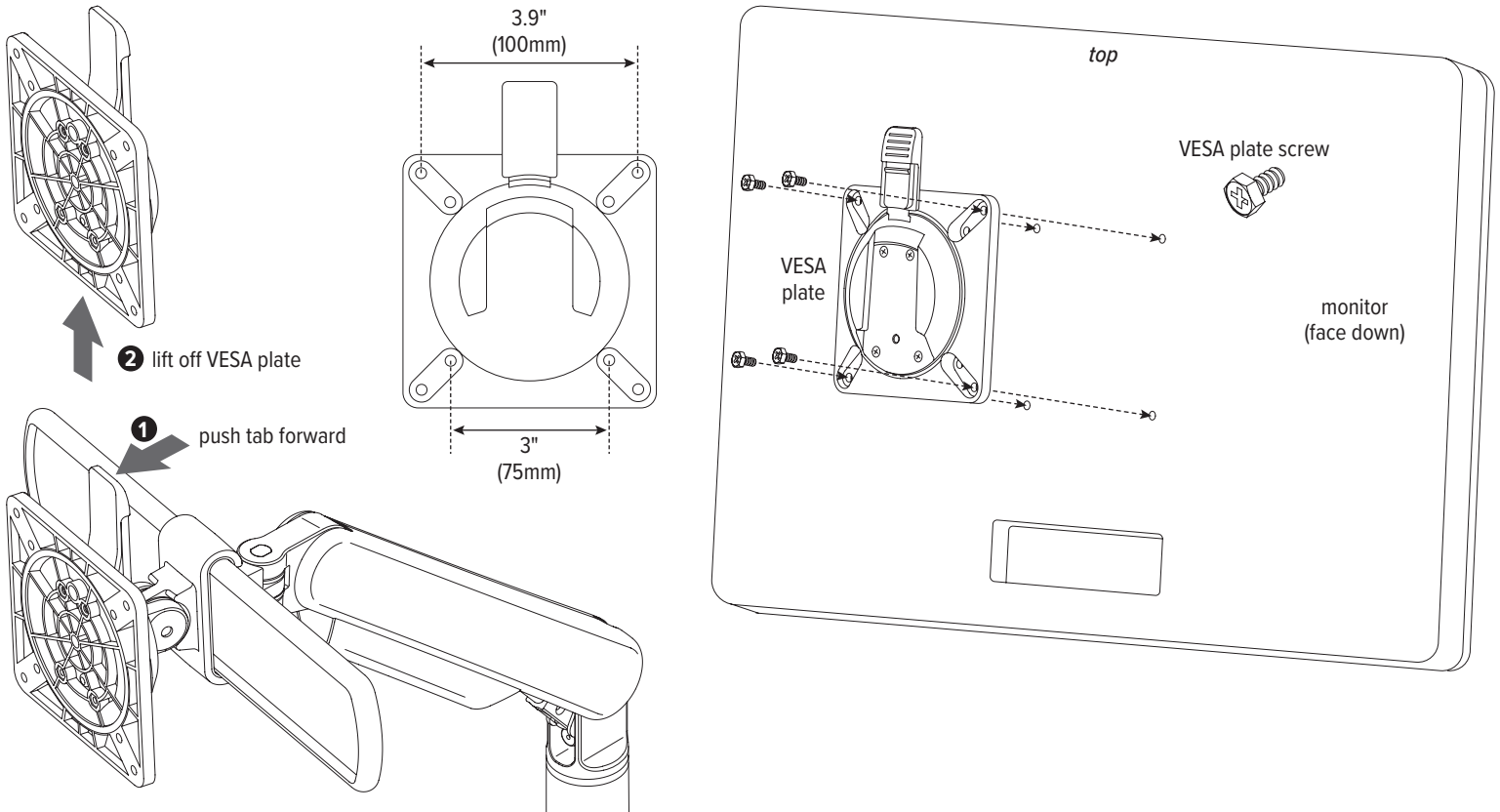

Step #9: attach monitor(s) to VESA mount(s)

- Slide the VESA plate (with monitor attached) back onto the VESA mount.
 - Make sure the VESA plate clicks securely in place.
- **Optional:** Secure the VESA plate to the VESA mount using one of the M4x15 set screws, as shown below. With slider mounts, tilt the monitor upward for access to install the set screw.

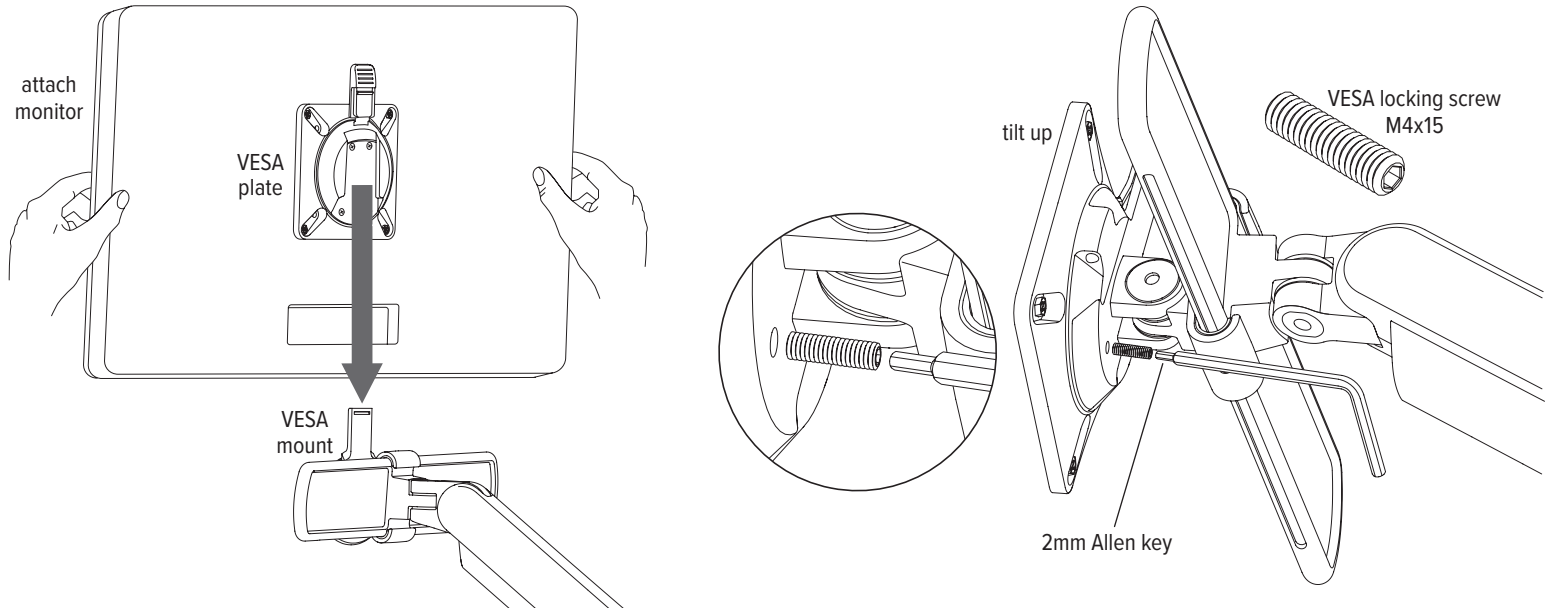

Step #10: remove cable management covers

- To remove the cover from motion arms, slide the cable cover upward.
- To remove the cover from the fixed arms, arm stems and Standard Stem arms, slide the cable cover out.

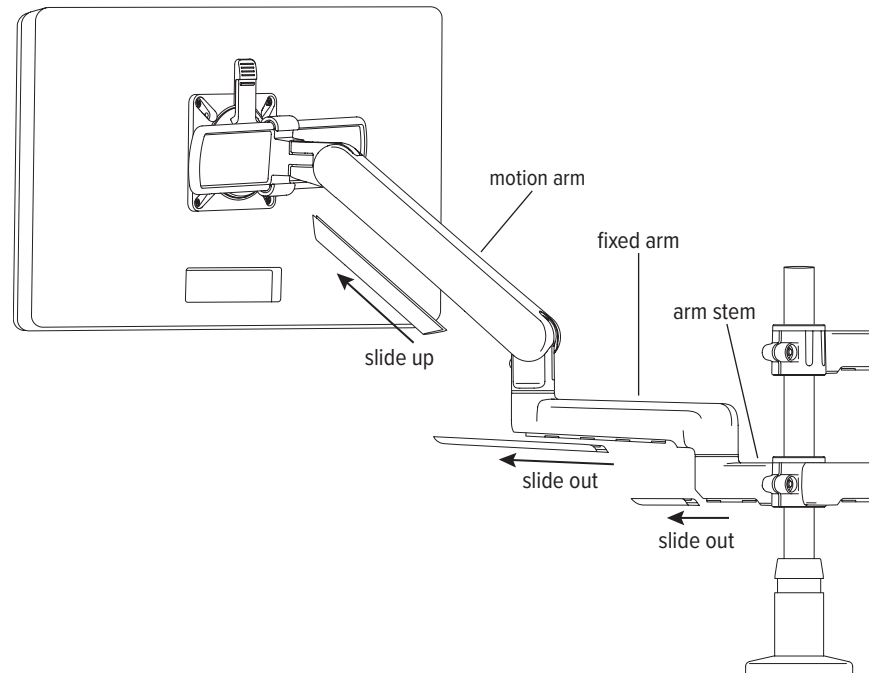

Step #11: optional – install lockout set screws

Default rotation of the fixed arms and motion arms is 360°. Lockout set screws limit rotation to 180°, either to the left or to the right.

- To lockout rotation, install an M4x15 set screw in the underside of the arm stem or fixed arm. Use the 4mm Allen key. Tighten the screw, then back it off one turn.
 - Installing a set screw in the front hole allows 180° rotation to the right only, as shown at right. A set screw in the rear hole allows 180° rotation to the left only.
 - In the example below, to prevent the inner fixed arms from rotating to the rear (a left rotation with the left arm and a right rotation with the right arm), install a set screw in the front hole on the left arm stem and in the rear hole on the right arm stem. The outer fixed arms are allowed their full 360° of rotation, so no set screw is installed at the end of the inner fixed arms.
- The fixed arm or motion arm must be in its allowed range of rotation when installing the lockout set screw.
- The lockout function is not recommended to apply to a head adapter, either at the end of a fixed arm or at the end of a stem arm.

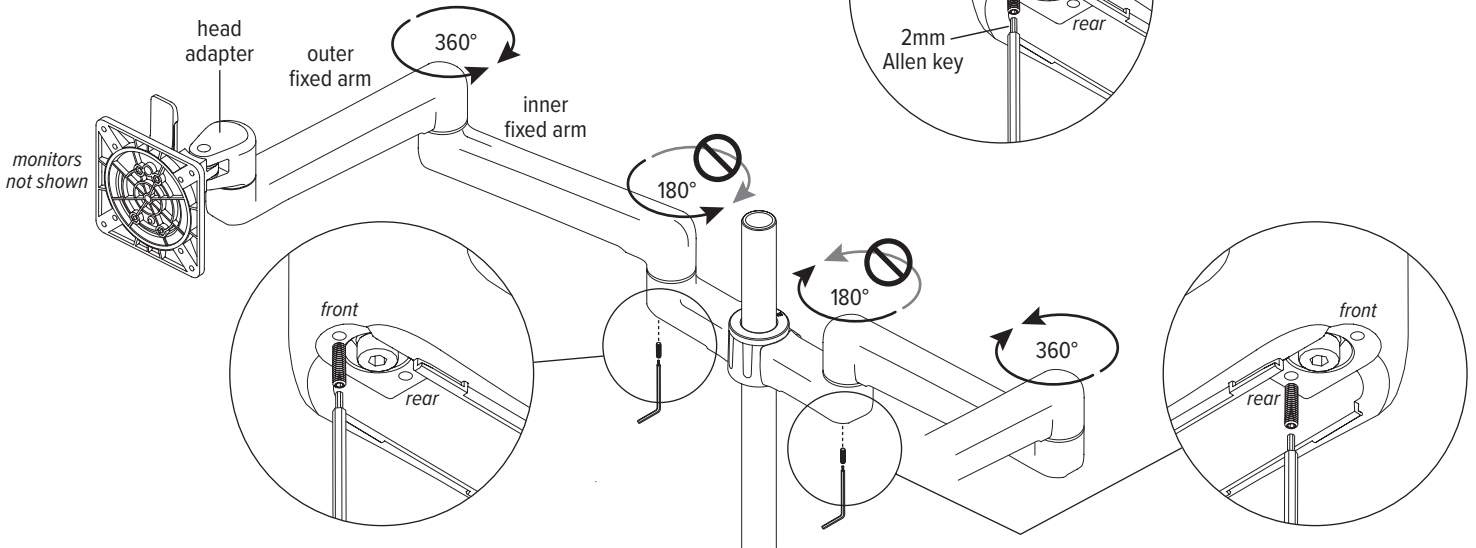
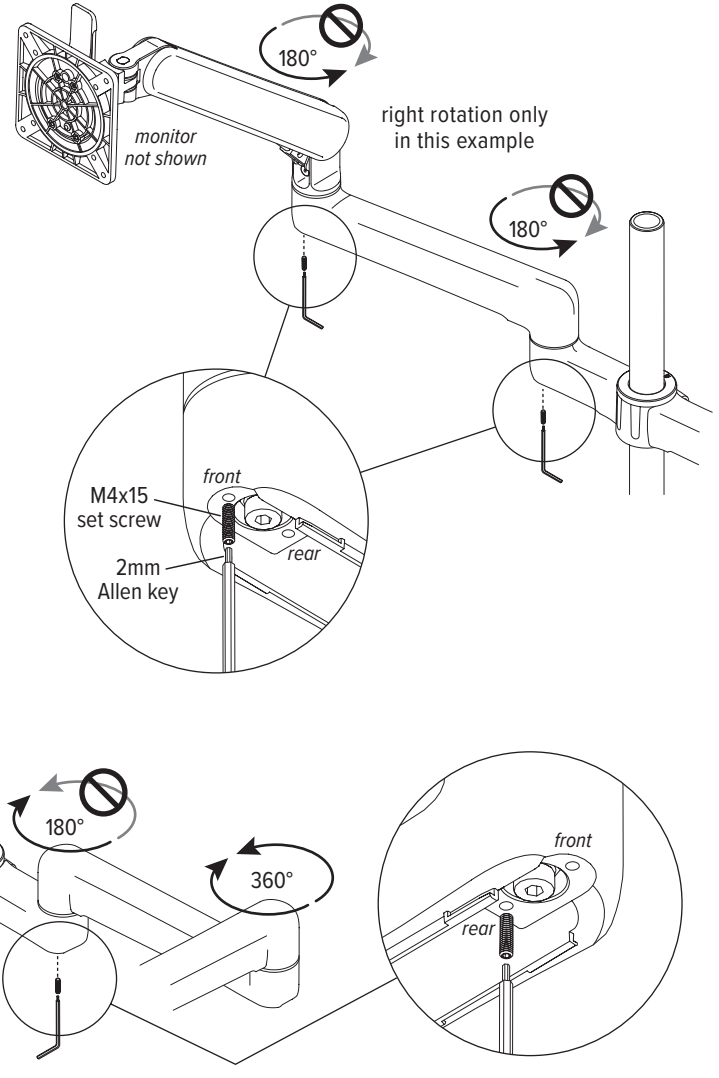

IMPORTANT: Remember to never position a monitor behind the mounting base location. Take this into account when installing lockout screws.

When should you lockout left or right rotation?

It is never *required* to lockout rotation in one direction or the other. As long as the workstation has a consistent user who understands how over-rotation might damage the monitor or its surroundings, monitor arm movement does not need to be restricted by set screws. Healthy precautions never hurt, however — if the restrictions are well-planned and the set screws are installed correctly.

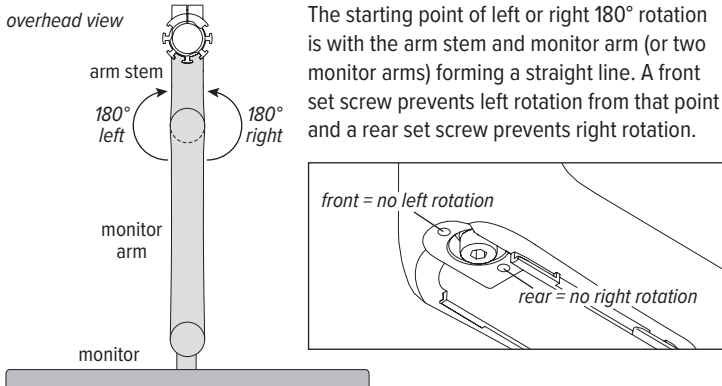

It's helpful to arrange monitors in their approximate final locations and decide if and where rotation restrictions are useful. These diagrams show a few examples.

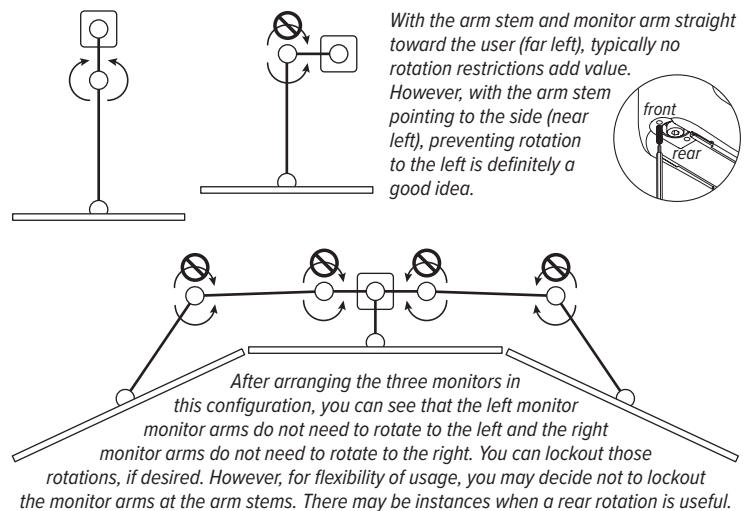



Step #12: organize cables and cords

The illustration below shows a fixed+motion three monitor arm configuration. All possible cable covers are shown: motion arm, fixed arm, and arm stem.

- Capture the cables and cords with the cable covers. Slide the cable covers as shown to attach them to the monitor arms and arm stems.
- Snap the cable clips onto the post and into the recessed groove above the base.
 - With two rows of monitors, snap a second cable clip onto the post under the top row.
- Route the monitor cables and power cords toward the rear by slipping the cords into the openings on the cable clips.

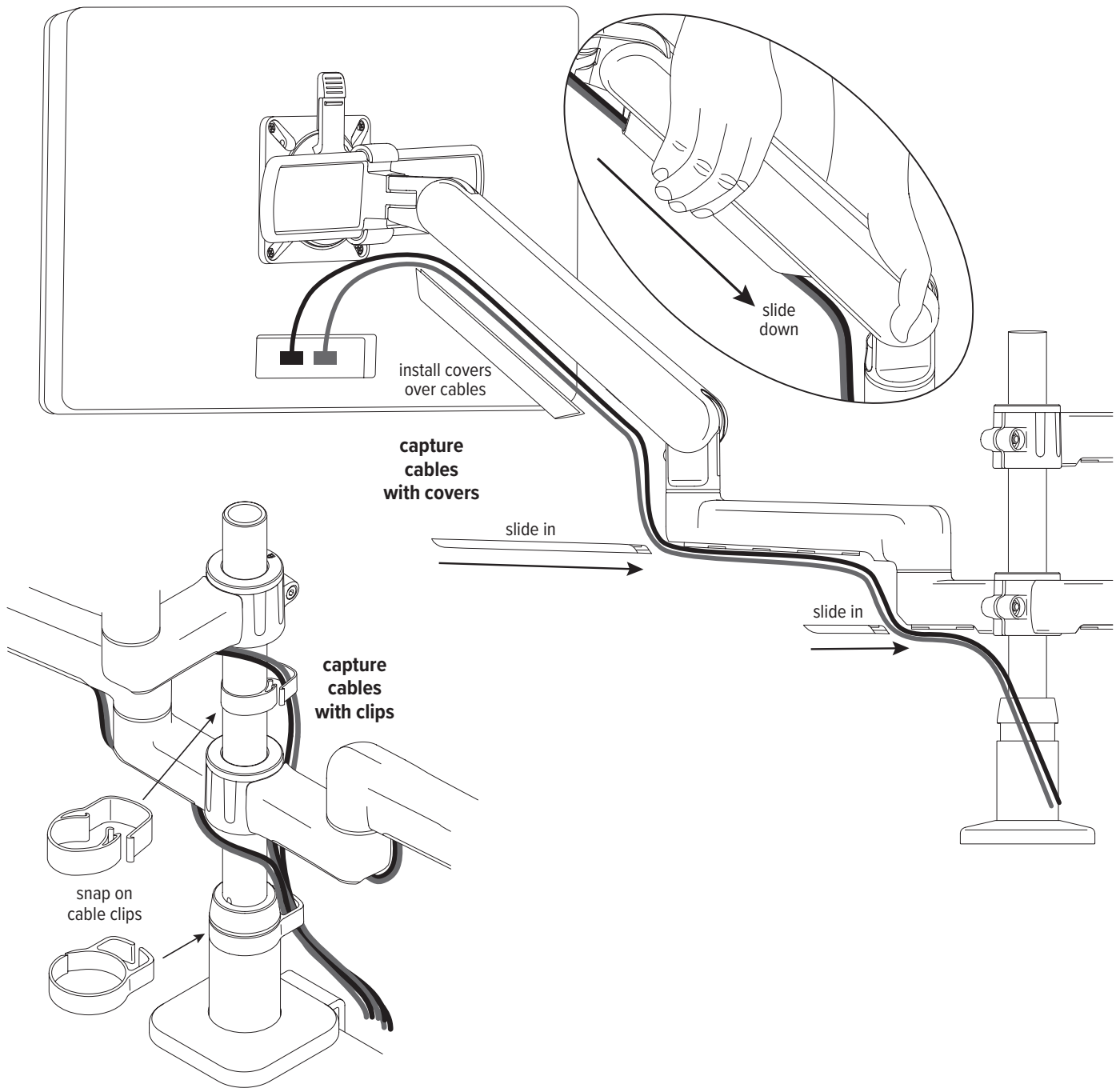

Step #13: make any necessary adjustments

Depending on the configuration, there are up to seven possible ways to adjust and change the position of the monitors to maximize the efficiency and comfort of the working environment. The illustration of a KataEX3-FMS configuration on the following page shows all seven ways. Five types of adjustments are shown in the illustration below of a KataEX2-FF configuration with VESA mounts attached to fixed arms.

1. Slider mount only: Monitor position on slider

- To move the monitor from side-to-side, use the 2mm end of the dual Allen key to loosen the set screw (M4x9) on the bottom of the VESA mount assembly, then slide the monitor along the slider bar. Do not loosen the set screw more than one full turn — the tip of the set screw must remain inside the groove on the slider bar so that the mount assembly cannot slide off the ends. Re-tighten the set screw when the monitor is positioned where desired.

2. Monitor tilt

- Use the 4mm end of the dual Allen key to loosen the screw on the side of the VESA mount to change monitor tilt angle. Tighten the screw to hold the angle.

3. Monitor swivel

- Use the 4mm end of the dual Allen key to adjust the underside screw behind the VESA mount or slider mount for the desired ease of monitor rotation.

4. Head adapter

- Use the 4mm end of the dual Allen key to adjust the underside screw at the end of the arm stem for the desired ease of head adapter rotation. In effect, this is the same as the monitor swivel adjustment. Head adapters are used to attach monitors to fixed arms and stem arms.

5. Motion arm weight

- Use the 4mm end of the dual Allen key to adjust the screw at the end of the motion arm for the appropriate monitor weight. When adjusted properly, the monitor weight is balanced, making it easy to raise or lower the monitor.

6. Motion arm swivel

- Use the 4mm end of the dual Allen key to adjust the screw in the underside of the arm stem or fixed arm for the desired ease of motion arm rotation.

7. Fixed arm swivel

- Use the 4mm end of the dual Allen key to adjust the underside screw at the end of the arm stem or inner fixed arm for the desired ease of fixed arm rotation.

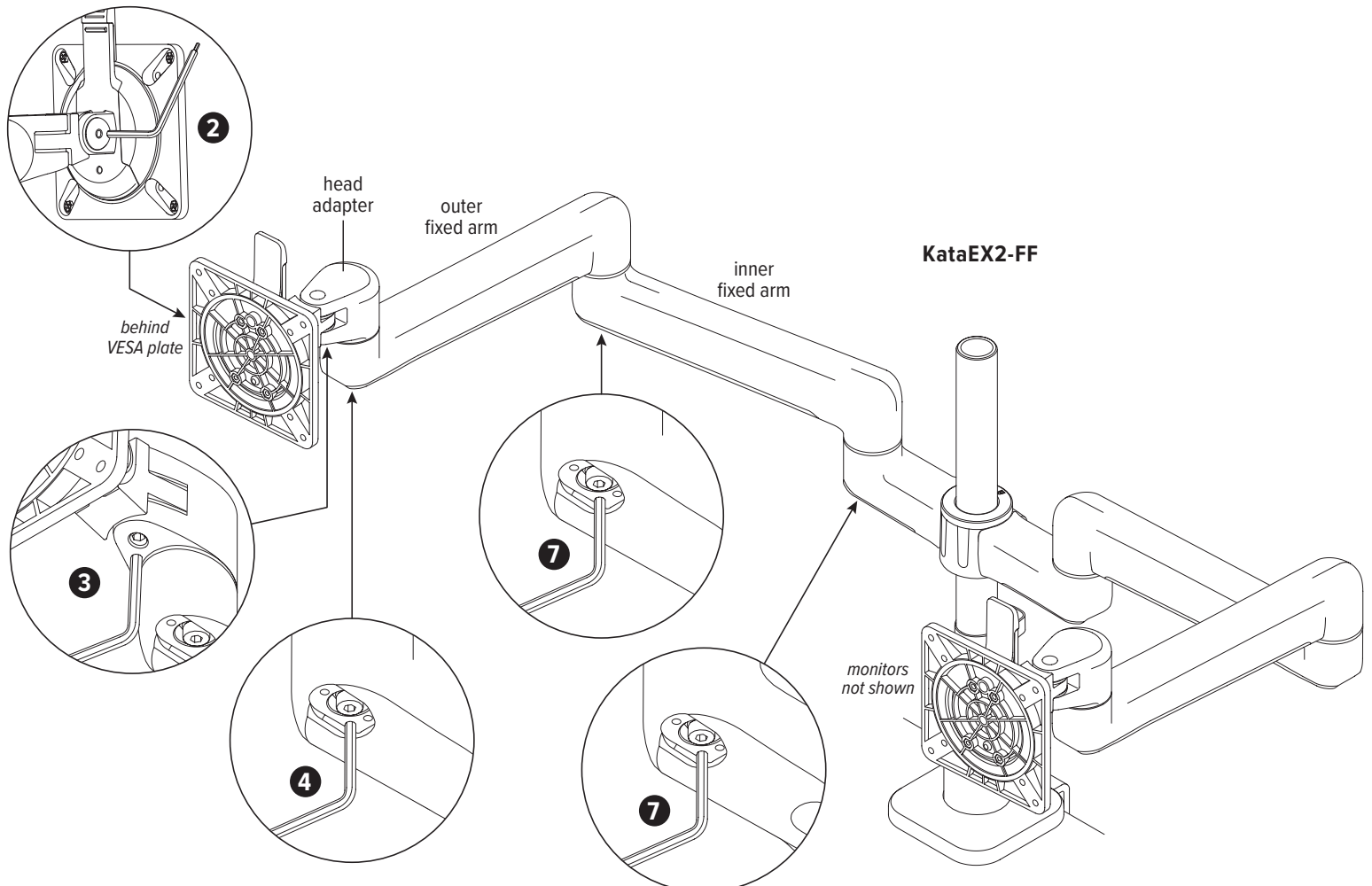



KataEX3-FMS

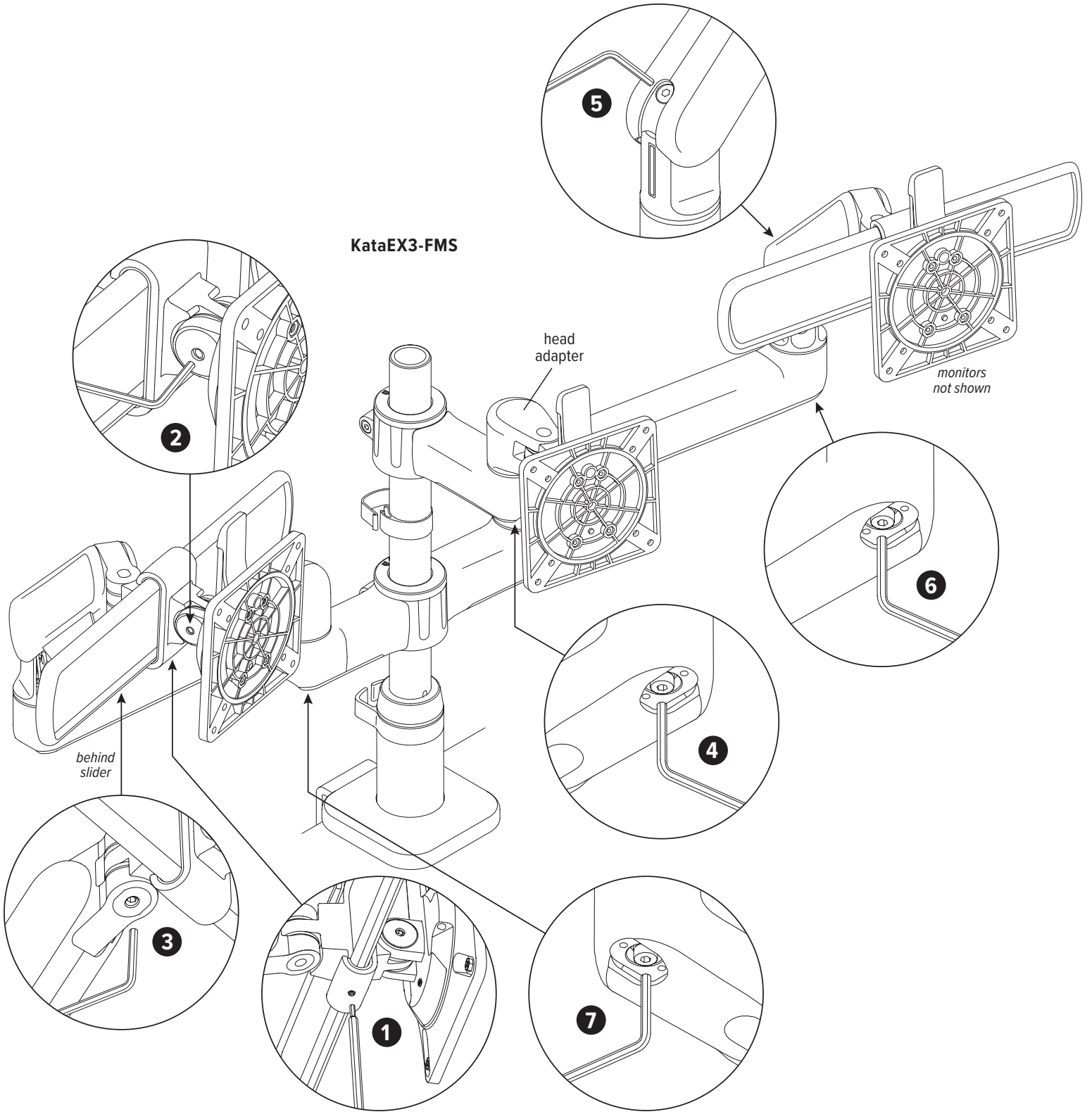



Kata™ EX

monitor arm series

Please contact Customer Service with any questions or comments at 800.833.3746 or visit our website at esiergo.com

LIMITED WARRANTY

ESI warrants this product to be free from defects in manufacturing for a period of 15 years from the date of original purchase. This warranty extends only to the original purchaser, and does not apply if the product has been damaged or fails to function properly as a result of misuse, abuse, modification, alteration, or improper cleaning or maintenance. This warranty does not apply to damage in shipment caused by carriers, damage caused during installation, normal wear and tear, or excessive use (meaning consistent use in excess of an eight hour shift). ANY IMPLIED WARRANTIES OF MERCHANTABILITY OR FITNESS FOR A PARTICULAR PURPOSE ARE LIMITED IN DURATION TO ONE YEAR FROM THE DATE OF ORIGINAL RETAIL PURCHASE. ESI's sole obligation under this warranty or any implied warranty, and the purchaser's sole remedy, is limited to the repair or replacement, at ESI's option, of the product or any defective part. Costs (such as installation, labor fees or express shipping) incurred due to replacement of products are not covered under warranty. IN NO EVENT SHALL FELLOWES, ITS AFFILIATES, SUBSIDIARIES, RELATED ENTITIES OR THEIR RESPECTIVE OFFICERS, DIRECTORS, OR EMPLOYEES, BE LIABLE FOR INCIDENTAL, CONSEQUENTIAL, PUNITIVE, EXEMPLARY, OR SPECIAL DAMAGES.

To make a warranty claim, contact ESI at 800-833-3746 or customerservice@esiergo.com. You must provide proof of purchase, such as the original purchase order number.

The duration, terms and conditions of this warranty are valid worldwide, except where different limitations, restrictions or conditions may be required by local law.