

## PREMIUM

2 LEG ELECTRIC TABLE BASE

Model 2E-C36- - - -  
 Model 2E-C48- - - -  
 Model 2E-C60- - - -  
 Model 2E-C72- - - -  
 Model 2E-C84- - - -

2E Rev A 7/17

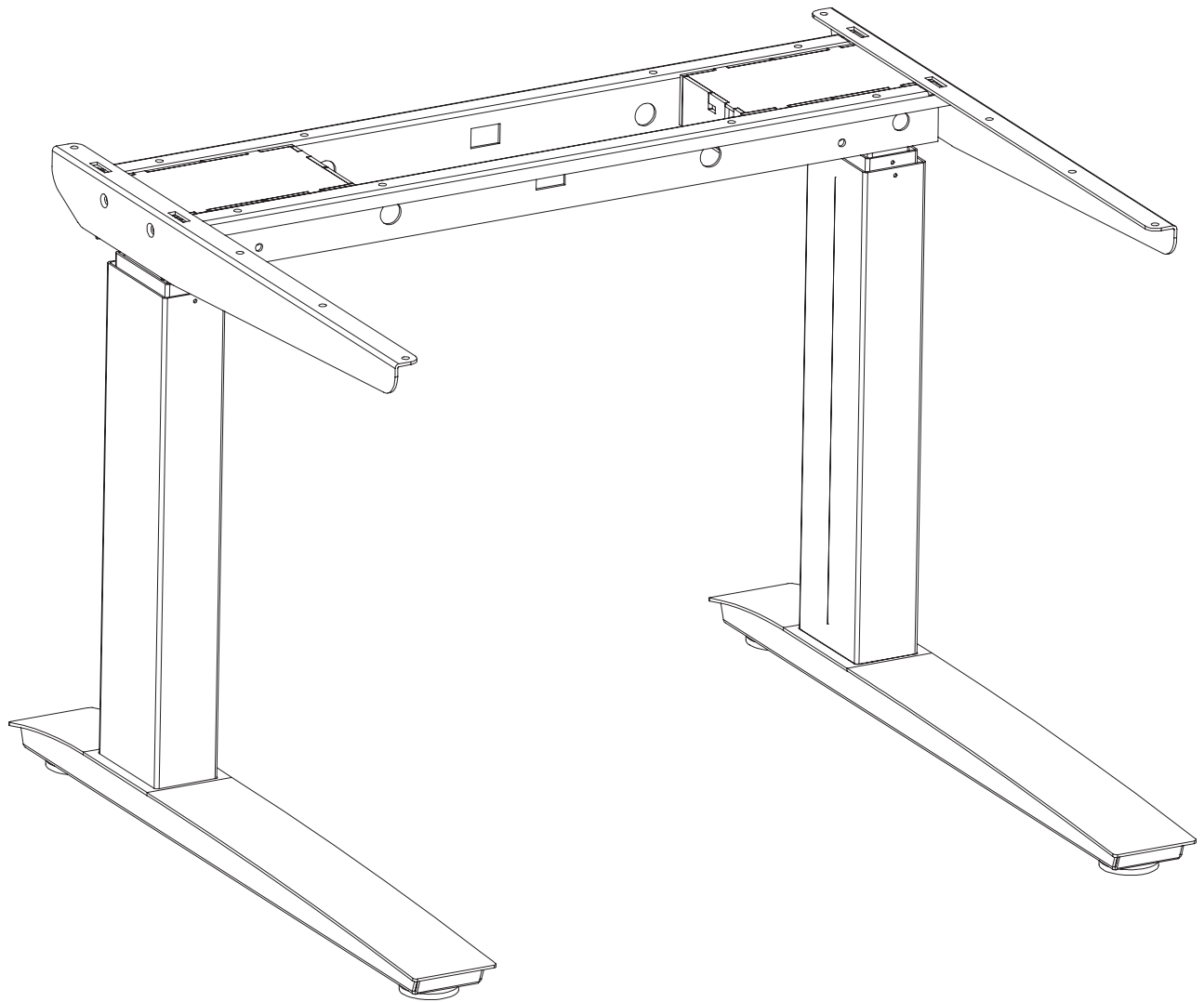

- - - - = 24-SLV, BLK or WHT  
 - - - - = 30-SLV, BLK or WHT



# ASSEMBLY AND OPERATION

**PLEASE REVIEW** these instructions before beginning the assembly procedures. Check that all the parts shown below were provided with your order. Contact your supplier if any materials are missing. Do not discard the packaging until content that the product operates to your satisfaction.

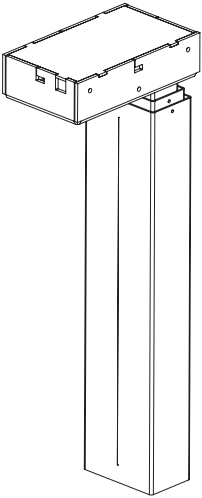
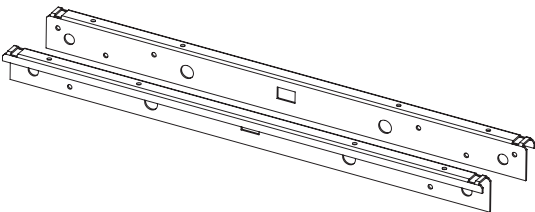
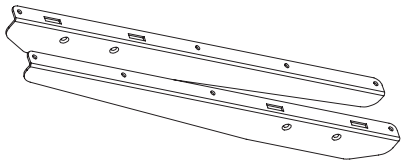
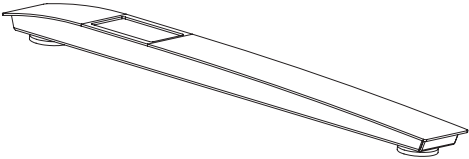
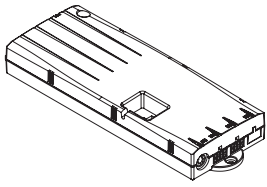
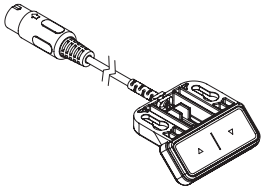
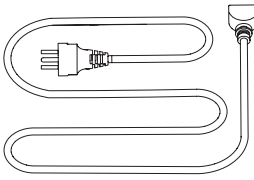
**PARTS PROVIDED**

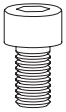
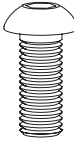
<p>Leg Columns (2)</p> 	<p>Cross Channels (2)</p> 	<p>Top Supports (2)</p> 	
	<p>Feet (2)</p> 	<p>Control Unit (1)</p> 	<p>Control Switch (1)</p> 
<p>Power Cable (1)</p> 	<p>Fasteners</p> <div style="display: flex; justify-content: space-around; align-items: center;"> <div style="text-align: center;">  <p>M6x12 Flat Head (4)</p> </div> <div style="text-align: center;">  <p>M6x12 Socket Head (18)</p> </div> <div style="text-align: center;">  <p>M10x20 Button Head (4)</p> </div> </div>		<p><b>CAUTION:</b> Hand-tighten screws only.</p>

**ADDITIONAL FASTENERS AND TOOLS REQUIRED**

- Power drill with assorted bits
- Wood screws to attach cross channels, top supports, control switch, and control unit to work surface
- 5mm Allen key
- 6mm Allen key
- #2 Phillips screwdriver
- Cable clips, cable clamps, and cable ties

**CAUTION:** Always check that screws used to attach components to the worksurface are not too long for the thickness of the surface.

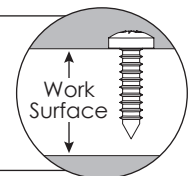

**STEP 1**

With the table top facing down on a soft, clean surface, arrange the leg columns and cross channels, as shown.

- Position the leg columns so the motors face inward.
- Position the "J" flange on the cross channels facing outward.

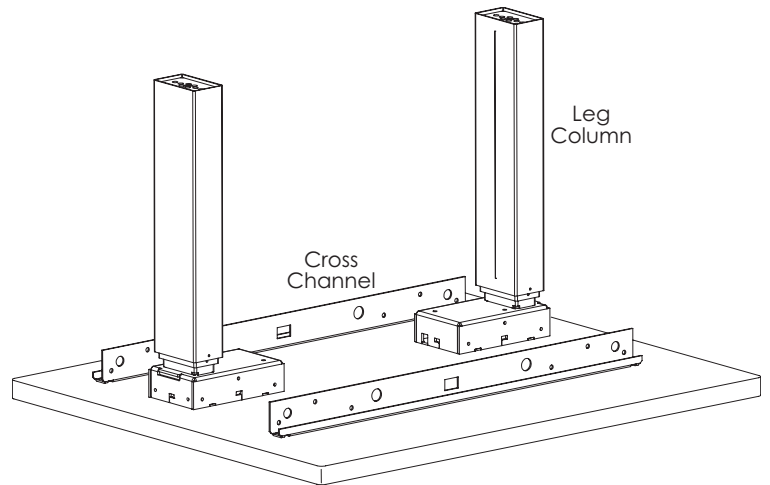
**STEP 2**

Attach the cross channels to the leg columns.

- Raise the leg columns with shims, about the thickness of one or two pieces of corrugated cardboard. This makes cross channel attachment easier.
- Use six M6x12 socket head screws per leg column, three per side.
- Tighten the screws with a 5mm Allen key.
- After attaching the cross channels, remove the shims from under the leg columns.

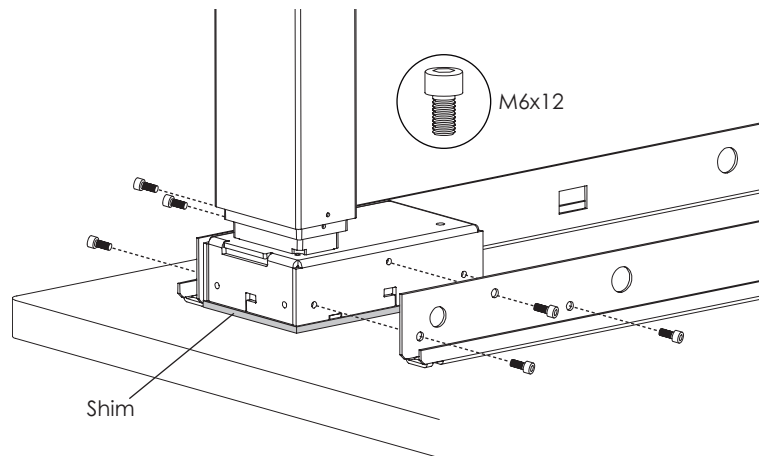
**STEP 3**

Attach the top supports to the leg columns.

- Position the flange on the top supports under the leg column and cross channels, with the short side of the top support toward the rear.
- Use two M6x12 flat head screws per leg column.
- Tighten the screws with a 5mm Allen key.

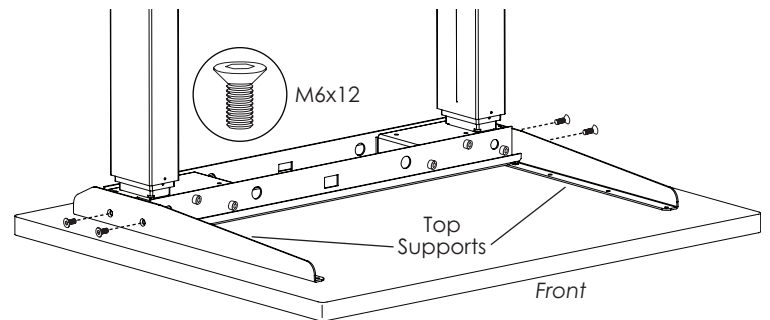
**STEP 4**

Attach the feet to the leg columns.

- Use two M10x20 button head screws per foot and tighten with a 6mm Allen key.
- The short side of the feet face the rear, matching the top supports.

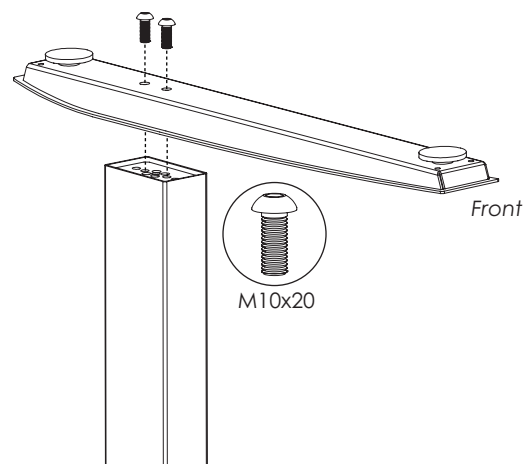

**STEP 5**

Adjust the position of the assembly before screwing it to the table.

- Center the assembly from side to side.
- Align the rear of the feet with the rear of the work surface.

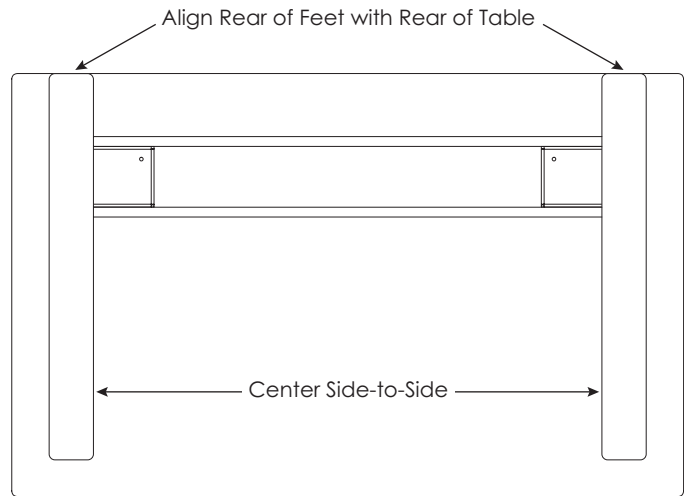

**STEP 6**

Once in their final position, attach the top supports and cross channels to the table.

- Use wood screws of an appropriate size. Be sure the screws are not too long for the work surface.
- Attach four screws per top support.
- The number of screws required for the cross channels varies from four to six per channel, depending on channel length.

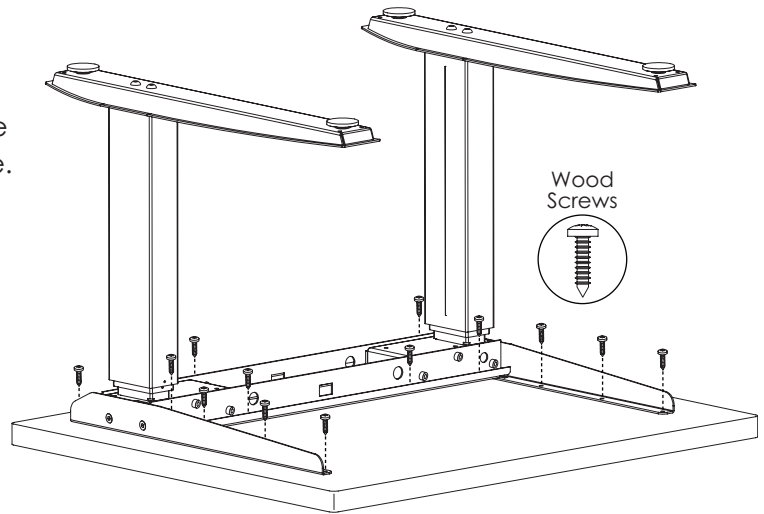

**STEP 7**

Attach the control switch using two wood screws of an appropriate size.

- Position the control switch on the left or right side of the table, according to user preference.
- Align the top of the control switch with the edge of the table so that the controls will be easily accessible to the user.

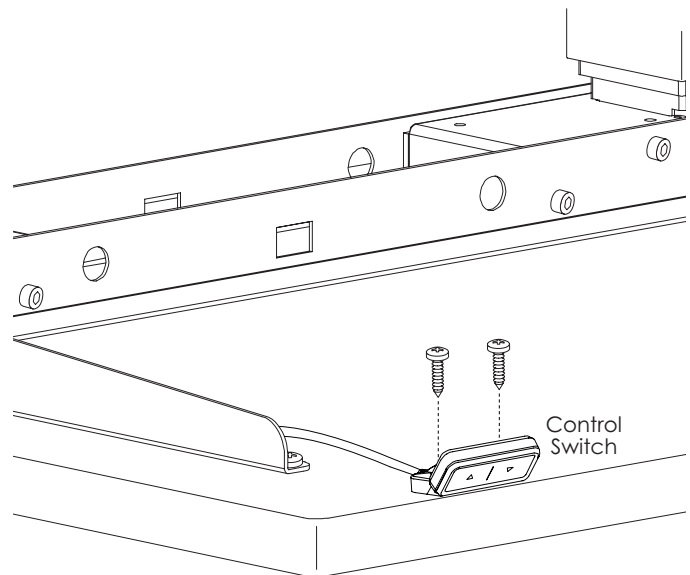

**STEP 8**

Attach the control unit using two wood screws of an appropriate size.

- Position the control unit between the cross channels, taking into account the location of the control switch and AC power outlet.
- Be sure the cables from the leg columns and the control switch can reach the control unit.

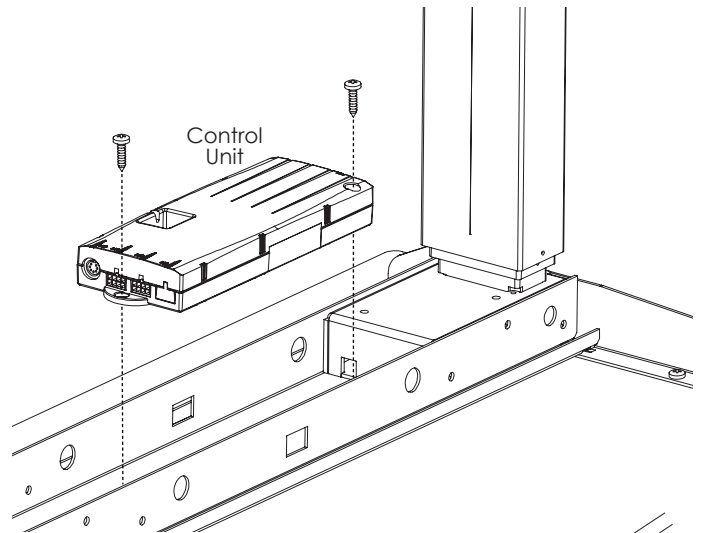
**STEP 9**

Make connections to the control unit.

- Connect the cable from the control switch.
- Connect the motor cables from the leg columns to the control unit.
- Connect the power cord to the control unit.
- Plug the power cord into an AC outlet.

**CAUTION:** Do not operate the table until after “zero setting” the system. See the following step.

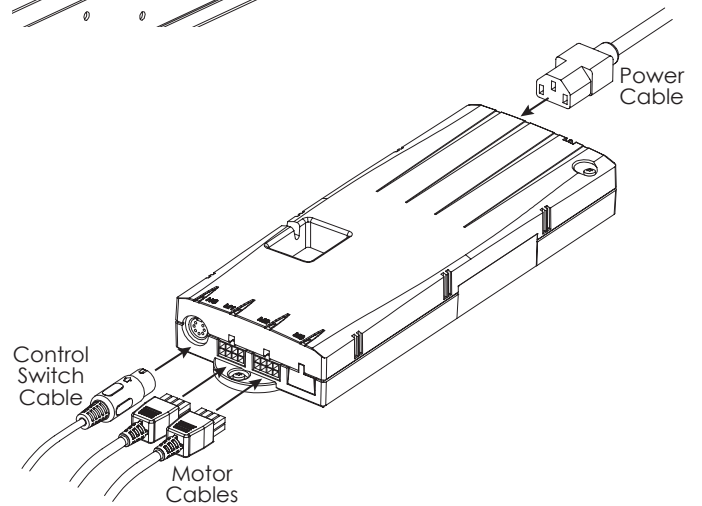
**STEP 10**

“Zero set” the system before testing operation.

**IMPORTANT:** If the optional Premium digital keypad was ordered, refer to the instructions that came with that keypad.

- Press DOWN ▼ to lower the legs to their lowest position. (Note that with the table upside-down, the DOWN arrow faces up).
- Continue to press DOWN ▼ until you hear a clicking sound and the columns move slightly upward.
- Press the UP ▲ and DOWN ▼ buttons to test operation. End your test with the legs lowered and unplug the power cord.
- If there are problems with operation, check that all cable and cord connections are secure. If problems continue, call ESI Customer Service.

**IMPORTANT:** If power is lost to the unit, the system must be “zero set” again.

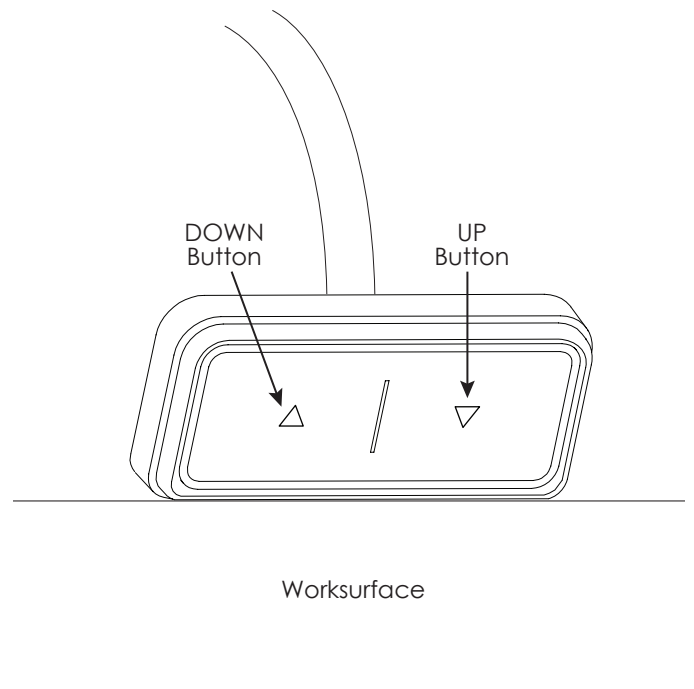

**STEP 11**

Use cable clamps and ties to secure the cables in position.

- Cables must not interfere with table operation.
- Cables must not interfere with the user.

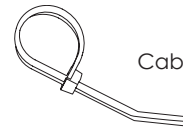
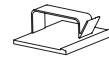

Cable Management

**STEP 12**

With the assistance of a helper, turn the table upright and place it in its final position.

**IMPORTANT:** There must be 1" (25mm) of clearance on all sides of the worksurface (and other moving parts) to ensure free, unobstructed movement.

- Adjust the leveling glides on the feet to level the worksurface, if necessary.
- Plug the power cord into an AC outlet.
- See the following page for operating procedures.

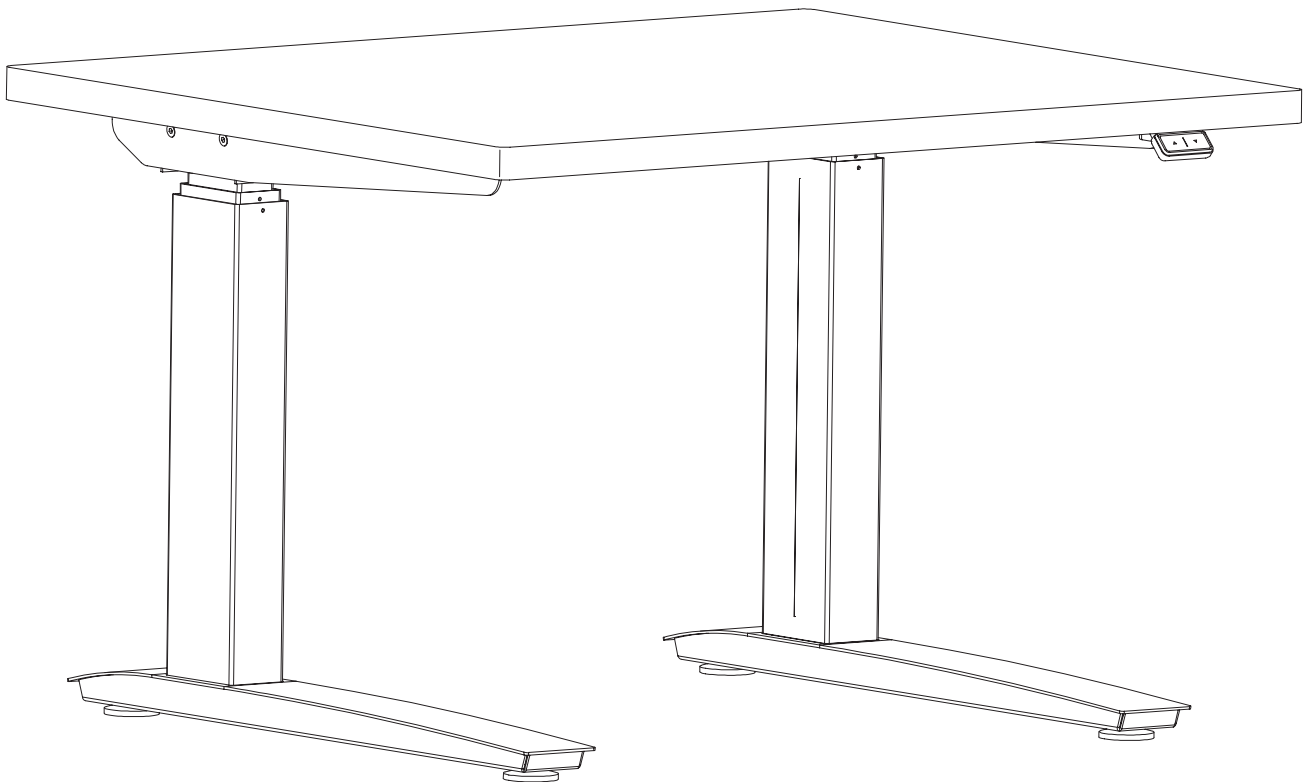

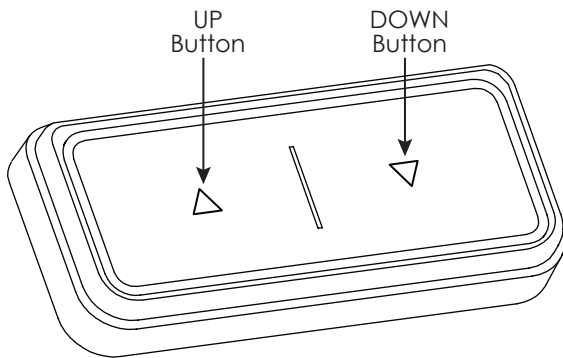

**CAUTION:** The “zero setting” procedure must be completed before operating the table. See Step 10 on page 5.

### **GENERAL OPERATION**

Move the table up or down by pressing UP ▲ or DOWN ▼ until the worksurface reaches the desired height.

The table will continue to move up or down until you release the button or until the maximum or minimum height is reached.

**IMPORTANT:** Always check for obstructions to table movement when moving the work surface to its minimum and maximum heights.

***Table movement stops when you release the UP ▲ or DOWN ▼ button.***



800.833.3746 | [esiergo.com](http://esiergo.com)