

ALL-FLEX™ ELECTRIC TABLE BASE

Model FLEX2-SLV-V3
Model FLEX2-BLK-V3
Model FLEX2-WHT-V3

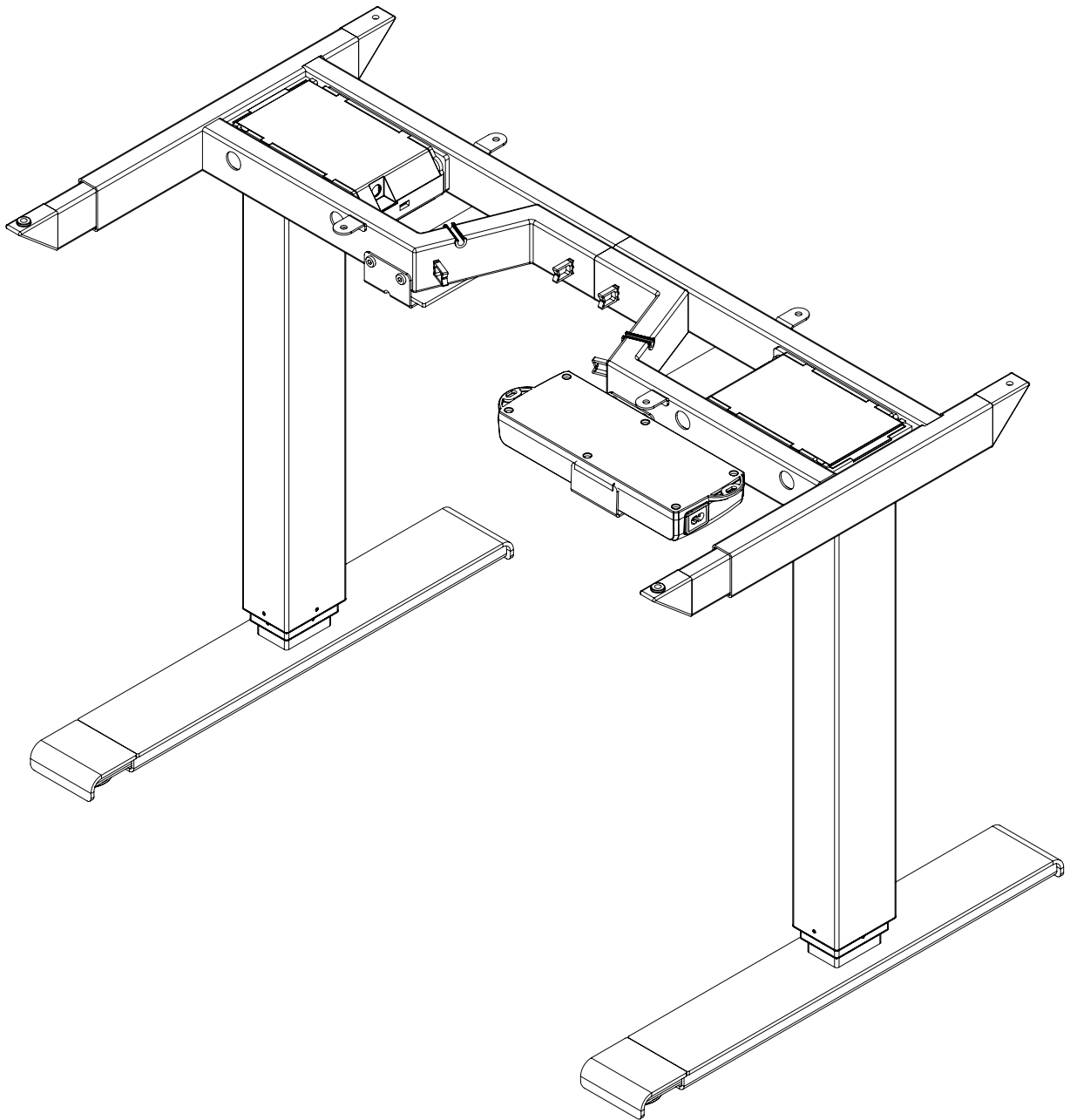

FLEX2 V3 Rev 01 7 /17



ASSEMBLY AND OPERATION

PLEASE REVIEW these instructions before beginning the assembly procedures. Check that all the parts shown below were provided with your order. Contact your supplier if any materials are missing. Do not discard the packaging until satisfied that the product operates to your satisfaction.

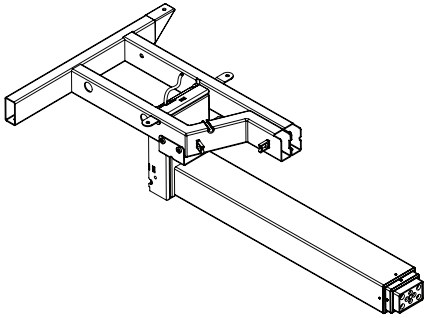
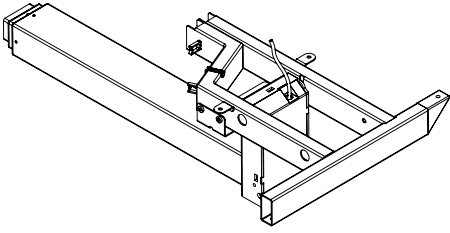
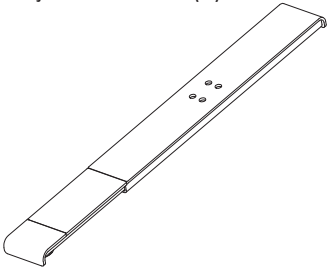
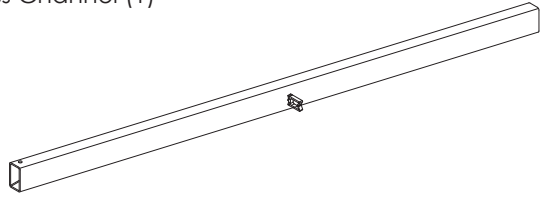
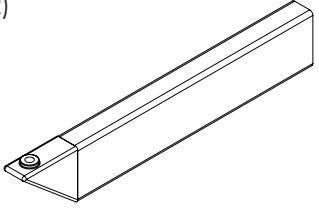
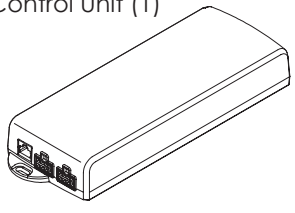
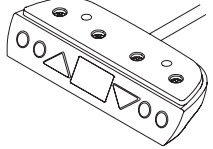
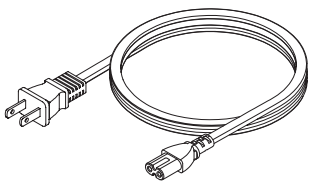
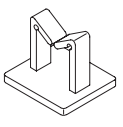
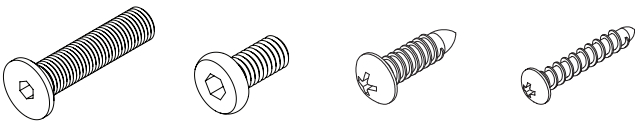
PARTS AND TOOLS PROVIDED

| | | | |
|--|---|---|---|
| <p>Leg hinged to Frame(L)(1)</p>  | <p>Leg hinged to Frame(R)(1)</p>  | <p>Adjustable Feet (2)</p>  | |
| <p>Cross Channel (1)</p>  | | <p>Top Supports (2)</p>  | |
| <p>Control Unit (1)</p>  | <p>Digital Keypad (1)</p>  | <p>Power Cable (1)</p>  | <p>Cable Clip (4)</p>  |
| <p>Fasteners</p>  <p>M10x45 (8) M6x15 (10) Ø5x18(10) Ø4x23 (2)</p> | | <p>Allen Keys (3)</p>  <p>3mm 4mm 5mm</p> | |

CAUTION: Hand-tighten screws only. Do **not** use power tools.

CAUTION: Always check that screws used to attach components to the work surface are not too long for the thickness of the surface.

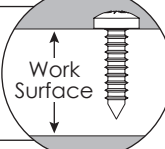

ADDITIONAL TOOLS REQUIRED

- Phillips screwdriver

STEP 1

- After turning the legs straight, use the 4mm Allen Key to fasten the M6x15 screws to the posts.
- Use the 4mm Allen Key to secure the screws within E-1 and F-1.

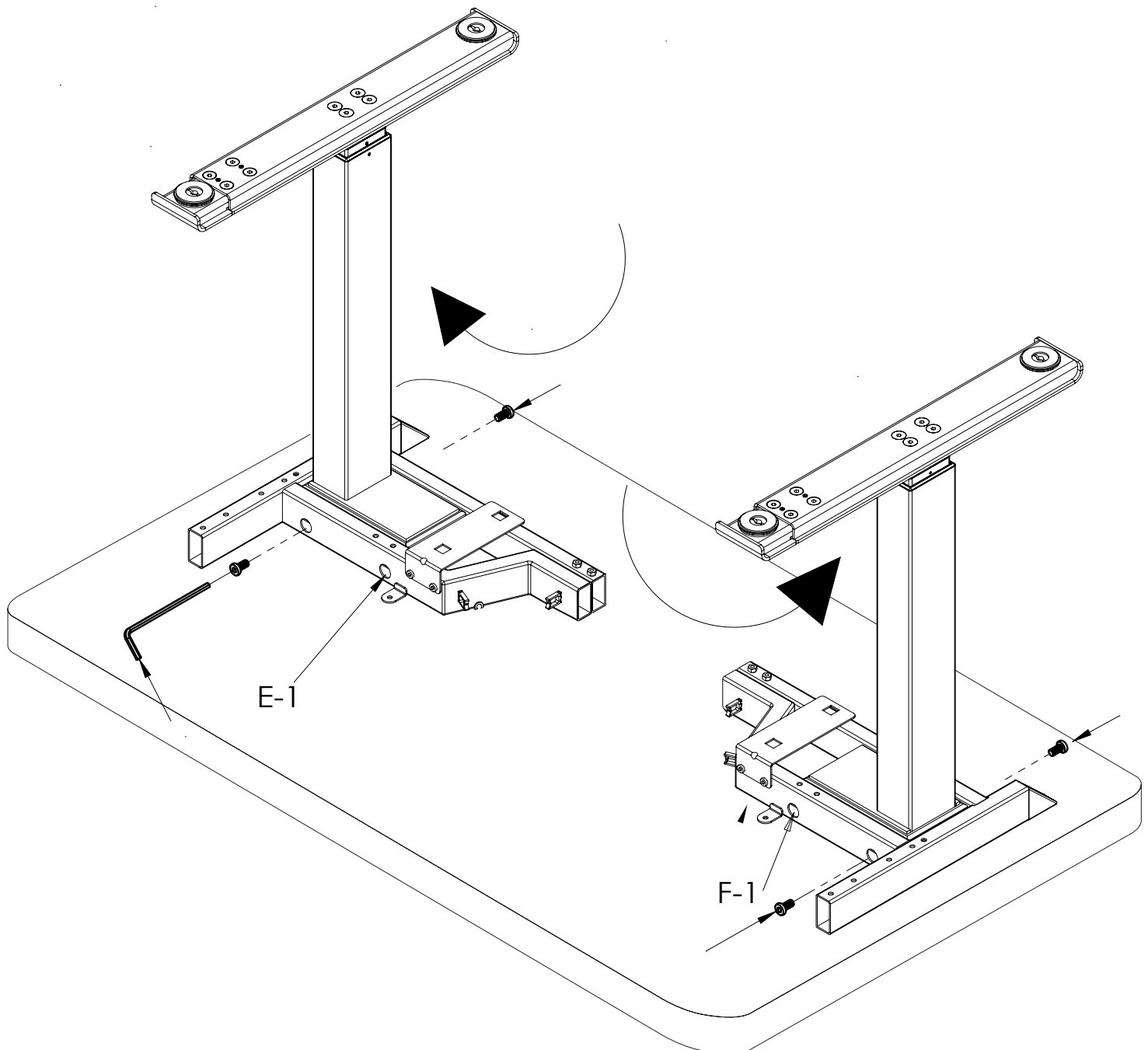

STEP 2

- Place the cross channel into the hinged posts and extend the frame to the full width of the table, allowing a minimum space of 1" (25mm) on each side.
- The frame can be expanded from 34" (86cm) wide to 64" (163cm) wide. The inner channel includes guides to assist in setting the desired width.
- Tighten the two set screws. The tab on the inner channel should be approximately centered.
- Center the frame on the worksurface and use the 4mm Allen key to fasten the M6x15 screws into place.

STEP 3

- Place the Top Supports into the frame and secure the remaining M6x15 screws.

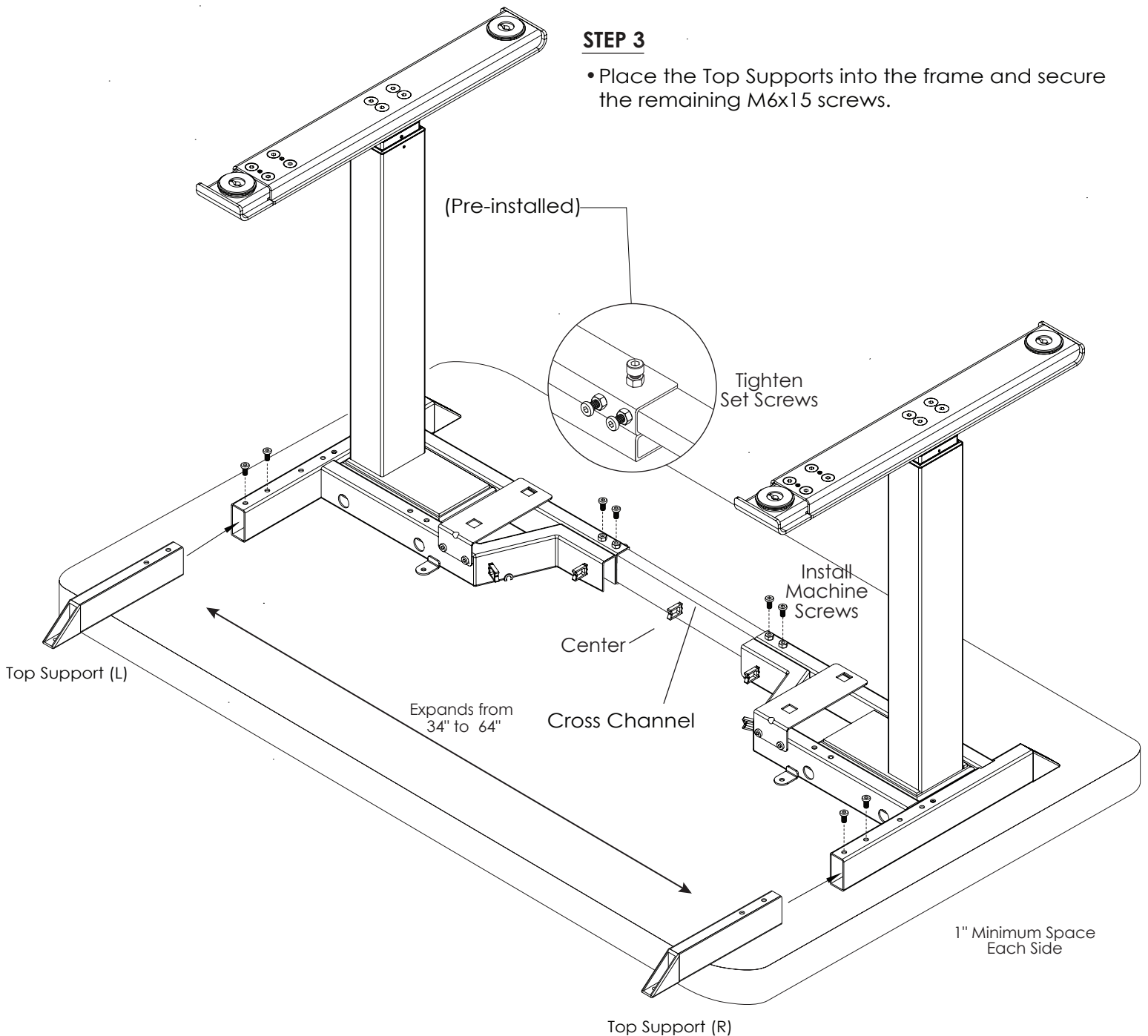

STEP 4

Adjust the position of the frame before screwing it to the work surface.

- Align the rear of the feet with the rear of the table.
- Expand the frame, if necessary, and center it from side to side. See Steps 9 and 10.
- Expand the top supports, if necessary. See Step 11.

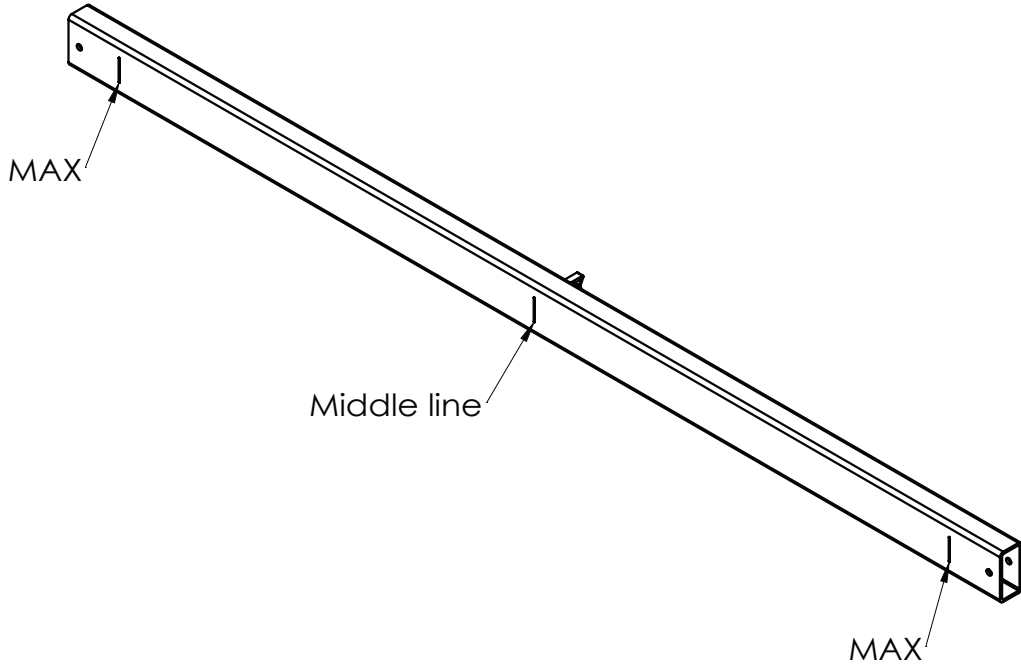
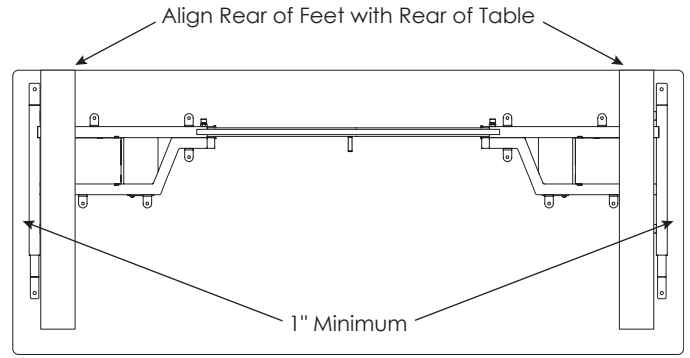

Attention : Please make sure not to pull out the bar over Max. mark.

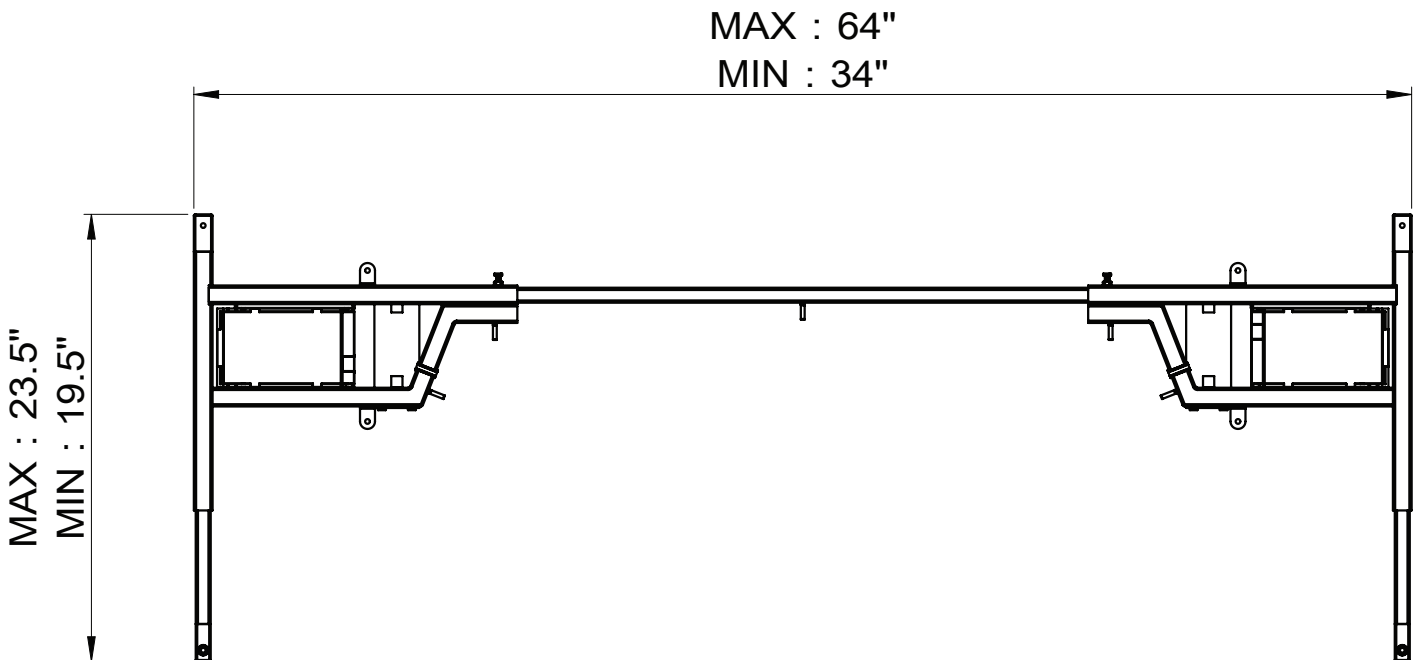

STEP 5

Change the length of the adjustable feet, if necessary.

- The length of the feet may be either 22" (55.9cm) or 28" (71.2cm). The feet are shipped in the 28" length. They should be changed to the shorter length if the work surface depth is less than 28".
- To change the length to 22", first remove the adjustment plate. Then use a 5mm Allen key to remove the four screws, as shown.
- Slide the feet to the 22" length and reinstall the four screws with the 5mm Allen key.
- Store unused adjustment plates in the brackets attached to the frame.

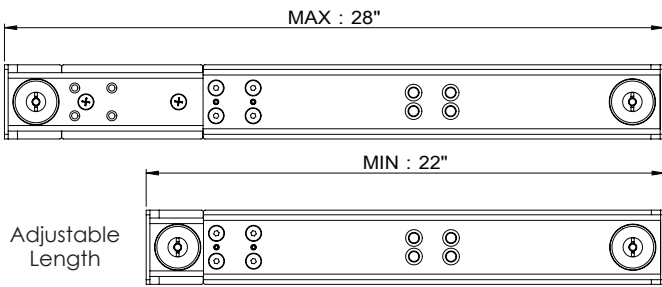

Unfasten the phillips screws in order to remove the cover plate.

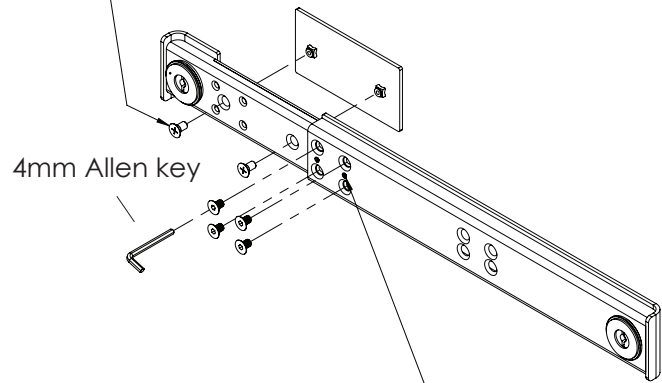
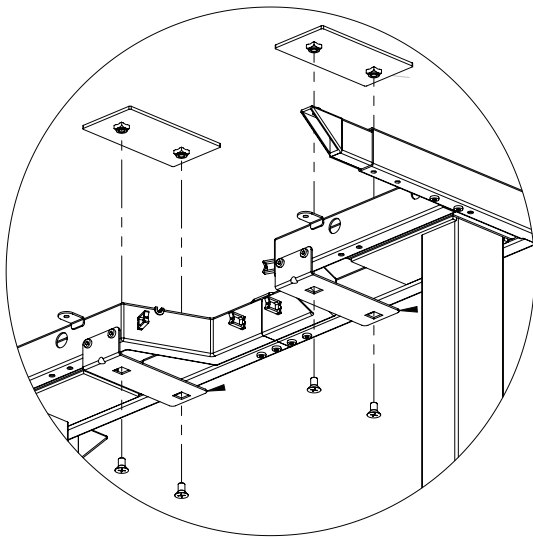

5mm Allen key — Before adjusting the feet, first unfasten these screw with the 3mm Allen Key.

STEP 6

Attach a foot to each of the legs.

- Use four M10x45 screws per foot.
- Tighten the screws with an 5mm Allen key.

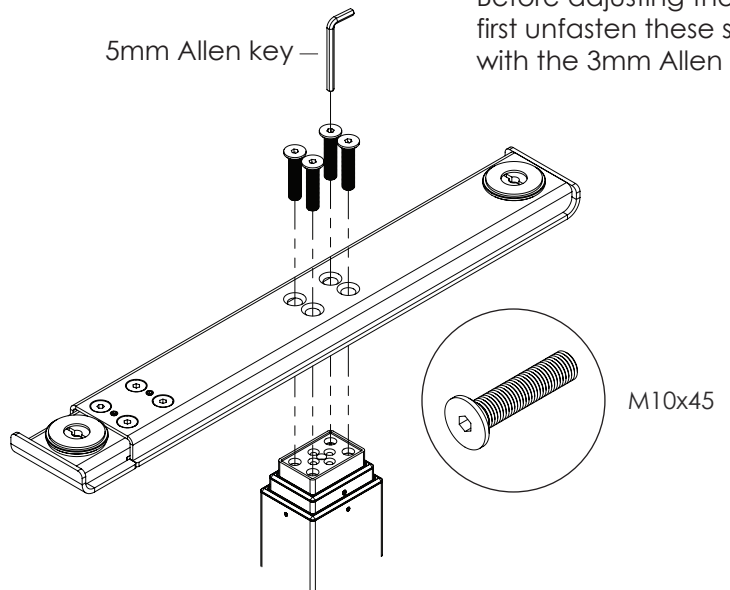

STEP 7

If the table depth is 30" (76cm) or more, expand the top supports on each side.

- Remove the two machine screws from the top support using the 4mm Allen key.
- Slide the top supports to the longer length, as shown below.
- Re-install the machine screws in the forward two holes of the top support.

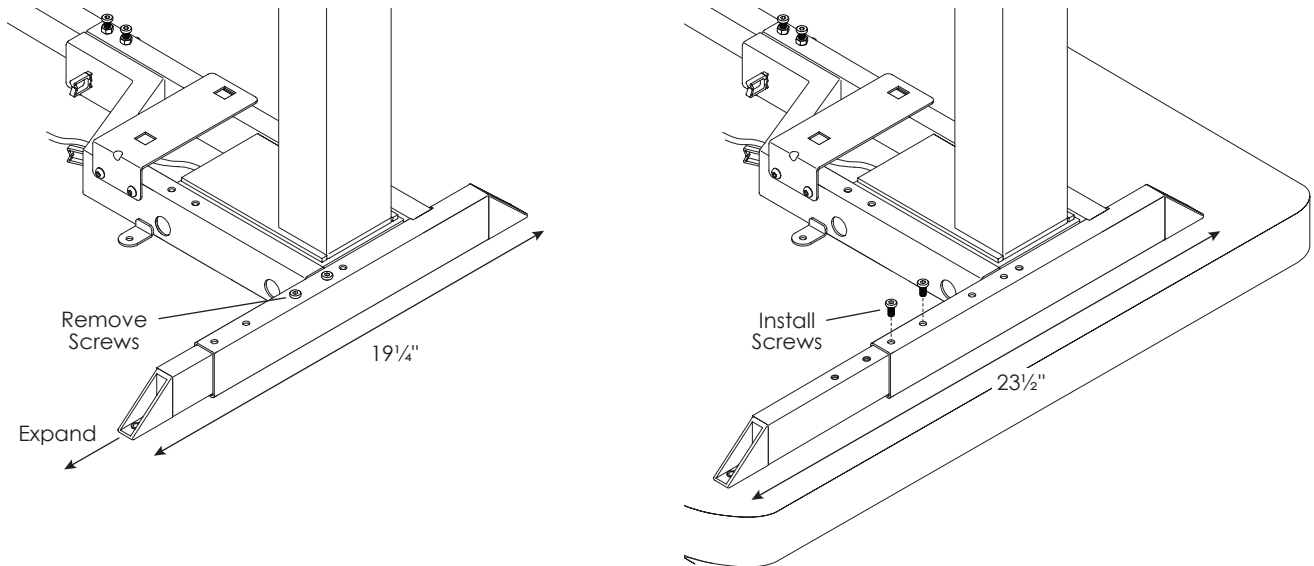
**STEP 8**

Once the frame is in its final position, attach it to the work surface using the Ø5x18 screws (10 total required).

- Attach the screws through the mounting tabs on the frame, the mounting tabs on the inner piece of the cross channel, and the holes at the ends of the top supports.
- Use a Phillips screwdriver.

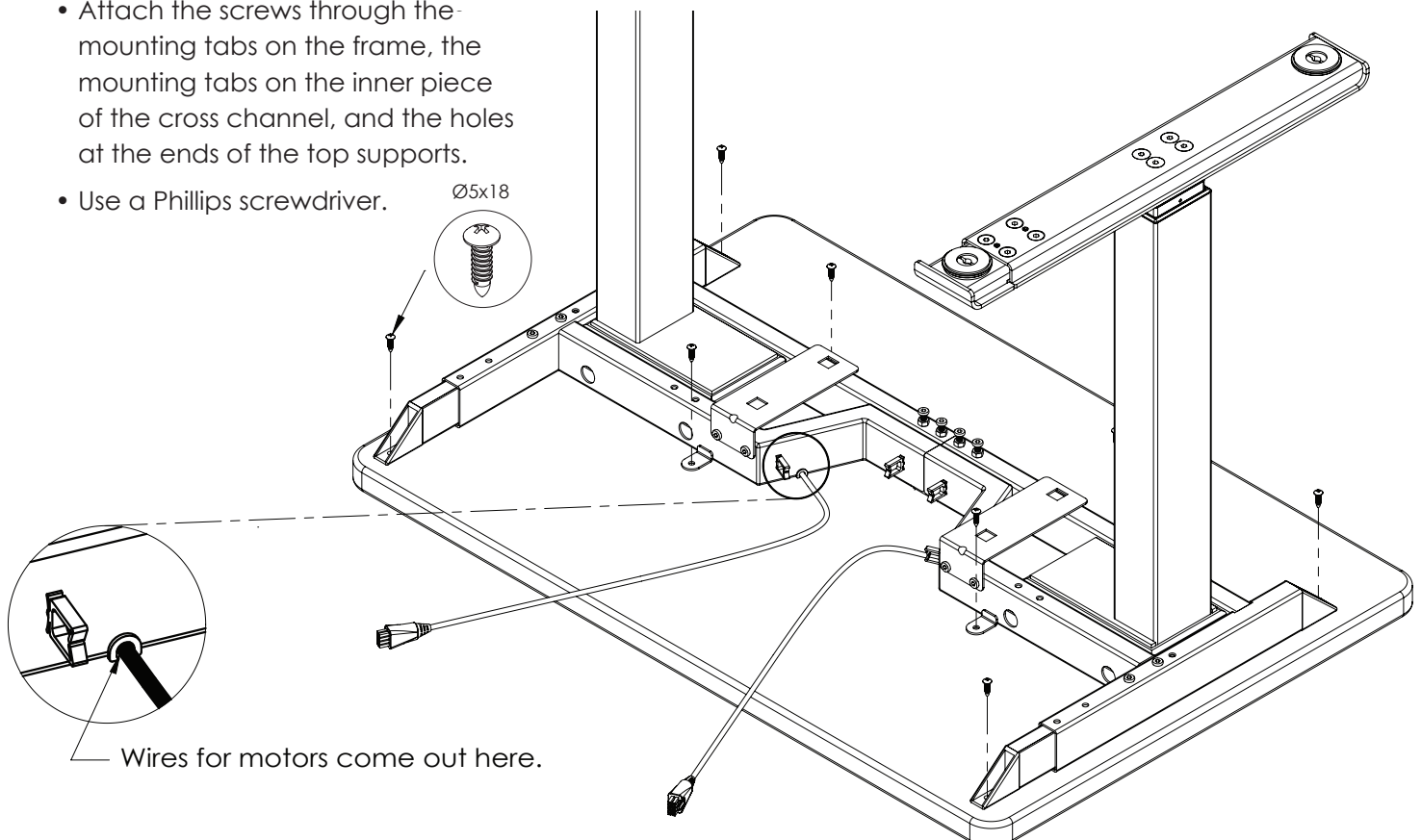

STEP 9

Attach the control unit bracket to the frame and the control unit to the work surface.

- Secure the control unit bracket to the frame using two M6x15 screws and a 4mm Allen key.
- The bracket may be attached on either side of the frame. (Note that the digital keypad will be attached on the same side.)
- Attach the control unit under the bracket using Ø5x18 wood screws. The motor cable and keypad ports should face the center of the table, as shown.
- Allow 2¼" (57mm) between the back of the control unit and the top support to allow room for power cord attachment.

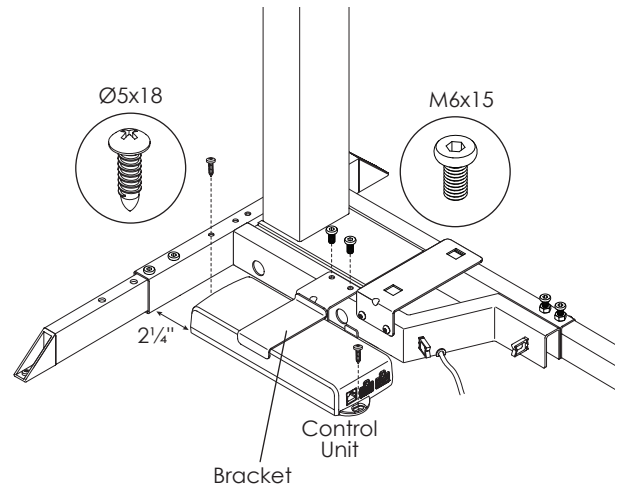
**STEP 10**

Attach the digital keypad at the front edge of the work surface.

- Use the two Ø4x23 wood screws.
- Attach the keypad on the same side as the control unit.

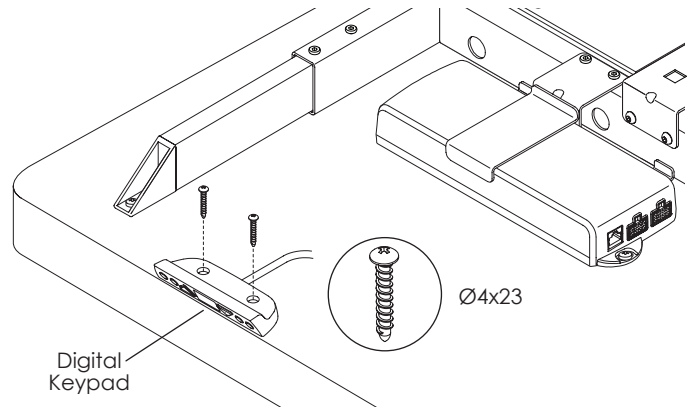
**STEP 11**

Make connections to the control unit.

- Connect the cable from the digital keypad.
- Connect the motor cables from the motors.
- Connect the power cord to the control unit.
- Plug the power cord into an AC outlet.

CAUTION: Do not operate the table until after "zero setting" the system. See following step.

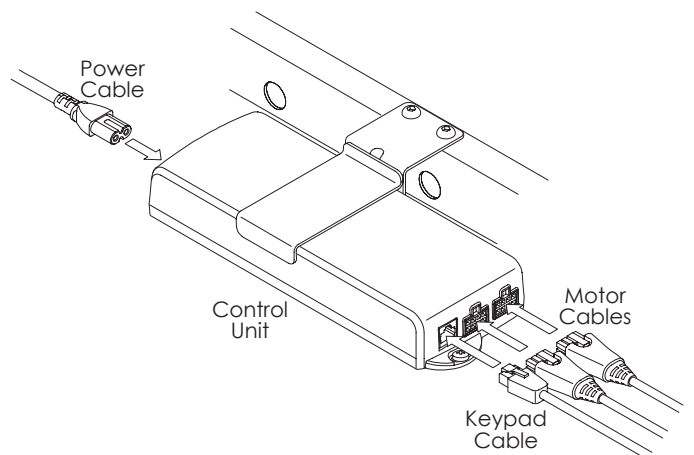

STEP 12

“Zero set” the system before testing operation. (Note that with the table and keypad upside-down, the UP ▲ and DOWN ▼ buttons face their opposite directions.)

- Press and hold the UP ▲ and DOWN ▼ buttons at the same time. Continue to hold the buttons. The legs will lower until they reach their bottom point.
- Release the buttons once the system beeps. If it does not beep, continue to hold the buttons for 3 seconds after the legs reach the lowest point. The system is now “zero set.”
- Press the UP ▲ and DOWN ▼ buttons to test operation. End your test with the legs lowered and unplug the power cord.
- If there are problems with operation, check that all cable and cord connections are secure. If problems continue, call ESI Customer Service.

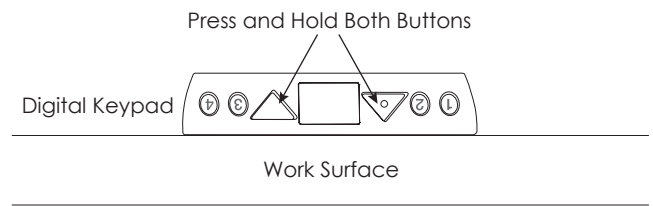
**STEP 13**

Use the pre-installed cable clips plus the additional ones provided to secure the cables in position.

- Cables must not interfere with table operation.
- Cables must not interfere with the user.

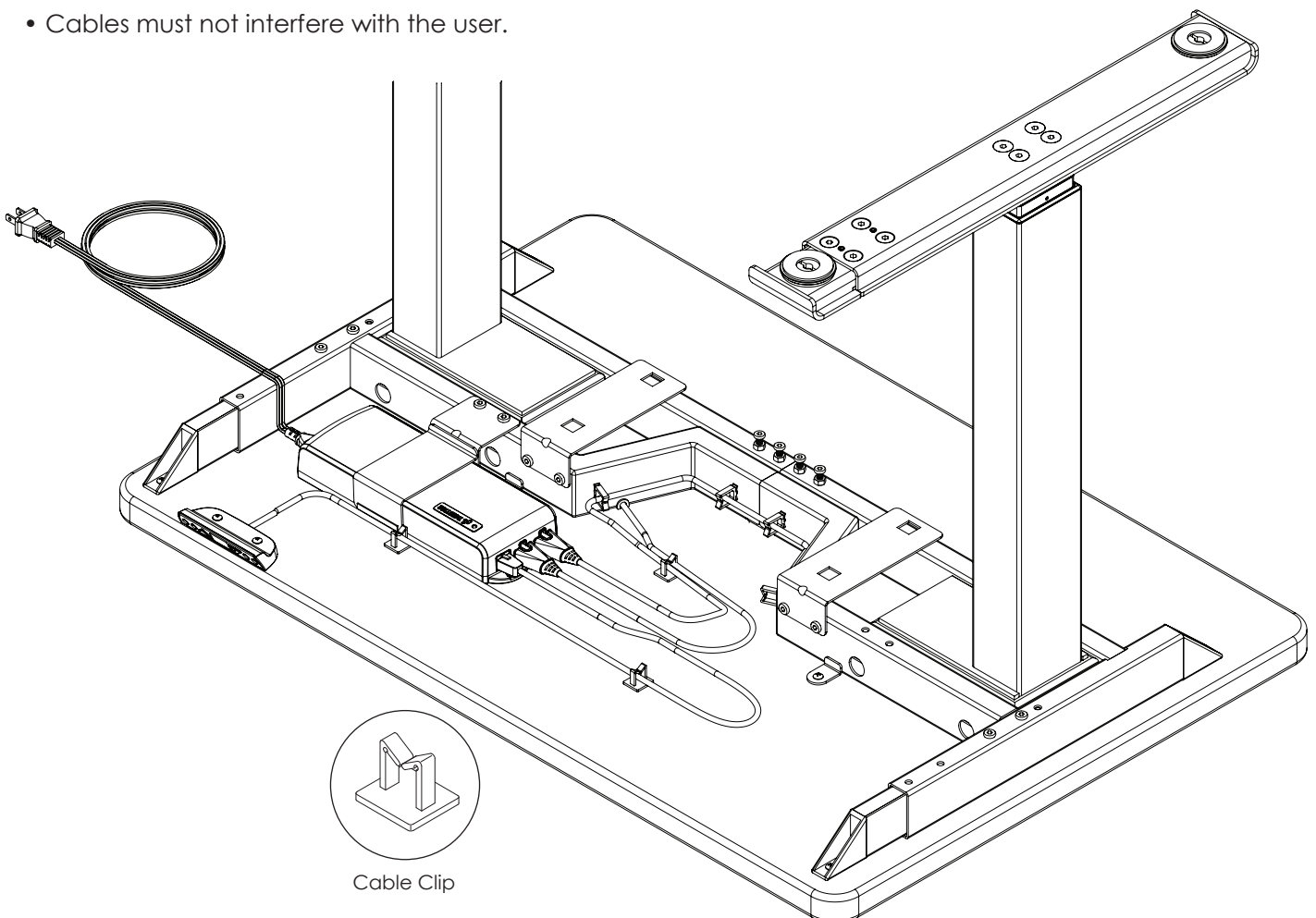

STEP 14

With the assistance of a helper, turn the table upright and place it in its final position.

IMPORTANT: There must be 1" (25mm) of clearance on all sides of the work surface (and other moving parts) to ensure free, unobstructed movement.

- Adjust the leveling glides on the feet to level the work surface, if necessary.
- Plug the power cord into an AC outlet.
- See the following page for operating procedures.

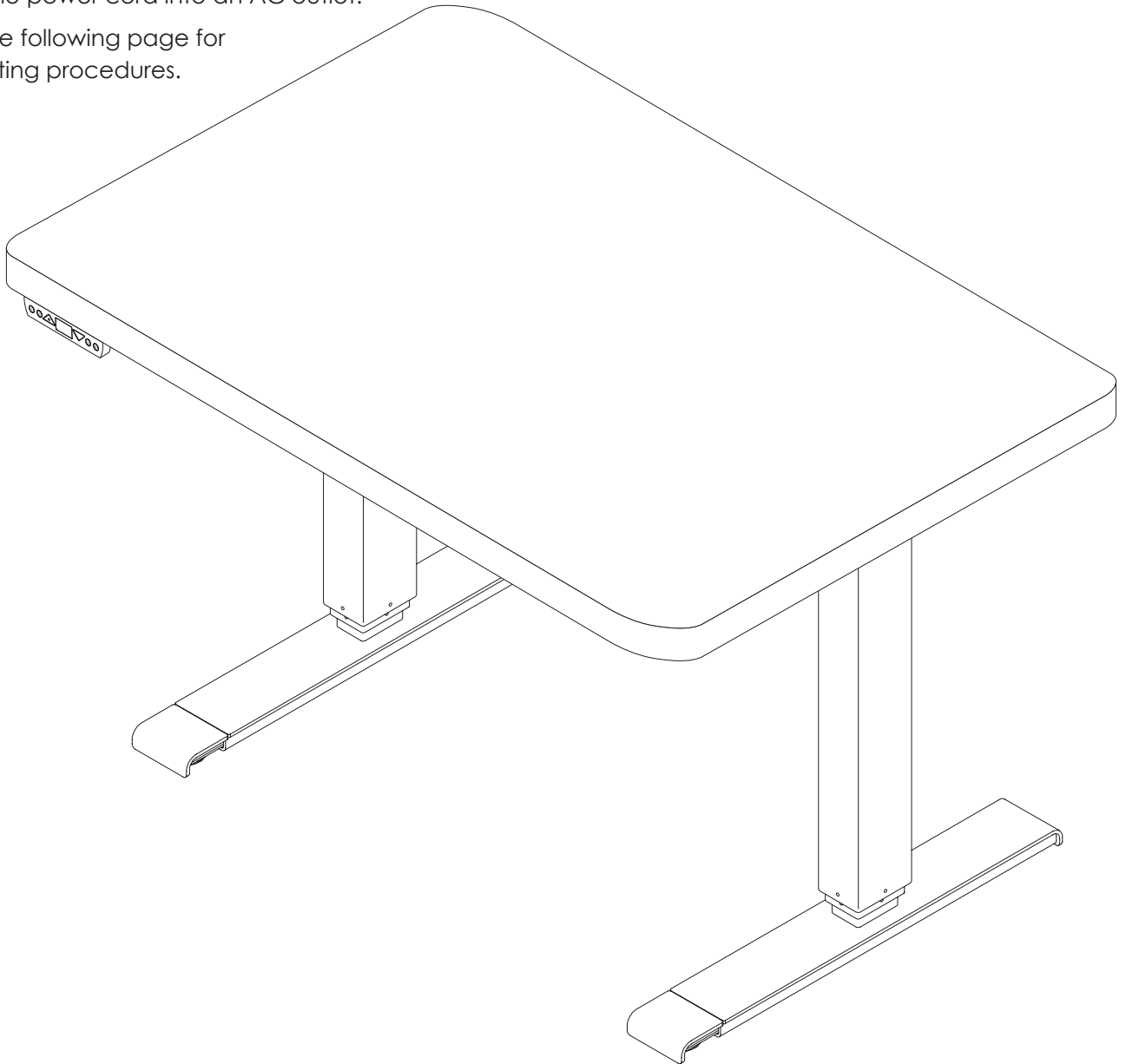

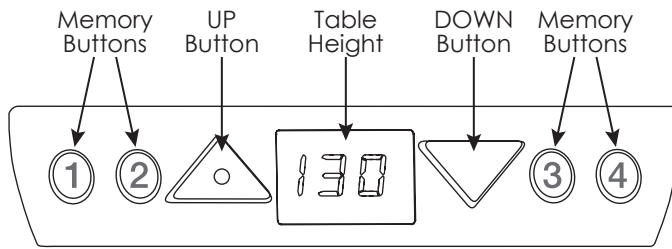

CAUTION: The “zero setting” procedure must be completed before operating the table. See Step 16 on page 8.

GENERAL OPERATION

Move the table up or down by pressing UP ▲ or DOWN ▼ until the work surface reaches the desired height.

The table will continue to move up or down until you release the button or until the maximum or minimum height is reached.

IMPORTANT: Be sure there are no obstructions to table movement along its full range of travel.

SETTING A MEMORY POSITION

The memory buttons allow you to save up to four specific positions of the work surface. To set a memory position:

- Adjust the work surface to the position you want to save. (The display on the control pad shows the work surface height.)
- Press the UP ▲ button and one of the memory buttons at the same time for 3 to 5 seconds.
- The display will flash “P” and the number of the memory button.
- Repeat for the other memory buttons, if desired.

MOVING TO A MEMORY POSITION

- Press and hold the desired memory button.
- The work surface will move to the preset position.

Table movement stops when you release the UP ▲ or DOWN ▼ button.

Example: Press the UP ▲ button and memory button number 3 at the same time for 3 to 5 seconds. The display will flash “P3” indicating that the current table position has been saved in memory.

Continue to press the memory button until table movement stops.



800.833.3746 | esiergo.com

ALL-FLEX™ 3 LEG ELECTRIC TABLE BASE

Model FLEX3-SLV-V1
Model FLEX3-BLK-V1
Model FLEX3-WHT-V1

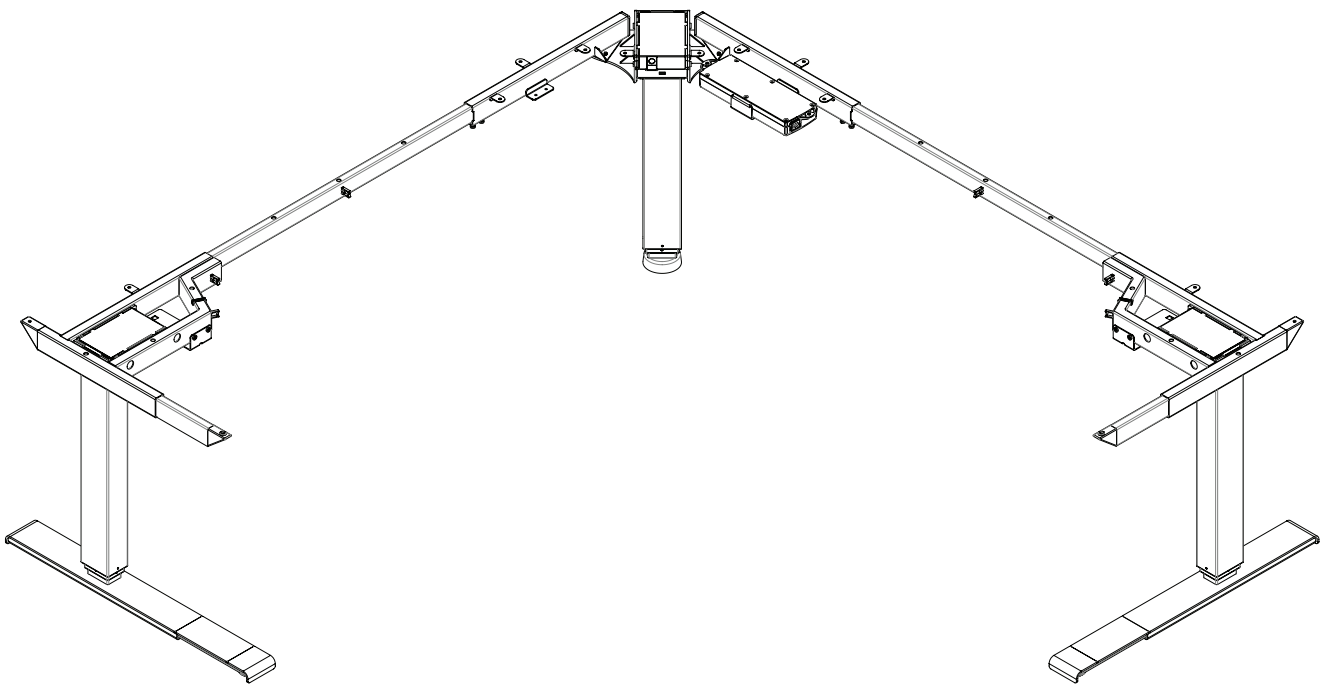

FLEX3-V1 Rev B 11/17



ASSEMBLY AND OPERATION

PLEASE REVIEW these instructions before beginning the assembly procedures. Check that all the parts shown below were provided with your order. Contact your supplier if any materials are missing. Do not discard the packaging until content that the product operates to your satisfaction.

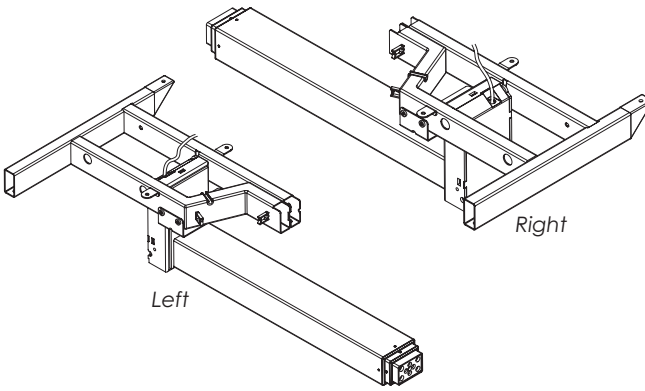
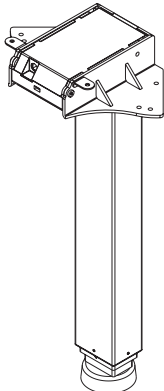
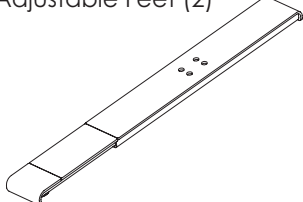
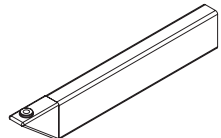
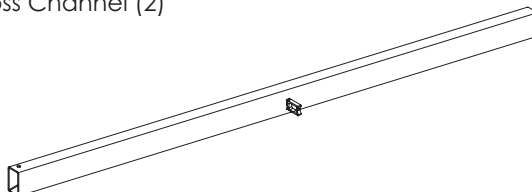
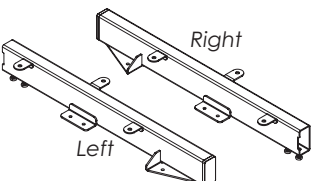
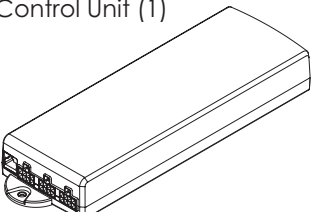
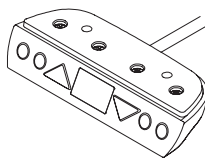
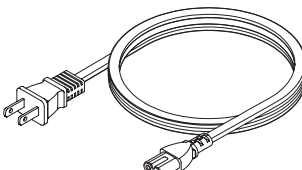
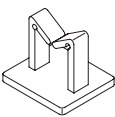
PARTS AND TOOLS PROVIDED

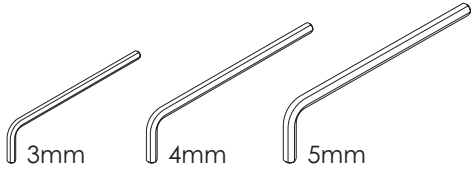
| | | | |
|---|---|---|---|
| <p>Leg Hinged to Frame (2)</p>  | <p>Center Leg (1)</p>  | <p>Adjustable Feet (2)</p>  | |
| <p>Side Leg Top Support (2)</p>  | <p>Cross Channel (2)</p>  | <p>Center Leg Top Support (2)</p>  | |
| <p>Control Unit (1)</p>  | <p>Digital Keypad (1)</p>  | <p>Power Cable (1)</p>  | <p>Cable Clip (4)</p>  |
| <p>Fasteners</p>  <p>M10x45 (8) M6x15 (14) M5x18 (18) M4x23 (2)</p> | | <p>Allen Keys (1 each)</p>  <p>3mm 4mm 5mm</p> | |

NOTE: This install requires a power tool or cordless drill. Except for the hex head screws, this is **not** a hand tool install.

ADDITIONAL TOOLS REQUIRED

- #2 Phillips drill bit
- Power Driver

CAUTION: Always check that screws used to attach components to the worksurface are not too long for the thickness of the surface.

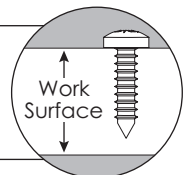

STEP 1

With the worksurface facing down on a soft, clean surface, arrange the leg columns and center leg top supports as shown.

- Unfold the hinged side legs and place them motor-side down at the ends of the worksurface.
- Place the center leg motor side down near the 90° or 120° angle of the table.
- The mounting tabs on the leg columns and top supports must be face down so that they are against the worksurface.

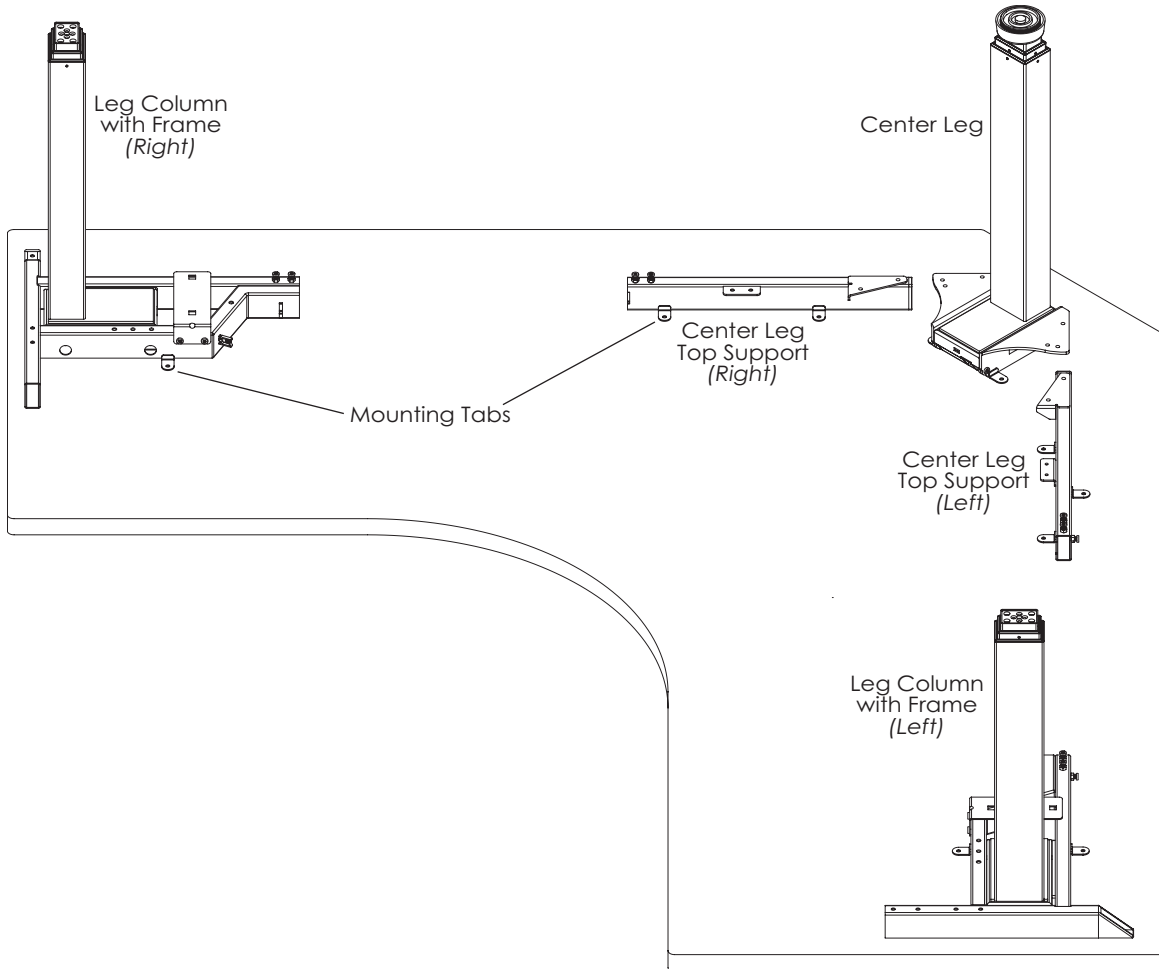
**STEP 2**

Lock the side leg columns in the upright position.

- Use the 4mm Allen key to install M6x15 hex head screws into the frame and motor.

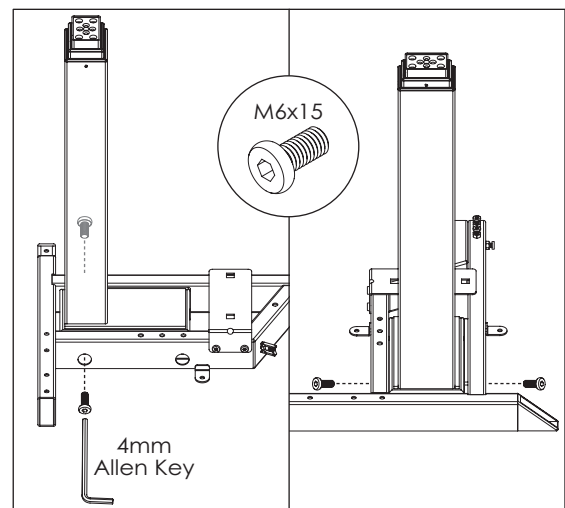

STEP 3

Route the side column motor cables under the notch on the angled portion of each frame.

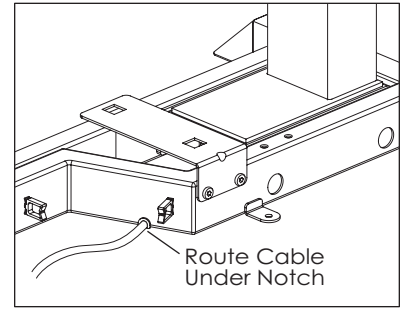

STEP 4

Install the cross channels.

- Insert each cross channel into the frame and center leg top support.
 - The cross channel fits into the rear opening on the frame, under the set screws.
- Slide the top supports under the center leg brackets. Align the holes on the top supports with the 90° or 120° holes in the brackets. See the illustration below.
- Position each cross channel so that its center line is centered between the frame and the top support.
- The MAX lines must not extend beyond the frame and top support.

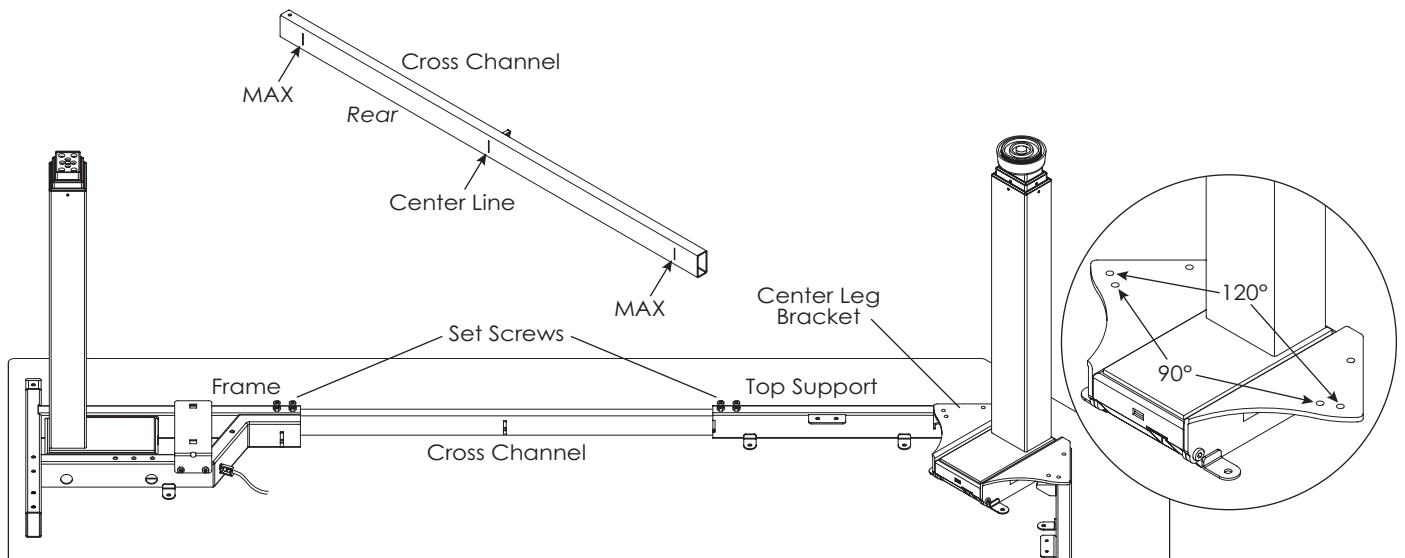

STEP 5

Attach the top supports to the center leg brackets.

- Use the 4mm Allen key and four M6x15 hex head screws.
- Use the inner hole on the bracket for 90° tables and the outer hole for 120° tables.

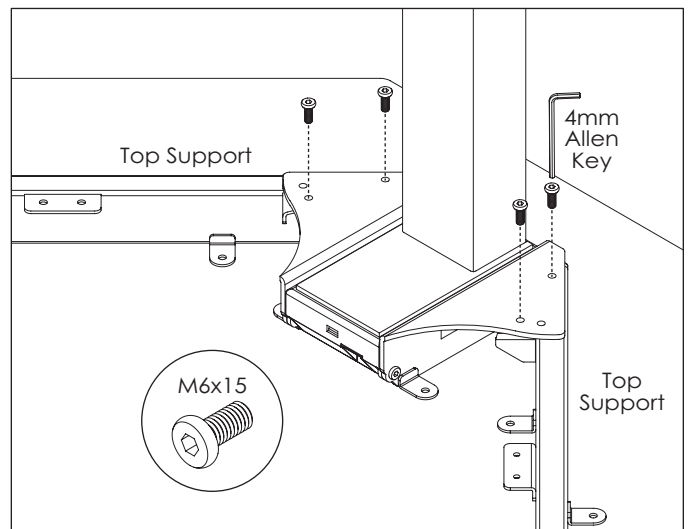

STEP 6

Attach the two-piece side top supports. One piece is attached to the frame; the other piece is separate.

- Insert the separate piece of the top support into the top support attached to the frame.
- Align the holes on the inserted piece with the rear set of two holes on the integral top support if the table depth is less than 30" (76cm). Align the holes with the front set if the table depth is 30" or more.

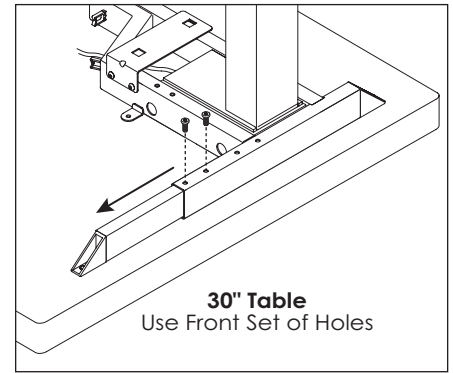
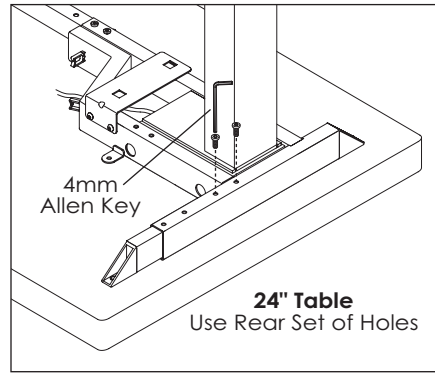
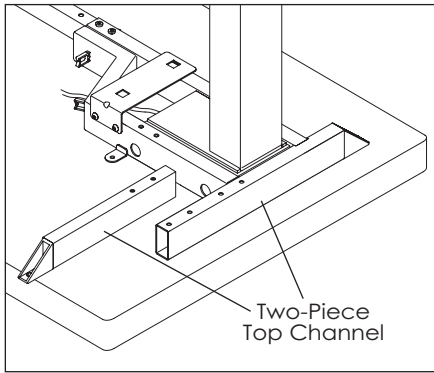

STEP 7

Change the length of the adjustable feet, if necessary.

- The length of the feet may be either 22" (55.9cm) or 28" (71.2cm). The feet are shipped in the 28" length. They should be changed to the shorter length if the worksurface depth is less than 28".

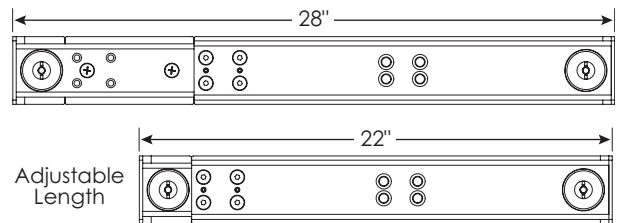

- To change the length to 22":
 - Remove the two plastic Phillips screws holding the adjustment plate in place.
 - Use the 5mm Allen key to remove the four hex head screws.
 - Use the 3mm Allen key to loosen the two set screws.
 - Slide the feet to the 22" length. Reinstall the four hex head screws and tighten the set screws.
- Store unused adjustment plates in the brackets attached to the frame, securing them with the two plastic Phillips screws.

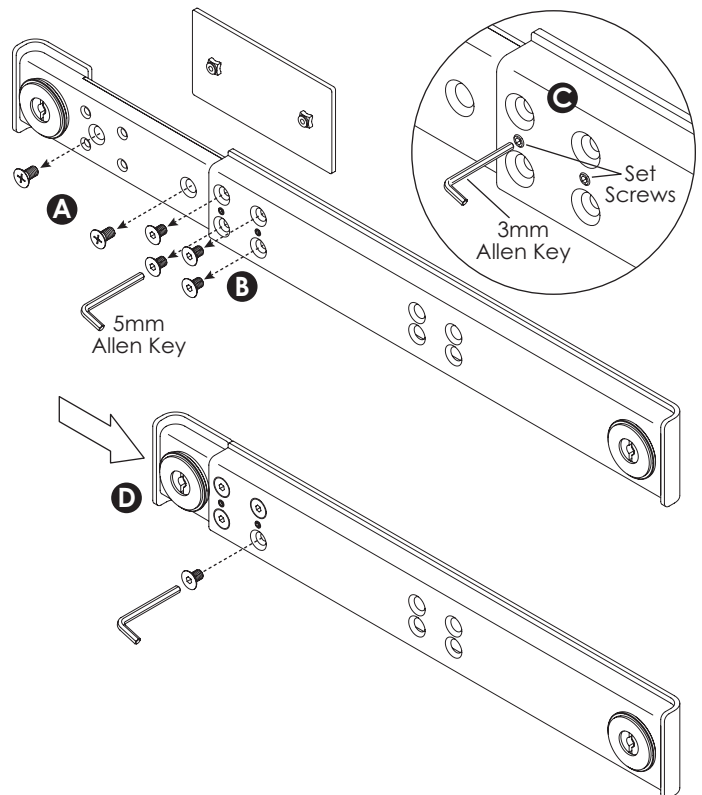
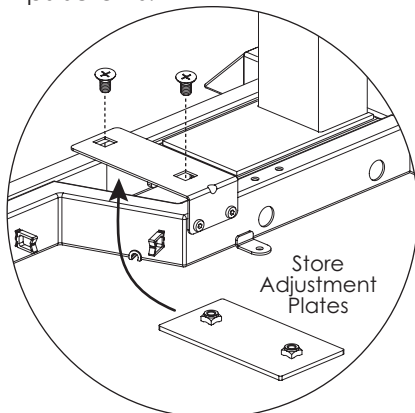

STEP 8

Attach a foot to each of the legs.

- Use four M10x45 screws per foot.
- Tighten the screws with an 5mm Allen key.

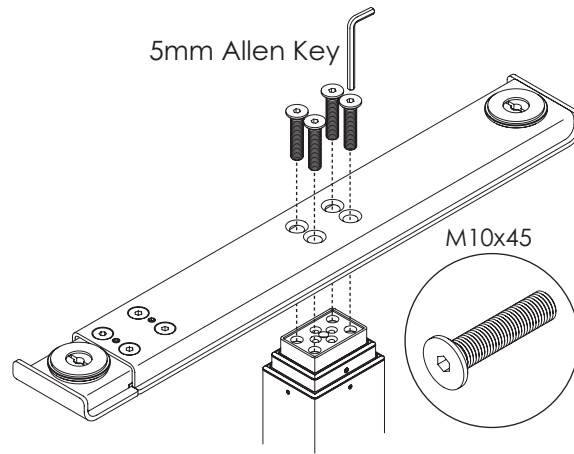
**STEP 9**

Adjust the position of the frame before attaching it to the worksurface.

- Align the rear of the feet with the rear of the table.
- Center the center leg on the 90° or 120° angle.
- Check that the top supports on each side are approximately 1" (25mm) from the ends of the table.
- The rear of the feet should align with the rear of the table. With that alignment, the center leg top supports will be 6½" from the rear of the table.
- Check that each cross channel's center line is centered between the frame and top support, and that the MAX lines do not extend beyond the frame and top support.

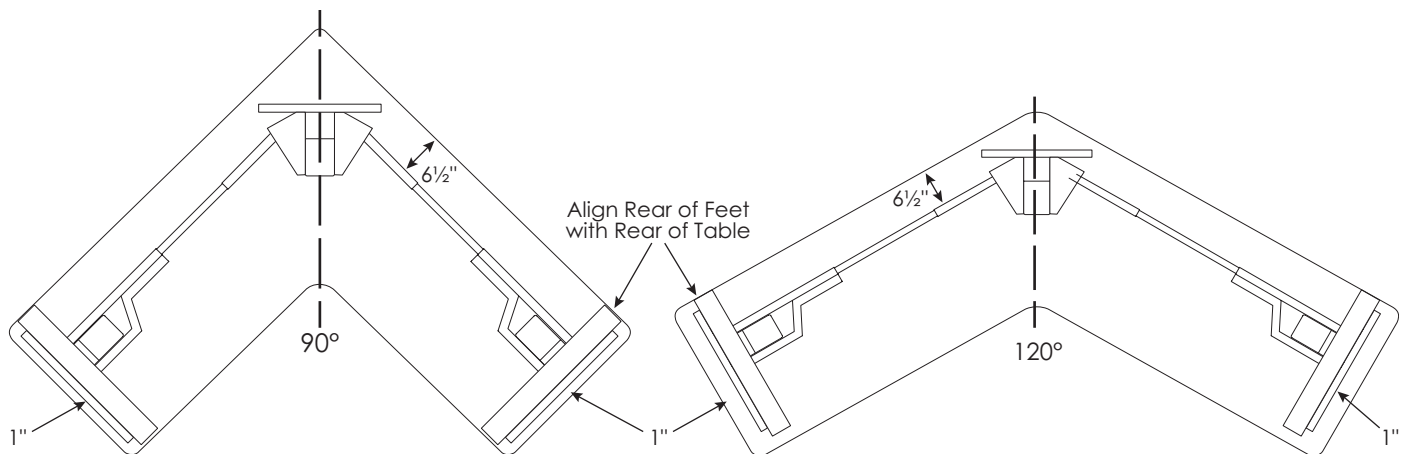

STEP 10

Once the frame is in its final position, attach it to the worksurface using the M5x18 screws (16 total required).

- Attach the screws through the mounting tabs on the frame, center leg column, and center leg top supports, as well as the holes at the ends of the side column top supports.
- Use a power drill with #2 Phillips bit. This is not a hand tool install.
- After attaching the frame, tighten all 12 set screws, as shown below.

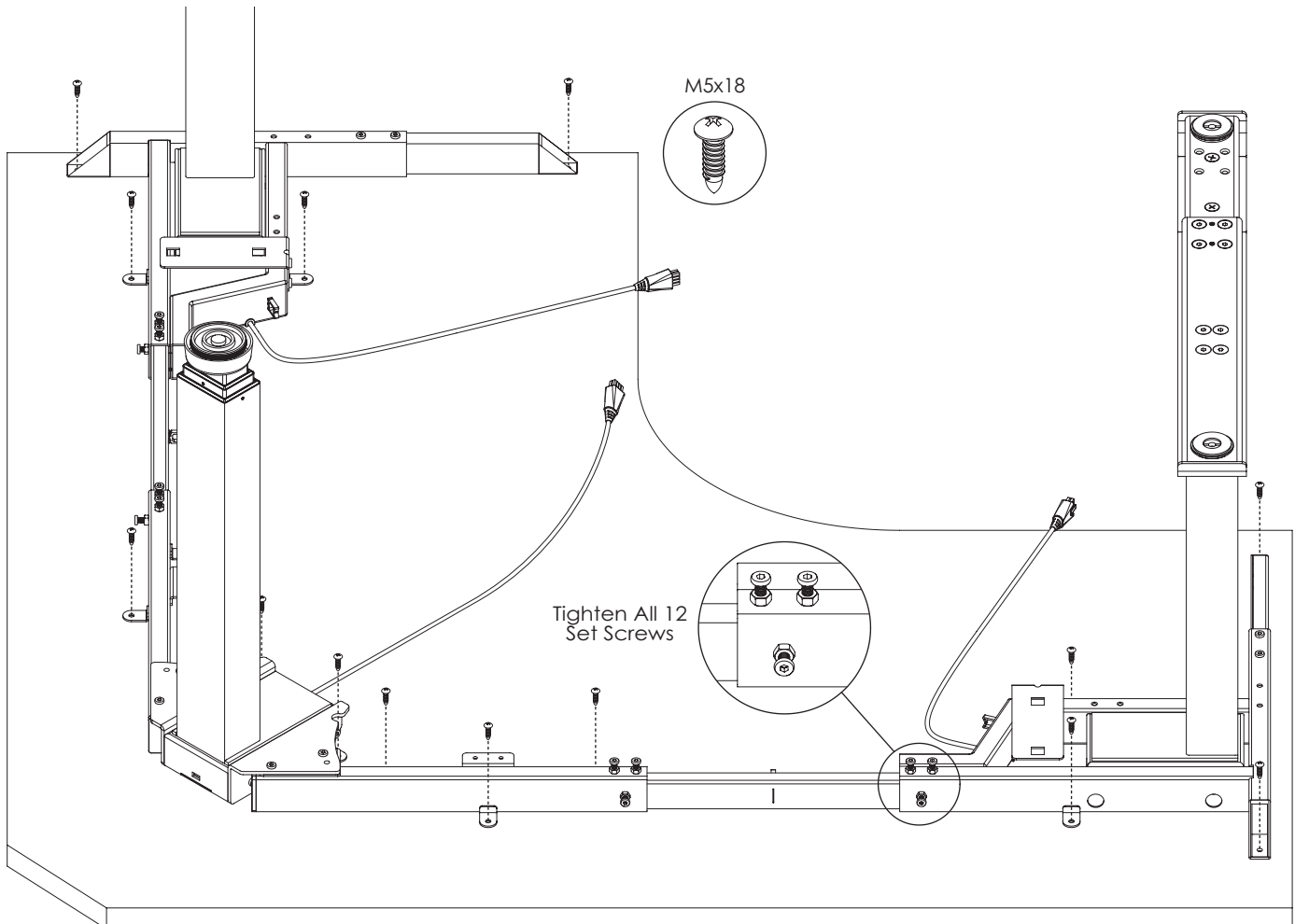
**STEP 11**

Attach the control unit bracket to one of the center leg top supports.

- Secure the control unit bracket to the frame using two M6x15 screws and the 4mm Allen key.
- The bracket may be attached on either side of the center column. (Note that the digital keypad will be attached on the same side.)

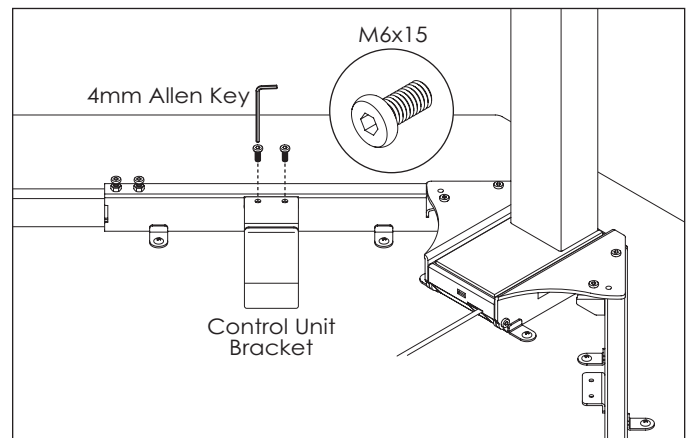

STEP 12

Attach the control unit to the worksurface.

- Slide the control unit under the bracket and attach it using M5x18 wood screws. The motor cable and keypad ports should face away from the center column.
- Allow at least 2¼" (57mm) between the back of the control unit and the center column assembly to allow room for power cord attachment.

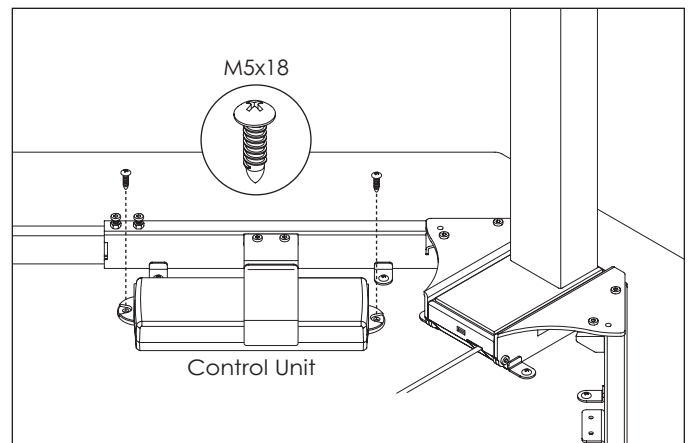
**STEP 13**

Attach the digital keypad flush with the front edge of the worksurface.

- Use the two M4x23 wood screws.
- Attach the keypad on the same side as the control unit.

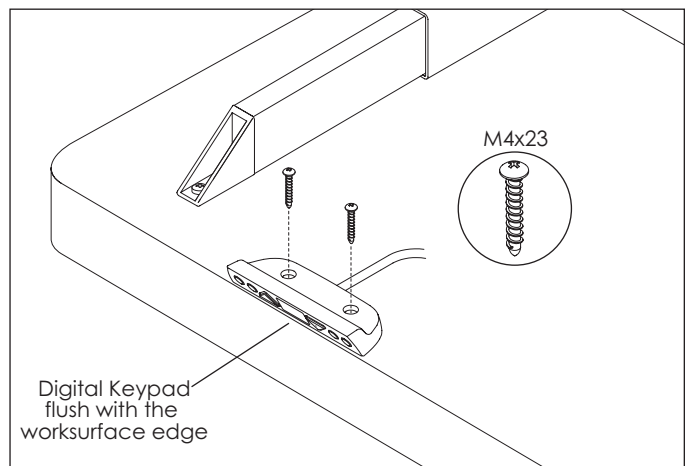
**STEP 14**

Make connections to the control unit.

- Connect the cable from the digital keypad.
- Connect the motor cables from the three motors.
- Connect the power cord to the control unit.
- Plug the power cord into an AC outlet.

CAUTION: Do not operate the table until after "zero setting" the system. See the following step.

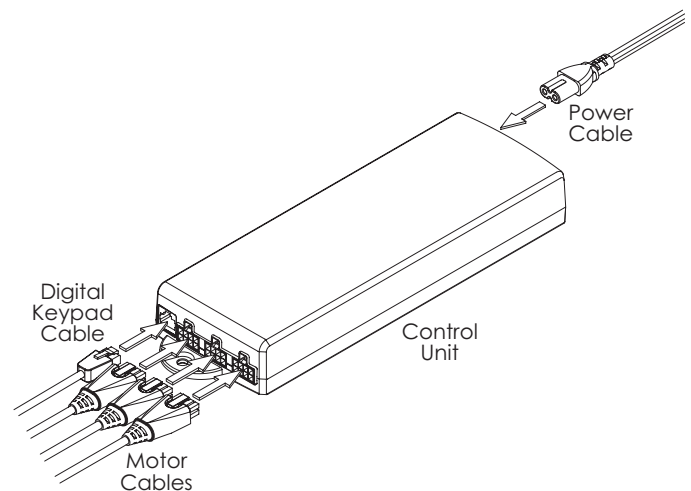

STEP 15

“Zero set” the system before testing operation. (Note that with the table and keypad will be upside-down, the UP ▲ and DOWN ▼ buttons face their opposite directions.)

- Press and hold the UP ▲ and DOWN ▼ buttons at the same time. Continue to hold the buttons. The legs will retract until they reach their bottom point.
- Release the buttons once the system beeps. If it does not beep, continue to hold the buttons for 3 seconds after the legs reach the lowest point. The system is now “zero set.”
- Press the UP ▲ or DOWN ▼ buttons to test operation. End your test with the legs lowered and unplug the power cord.
- If there are problems with operation, check that all cable and cord connections are secure. If problems continue, call ESI Customer Service.

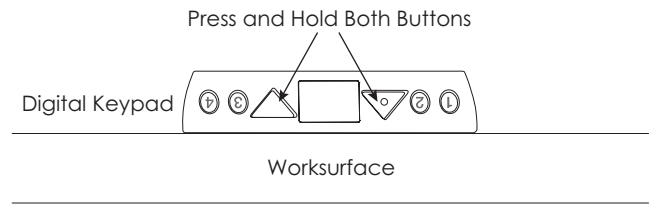
**STEP 16**

Use the pre-installed cable clips plus the additional clips provided to secure the cables in position.

- Cables must not interfere with table operation.
- Cables must not interfere with the user.

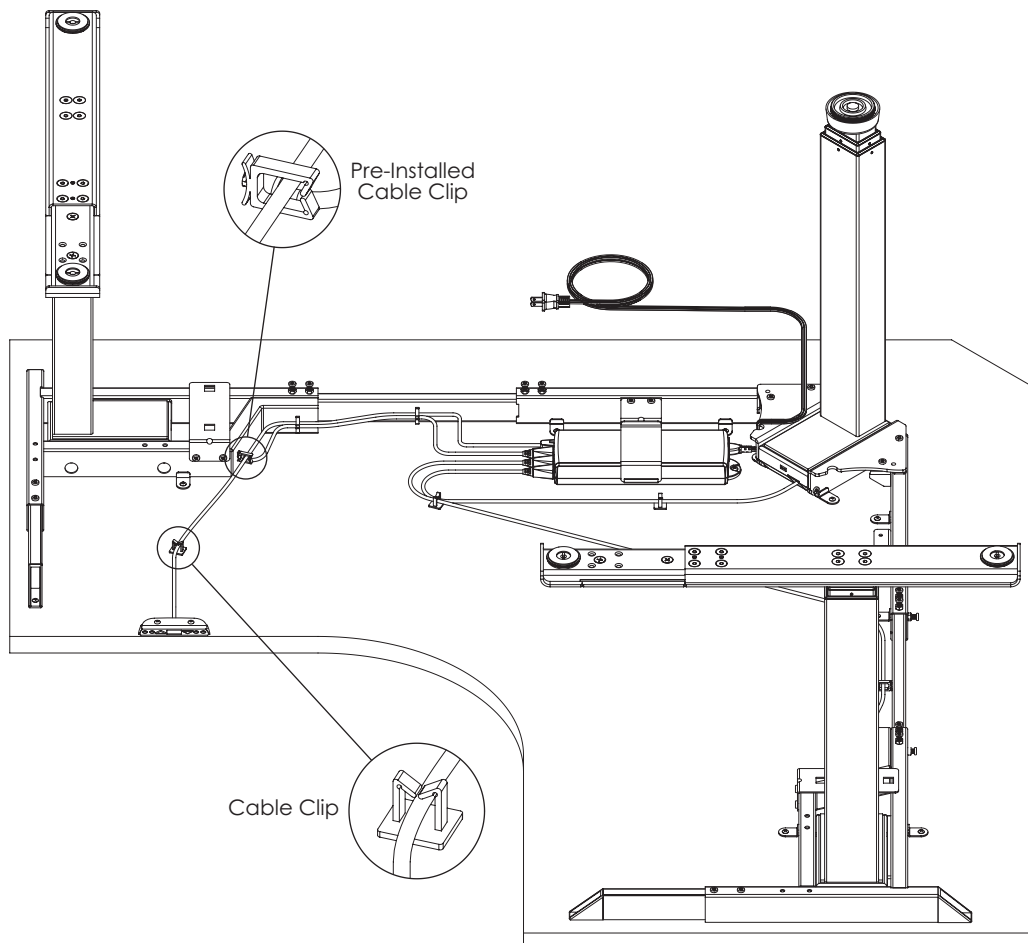

STEP 17

With the assistance of a helper, turn the table upright and place it in its final position.

IMPORTANT: There must be 1" (25mm) of clearance on all sides of the worksurface (and other moving parts) to ensure free, unobstructed movement.

- Adjust the leveling glides on the feet to level the worksurface, if necessary.
- Plug the power cord into an AC outlet.
- See the following page for operating procedures.

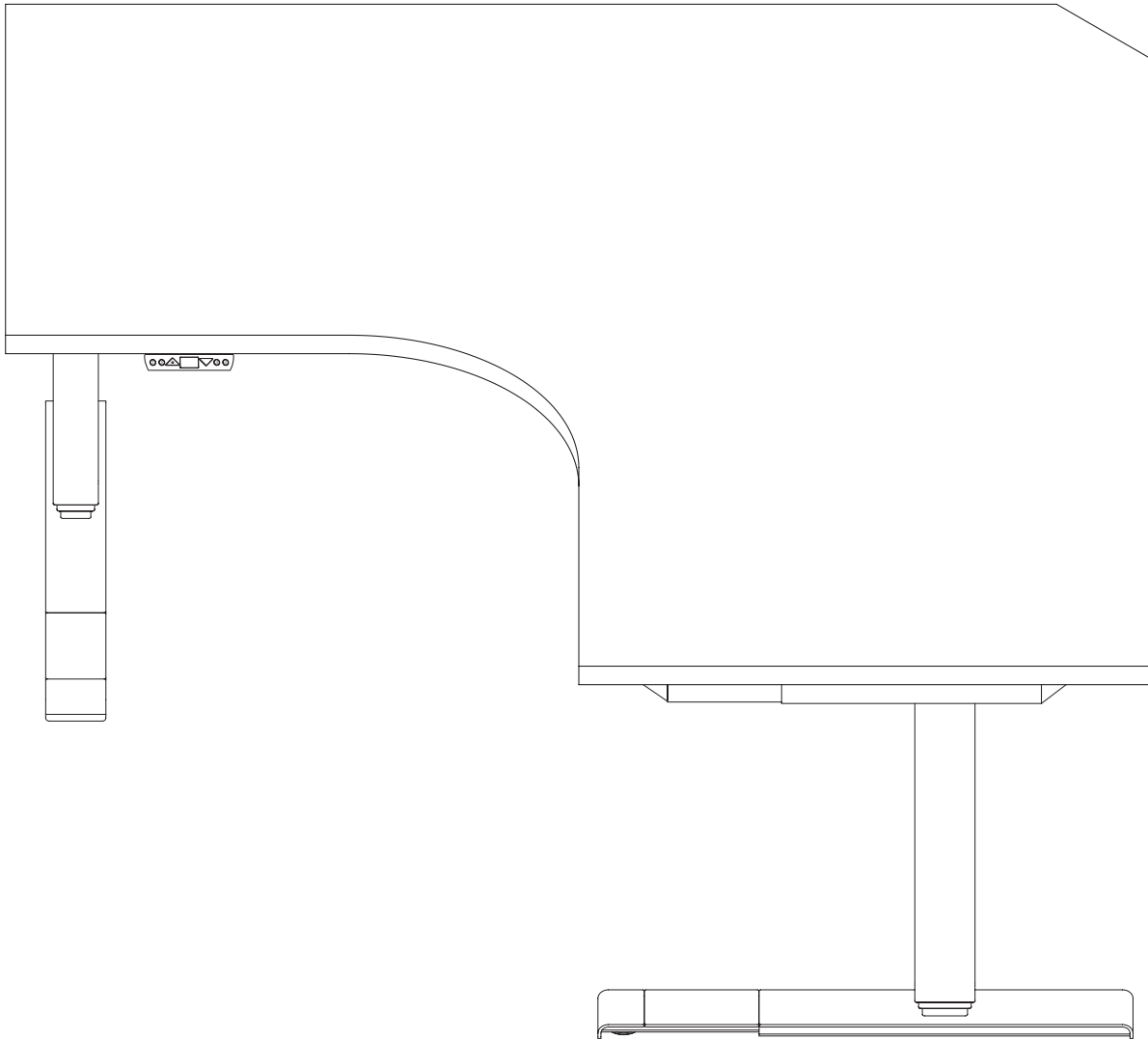

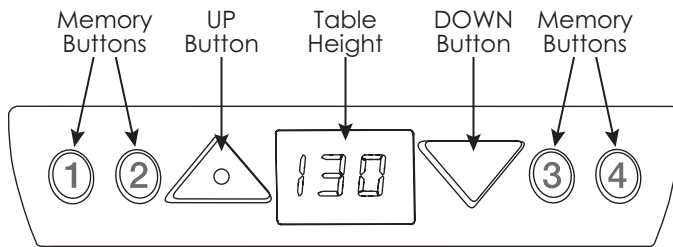

CAUTION: The “zero setting” procedure must be completed before operating the table. See Step 15 on page 9.

GENERAL OPERATION

Move the table up or down by pressing UP ▲ or DOWN ▼ until the worksurface reaches the desired height.

The table will continue to move up or down until you release the button or until the maximum or minimum height is reached.

IMPORTANT: Be sure there are no obstructions to table movement along its full range of travel.

SETTING A MEMORY POSITION

The memory buttons allow you to save up to four specific positions of the worksurface. To set a memory position:

- Adjust the worksurface to the position you want to save. (The display on the control pad shows the worksurface height.)
- Press the UP ▲ button and one of the memory buttons at the same time for 3 to 5 seconds.
- The display will flash “P” and the number of the memory button.
- Repeat for the other memory buttons, if desired.

MOVING TO A MEMORY POSITION

- Press and hold the desired memory button.
- The worksurface will move to the preset position.

Table movement stops when you release the UP ▲ or DOWN ▼ button.

Example: Press the UP ▲ button and memory button number 3 at the same time for 3 to 5 seconds. The display will flash “P3” indicating that the current table position has been saved in memory.

Continue to press the memory button until table movement stops.



800.833.3746 | esiergo.com