

EPPA MONITOR ARM

Model EPPA-XXX

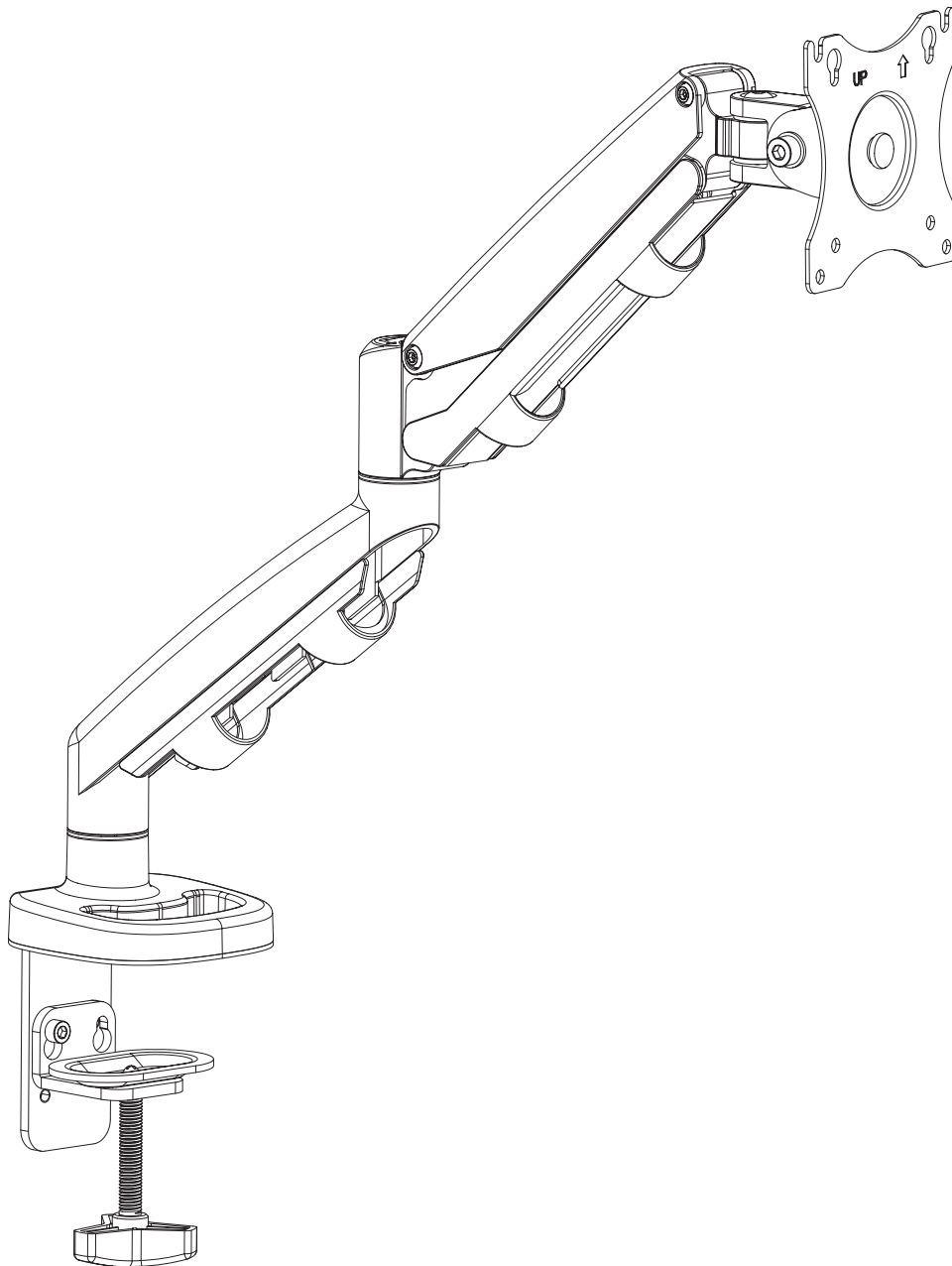









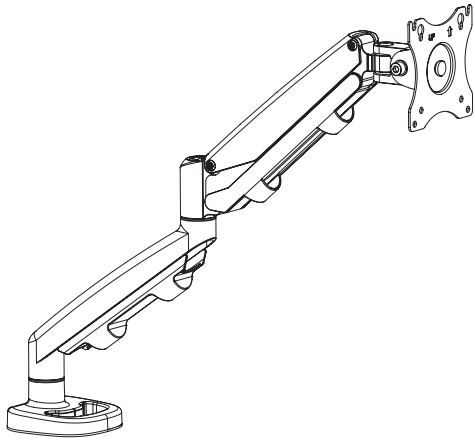
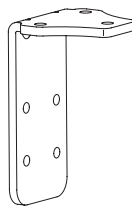

EPPA Rev A 10/17

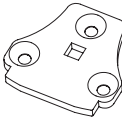
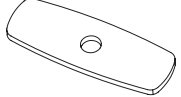
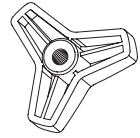

ASSEMBLY AND ADJUSTMENT

PLEASE REVIEW these instructions before beginning the assembly and adjustment procedures. Check that all the parts and tools listed below were provided with your order. Contact your supplier if any materials are missing. Do not discard the packaging until satisfied that the product operates to your satisfaction.

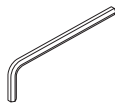
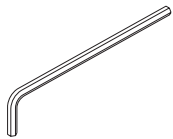
PARTS AND TOOLS PROVIDED

<p>Base and Monitor Arm Assembly (1)</p> 	<p>Clamp L-Bracket (1)</p> 	<p>Clamp (1)</p> 	<p>Clamp Pad (1)</p> 	
	<p>Grommet Bolt (1)</p>  <p>M8x104</p>	<p>Grommet Mount Plate (1)</p> 	<p>Grommet Bar (1)</p> 	
<p>Grommet Knob (1)</p> 	<p>Flat Head Screw (3)</p>  <p>M6x12</p>	<p>Socket Cap Screw (2)</p>  <p>M6x10</p>	<p>Monitor Screw (4)</p>  <p>M4x12</p>	<p>Monitor Screw (4)</p>  <p>M5x12</p>
<p>Monitor Screw Washer (4)</p>  <p>D5</p>	<p>4mm Allen Key (1)</p> 	<p>6mm Allen Key (1)</p> 	<p>Plastic Cap (1)</p> 	

CAUTION: Hand-tighten screws only.

ADDITIONAL TOOLS REQUIRED

- Phillips screwdriver

Two Base Assembly Attachment Methods

• **Clamp method.** The base assembly is clamped to a table or desk surface that is between 3/8" (10mm) and 3/4" (85mm) thick. See below.

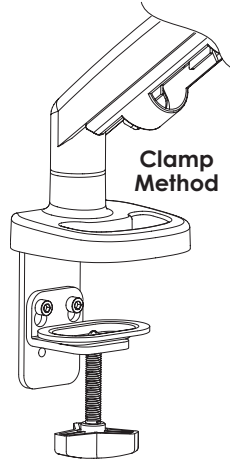

• **Grommet method.** The base assembly is secured through a grommet hole in the work surface. Surface thickness must be between 3/8" (10mm) and 3/4" (85mm). See page 4.

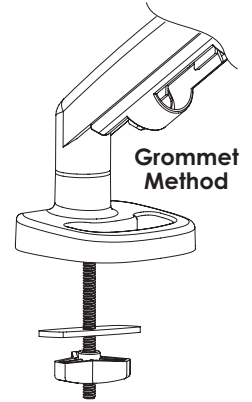

Clamp Method

With the clamp method, the clamp L-bracket, clamp, and clamp pad are assembled to the base.

1. Attach the clamp L-bracket to the underside of the base. Use the three M6x10 flat head screws and the 4mm Allen key.
2. Peel the adhesive backing from the clamp pad and attach the pad to the base and L-bracket.
3. Attach the clamp to the clamp L-bracket using the two M6x10 socket cap screws and the 5mm Allen key.
 - A. Attach the clamp to the top two holes if the thickness of the work surface is between 3/8" (10mm) and 2 1/8" (55mm).
 - B. Attach the clamp to the bottom two holes if the thickness of the work surface is between 2 1/8" (55mm) and 3/4" (85mm).

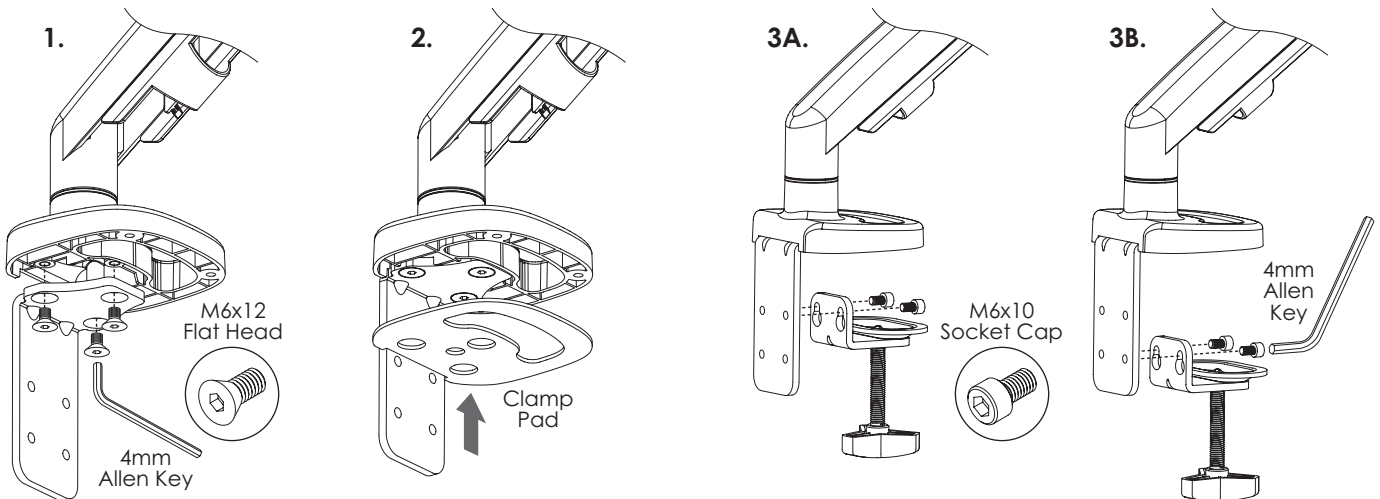

Install Base Assembly

- Clamp the base assembly to the work surface in the desired position. Be sure to tighten the knob securely.
- Proceed to "Monitor Installation" on page 5.

Grommet Method

This method can be used for worksurfaces that have a grommet hole in an appropriate position. First, the grommet bolt and grommet mount plate are assembled to the base. Then, with the base assembly placed over the grommet hole, the grommet bar and grommet knob are used to secure the base assembly in position.

1. With the countersunk holes on the bottom, insert the grommet bolt through the top of the grommet mount plate. Attach the plate to the underside of the base using the three M6x12 flat head screws and the 4mm Allen key.
2. Peel the adhesive backing from the clamp pad and attach the pad to the base and grommet mount plate.

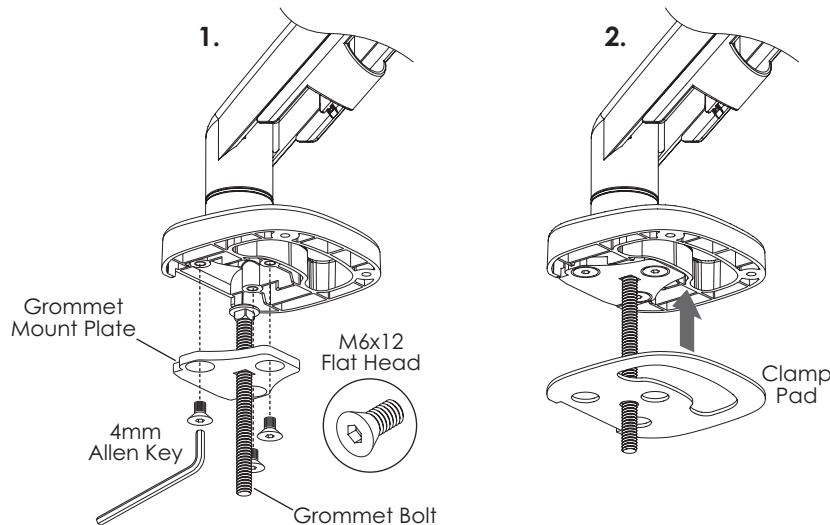
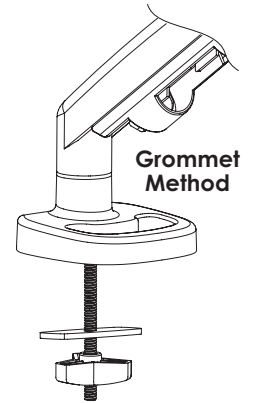

Install Base Assembly

- Place the base assembly over the grommet hole, with the bolt centered.
- Insert the grommet bar onto the grommet bolt and screw on the grommet knob. Tighten the grommet knob securely to hold the base assembly in position.

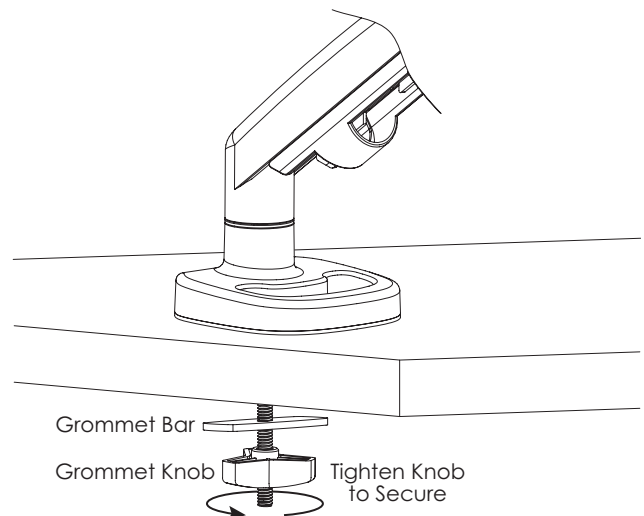
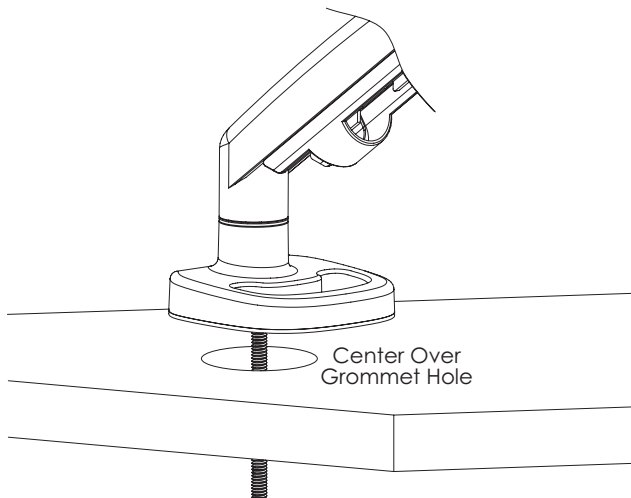

- Proceed to "Monitor Installation" on page 5.

Attach Monitor to VESA Mount

There are two sets of four holes on the VESA mount. One set has holes 3.9" (100mm) apart, the other set has holes 3" (75mm) apart. Use the set that matches the holes on the monitor.

- Place the monitor face down on a flat surface.
- Attach washers and M4x12 or M5x12 screws (depending on monitor hole size) to the top two holes on the back of the monitor. Use a Phillips screwdriver.
- Leave 1/8" to 3/16" (3mm to 5mm) of exposed threads between the washer and monitor.
- Hook the monitor onto the VESA mount, as shown.
- Install and tighten screws and washers into the bottom two holes. Then tighten the top two screws.

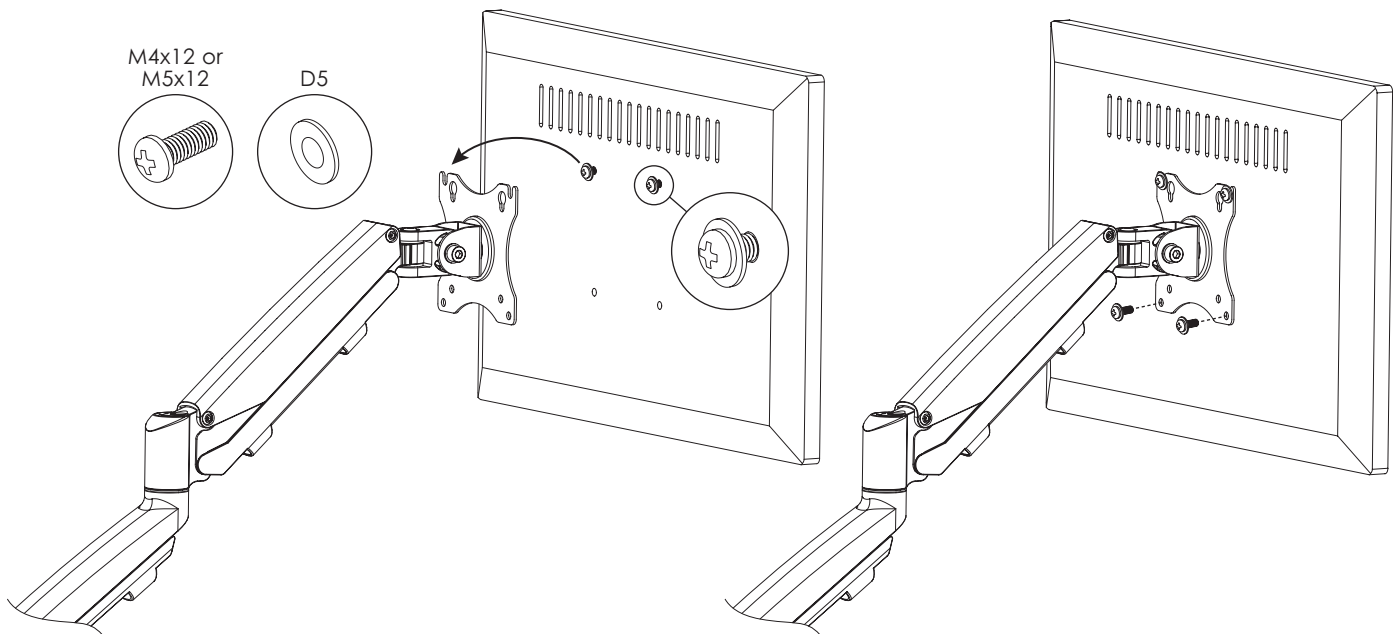

Capture Monitor Cable and Power Cord

Cable covers on the underside of the monitor arm are used to neatly organize the monitor cable and power cord.

Remove Cable Covers

- Slide the lower cable cover up toward the monitor to remove it. Do not attempt to snap it off.
- Slightly pull apart the upper and lower ends of the other cable cover to remove it from mounting holes on the monitor arm.

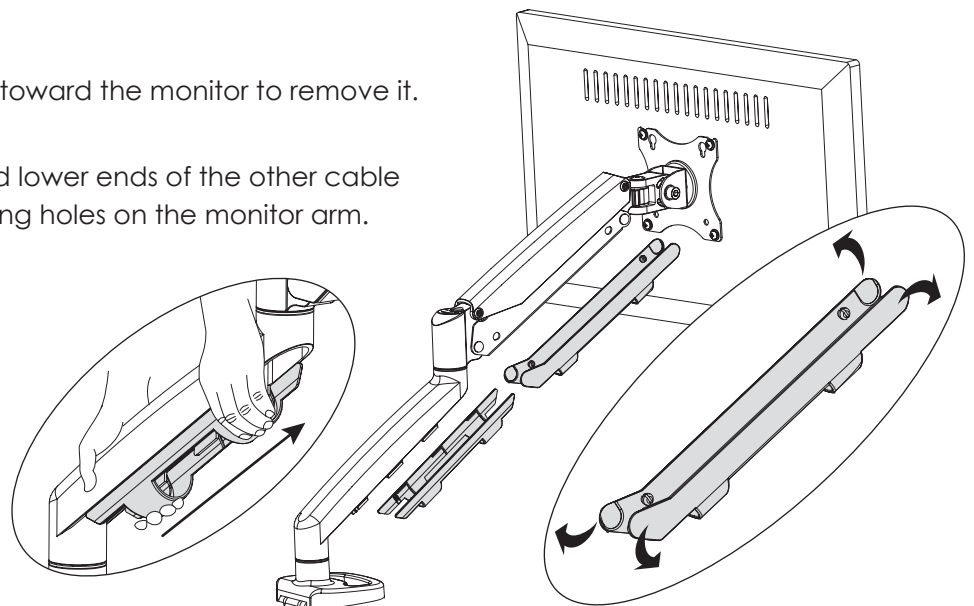

Install Cable Covers

- Install the upper cable cover with the monitor cable and power cord captured. Slightly pull apart the upper and lower ends of the cover to fit it over the mounting holes on the monitor arm.
- Then slide the lower cable cover onto the monitor arm with the cable and cord captured.

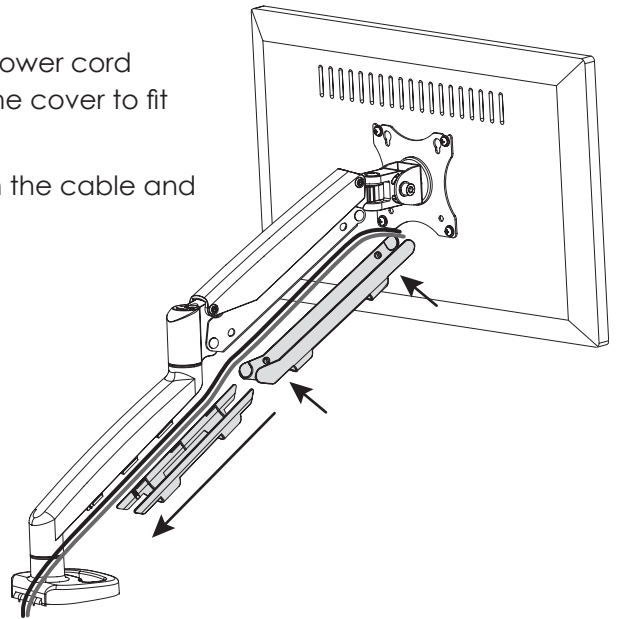

Monitor Arm Adjustments

There are two possible adjustments, both of which are made using the 6mm Allen key.

1. Monitor weight adjustment.

- If the monitor arm is difficult to raise or drifts lower, increase the weight adjustment. Turn the hex nut counterclockwise.
- If the monitor arm is difficult to lower or drifts higher, decrease the weight adjustment. Turn the hex nut clockwise.
- After completing the adjustment, the monitor arm should raise and lower easily, and maintain its position.

2. Monitor tilt adjustment.

- Loosen the nut to make tilting the monitor easier or tighten the nut to hold the tilt position more securely.

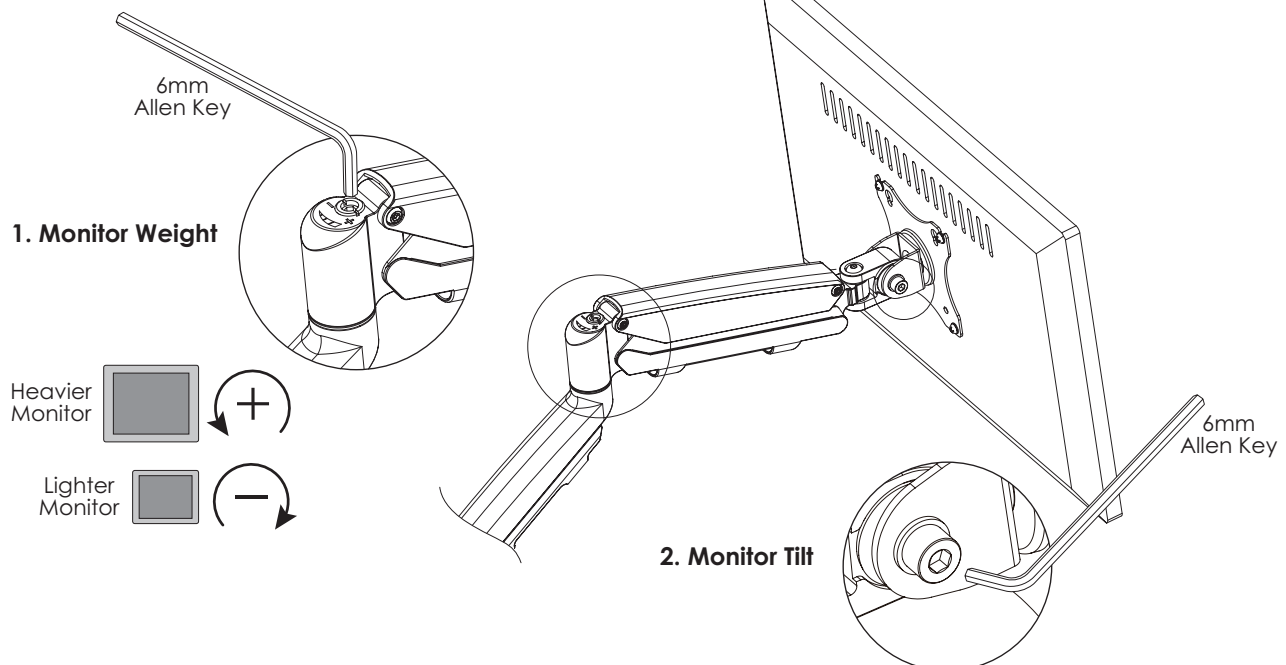

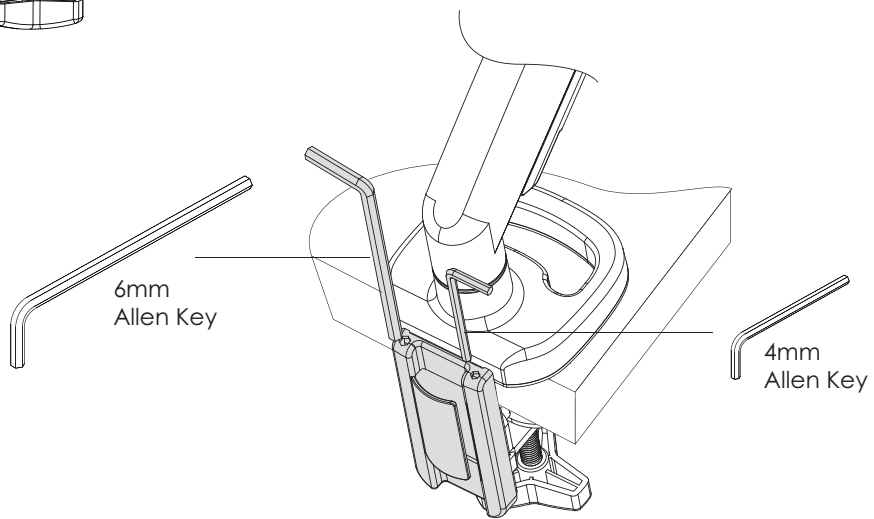
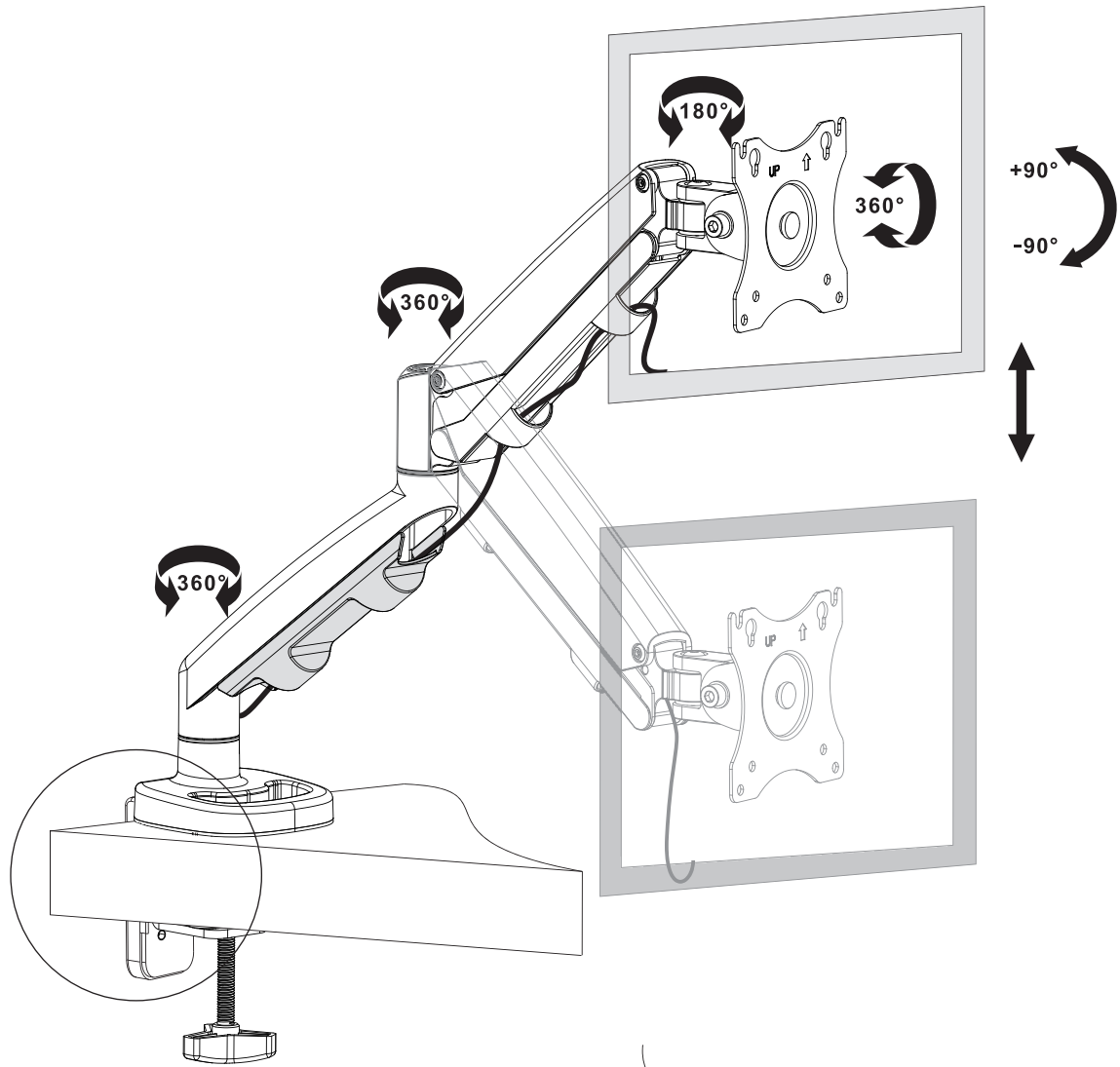



800.833.3746 | esiergo.com