

## LTH-EDGE

ADJUSTABLE LAPTOP TRAY

Model LTH-EDGE-SLV

LTH-EDGE Rev A 2/17

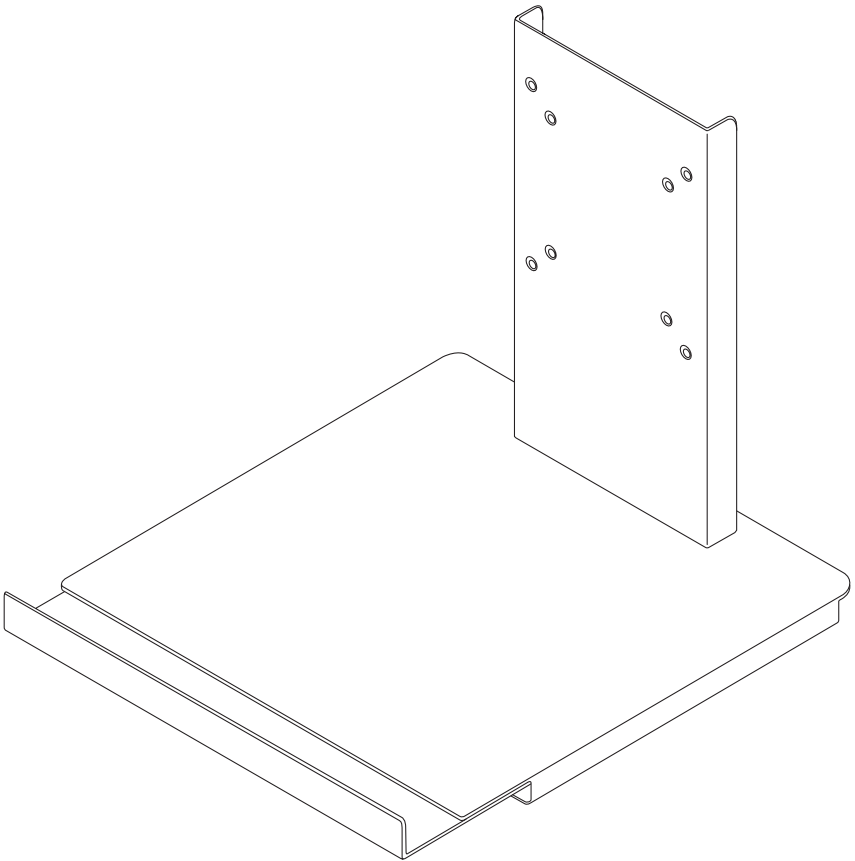



# INSTALLATION AND ADJUSTMENT

## LAPTOP TRAY INSTALLATION

**PLEASE REVIEW** these instructions before beginning the installation. Check that all parts shown below were provided with your order. Contact your supplier if any parts are missing. Do not discard the packaging until satisfied that the product operates to your satisfaction.

The LTH-EDGE adjustable laptop tray is used with an EDGE monitor arm. It is installed in place of a monitor. Refer to the instructions that came with the monitor arm for assembly and adjustment procedures for the EDGE system.

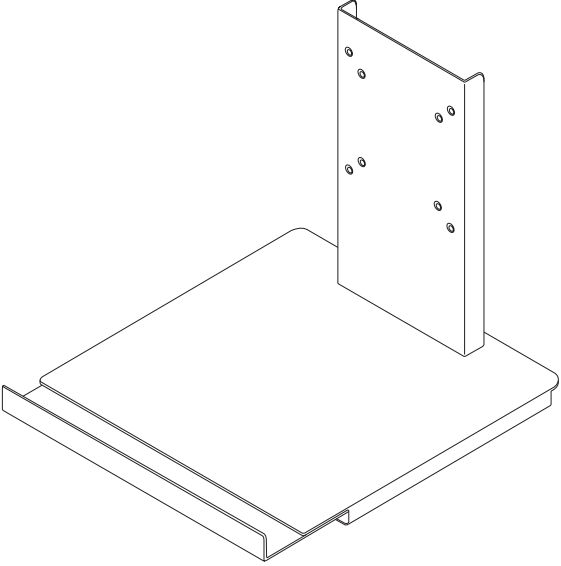
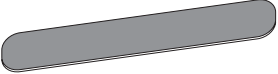
### PARTS PROVIDED

<p>Laptop Tray (1)</p> 	<p>Laptop Tray Nonskid Pad (2)</p>  <p>Laptop Tray Screw (4)</p>  <p><math>\frac{3}{8} \times \frac{1}{4}-32</math></p> <p>Laptop Tray Locking Nut (4)</p>  <p><math>\frac{1}{8} \times \frac{1}{4}-32</math></p>
--	--

**CAUTION:** Hand-tighten screws only. Do **not** use power tools.

### TOOLS REQUIRED

- Phillips screwdriver
- Pliers

## If the EDGE Monitor Arm Currently Has a Monitor Attached:

### Remove the Monitor

- Disconnect the monitor cables.
- If a VESA locking screw is installed, remove the screw.
- Press down on the plastic tab on the VESA mount to release the VESA plate.
- Lift the monitor and VESA plate from the VESA mount.

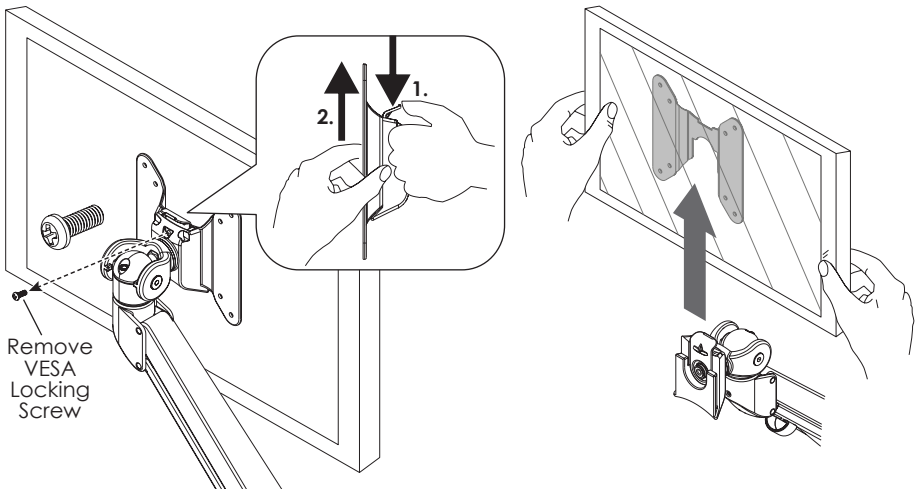

### Remove the VESA Plate from the Monitor

- Place the monitor face down on a flat surface.
- Remove the four screws that attach the VESA plate to the monitor.
- Remove the VESA plate.

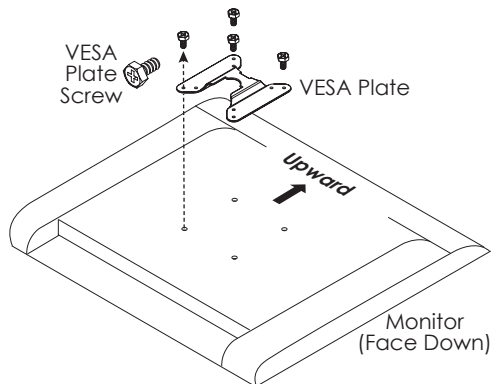

Proceed to "Attach the VESA Plate to the Laptop Tray" on page 4.

## LAPTOP TRAY INSTALLATION

### If No Monitor Is Attached to the EDGE Monitor Arm:

#### **Remove the VESA Plate from the VESA Mount**

- Press down on the plastic tab to release the lock.
- Pull the plate upward to remove.

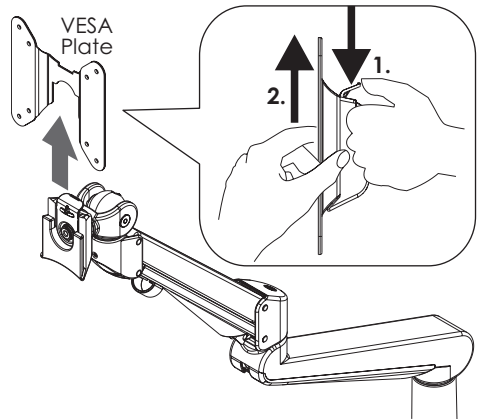

#### **Attach the VESA Plate to the Laptop Tray**

- Align the VESA plate holes with the holes on the back of the laptop tray. Attach the VESA plate using the four laptop tray screws and locknuts provided.
  - There are two sets of four holes on the VESA plate. One set has holes 3.9" (100mm) apart, the other set has holes 3" (75mm) apart. Either set of holes may be used.

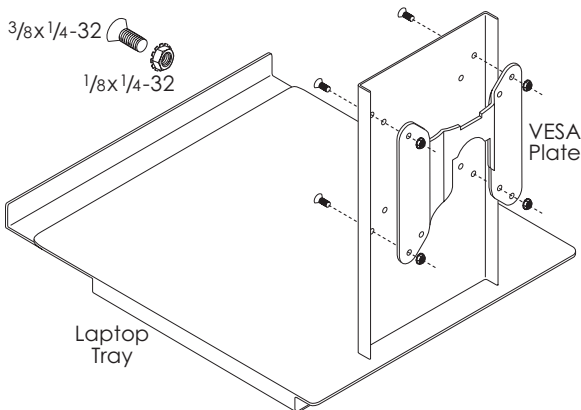

### Attach the Laptop Tray to the VESA Mount

- Slide the VESA plate and laptop tray onto the VESA mount. Make sure the VESA plate clicks securely in place.
  - **Optional:** Install a VESA locking screw behind the VESA plate to prevent the tab on the VESA mount from releasing the laptop tray.

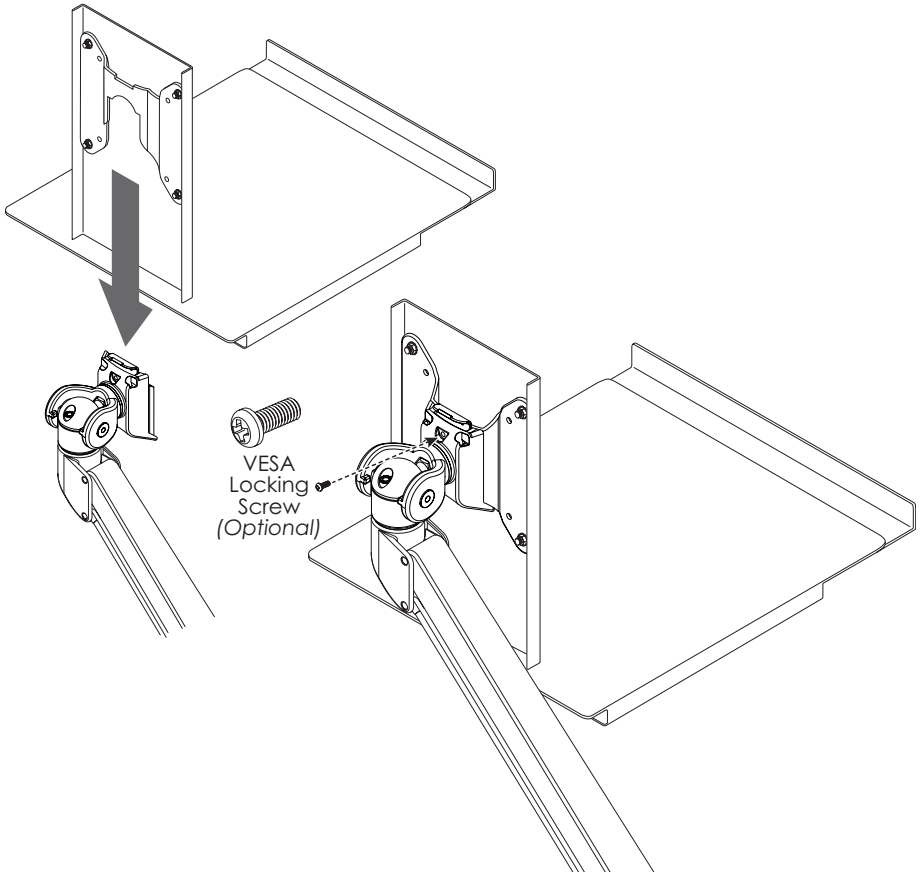

## LAPTOP TRAY INSTALLATION

### Laptop Tray Adjustment

- Loosen the two knobs on the underside of the laptop tray to adjust for the desired depth.
  - The laptop tray adjusts from 12" to 18¼" in depth to accommodate a laptop alone or a laptop with docking station.
- Apply the two nonskid pads to the tray surface to help secure the laptop.
  - Peel the adhesive packing from the pads and press them firmly in place.

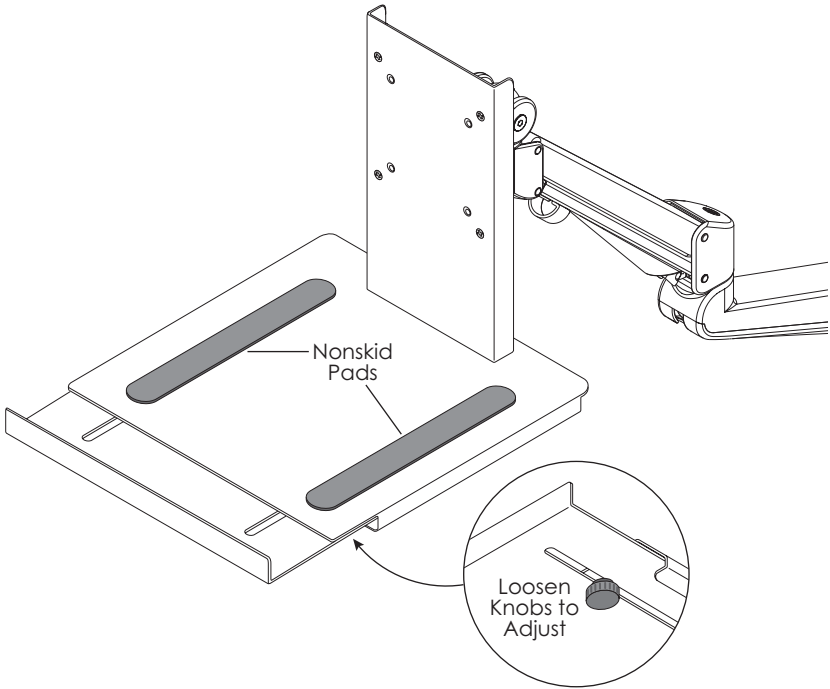





800.833.3746 | [esiergo.com](http://esiergo.com)