

## Solution All-Fit

ARTICULATING ARM and  
KEYBOARD PLATFORM

Model SOLUTION ALL-FIT

SOLUTION ALL-FIT Rev A 4/17

SOLUTION ALL-FIT









# INSTALLATION AND USE

## SOLUTION ALL-FIT

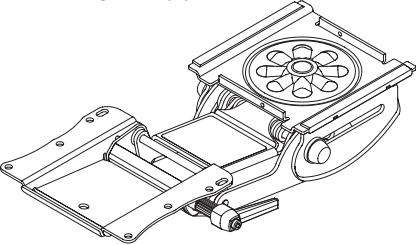
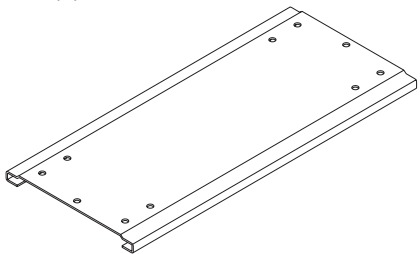
**PLEASE REVIEW** these instructions before beginning the installation. Check that all parts needed were provided with your order. Contact your supplier if any parts are missing. Do not discard the packaging until satisfied that the product operates to your satisfaction.

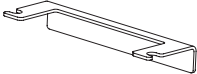
Solution 1 combines the AA100 articulating arm with the PL003-27N keyboard platform. In this instruction booklet, installation of the two products will be explained in sequence, beginning with the AA100.

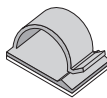
### AA100 PARTS PROVIDED

Articulating Arm (1) 	Track (1) 		
Front Stop (1) 	Track Extender (1) 	5/8" Wood Screws (20*)  *Includes Extras	Cord Clip (1) 
Rear Bumper* (1)  *Optional	<b>CAUTION:</b> This install requires a power drill. This is <b>not</b> a hand tool install. <b>ADDITIONAL TOOLS REQUIRED</b> <ul style="list-style-type: none"><li>• Drill with 1/8" bit</li><li>• #2 Phillips bit</li></ul>		

### STEP 1: Drill Pilot Holes for Attaching Track

- Position one end of the track 1/2" from the front edge of the work surface.
- Drill 1/8" pilot holes through the seven holes indicated in the illustration.  
— Drill the holes 5/8" deep.

**CAUTION:** Be careful not to drill through the top of the work surface.

With this short 13" track, the track extender is normally used as the rear stop. If the rear bumper will be used instead, drill a pilot hole in the center rear hole through the track into the bottom of the worksurface and do not drill pilot holes in the two rear side holes.

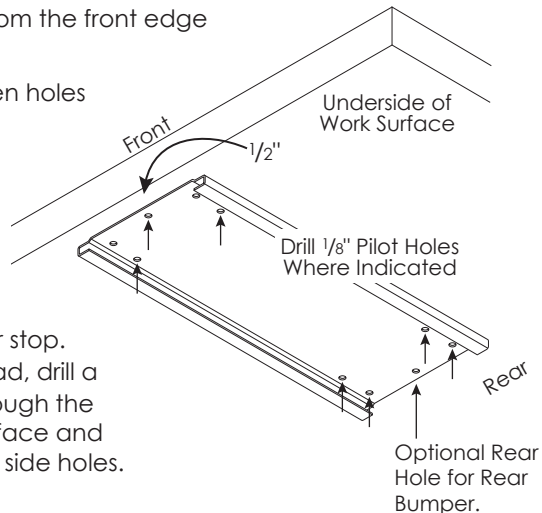

**STEP 2: Attach Track**

- First attach the track through the four center holes, as shown.
- Then attach the track extender through the two rear holes.
- Do not attach a screw through the front center hole at this time.

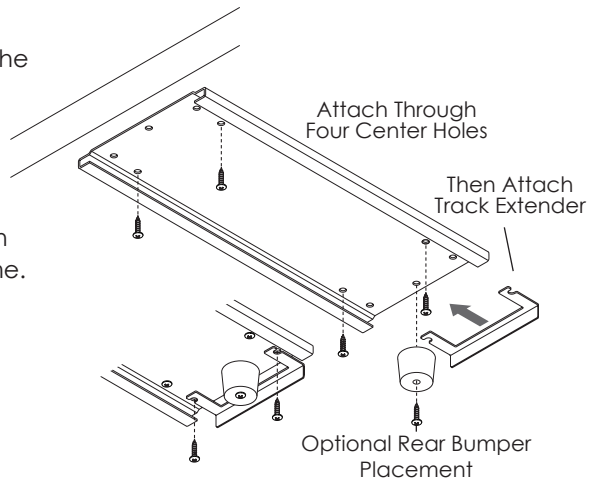
**STEP 3: Install Articulating Arm**

- Slide the articulating arm onto the track. Position it back far enough so that you have access to the front center hole on the track.

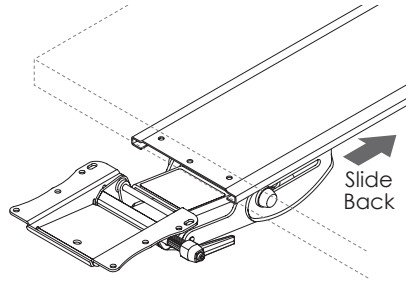
**STEP 4: Attach Front Stop**

- Position the front stop onto the front of the track and secure it with a screw through the center hole.
- Drill pilot holes for the two side screws and attach the ends of the front stop with two more screws.

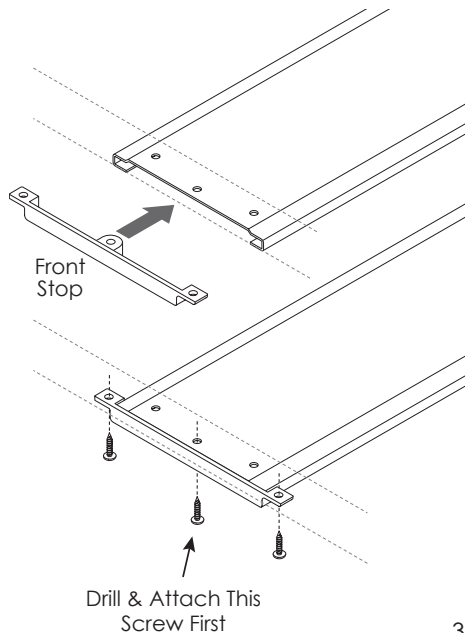

### **STEP 5: OPERATION**

#### **To Tilt:**

- Loosen the ratchet handle, adjust the tilt angle, then tighten the handle.

#### **To Telescope:**

- Lift the front of the platform and slide it inward to stow or outward to access.

#### **To Raise:**

- Grasp both sides of the platform and raise to the desired height.

#### **To Lower:**

- Grasp both sides of the platform, tilt up the front, and move down to the desired height.



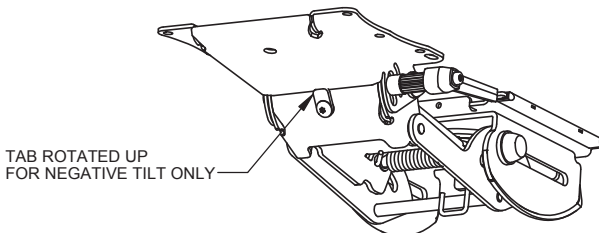
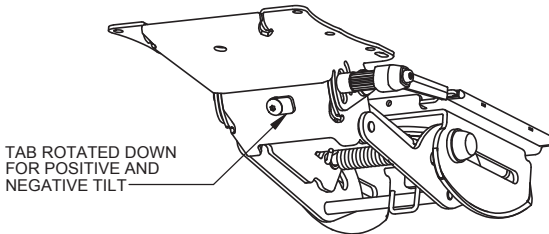

#### **To De-activate Positive Tilt Lock-out:**

- Rotate tab  $\frac{1}{4}$  turn to the right. Refer to diagrams below for further explanation:

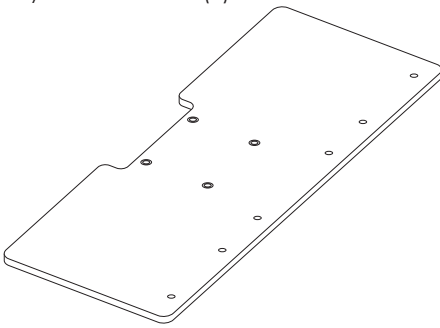
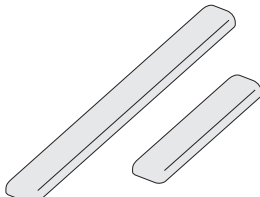

The keyboard platform for Solution All-Fit is PL003-27N (notched). Although the appearance varies, installation procedures are identical.

**PL003-25N PARTS PROVIDED**

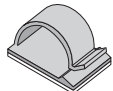
<p>Keyboard Platform (1)</p> 	<p>Palm Rest (1)</p>  <p>1 Each for Keying and Mousing</p>		
<p>Flathead Screw (4)</p>  <p>#8-32x1/2</p>	<p>Flange Nut (4)</p>  <p>#8x32</p>	<p>Panhead Screw (4)</p>  <p>#8-32x5/8 (R-Series: #8-32x3/4)</p>	<p>Cord Clips (2)</p> 

**CAUTION:** Hand-tighten screws only. Do **not** use power tools.

**ADDITIONAL TOOLS REQUIRED**

- Phillips screwdriver

**STEP 5: Attach Palm Rest(s)**

- Attach the palm rest(s) to the keyboard platform. Use the #8-32x5/8 panhead screws (#8-32x3/4 with the R-Series) and a Phillips screwdriver. Six screw holes are located in the keyboard platform to accommodate a variety of installation possibilities.
  - With one palm rest, attach it with two screws through the two end holes.
  - With two separate palm rests, attach each with two screws, as shown.
  - The mouse and keyboard palm rests may be attached on either the left or right sides of the keyboard platform.

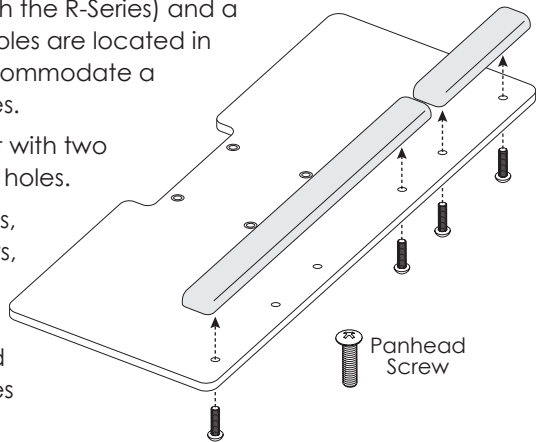

**STEP 6: Attach Keyboard Platform**

- Attach the keyboard platform to the keyboard arm and track assembly using the four flathead screws and flange nuts.
  - Be sure the flange on the nuts is facing upward.

**IMPORTANT:** The flange nuts must be fully tightened to ensure the nuts are locked. Use a Phillips screwdriver.

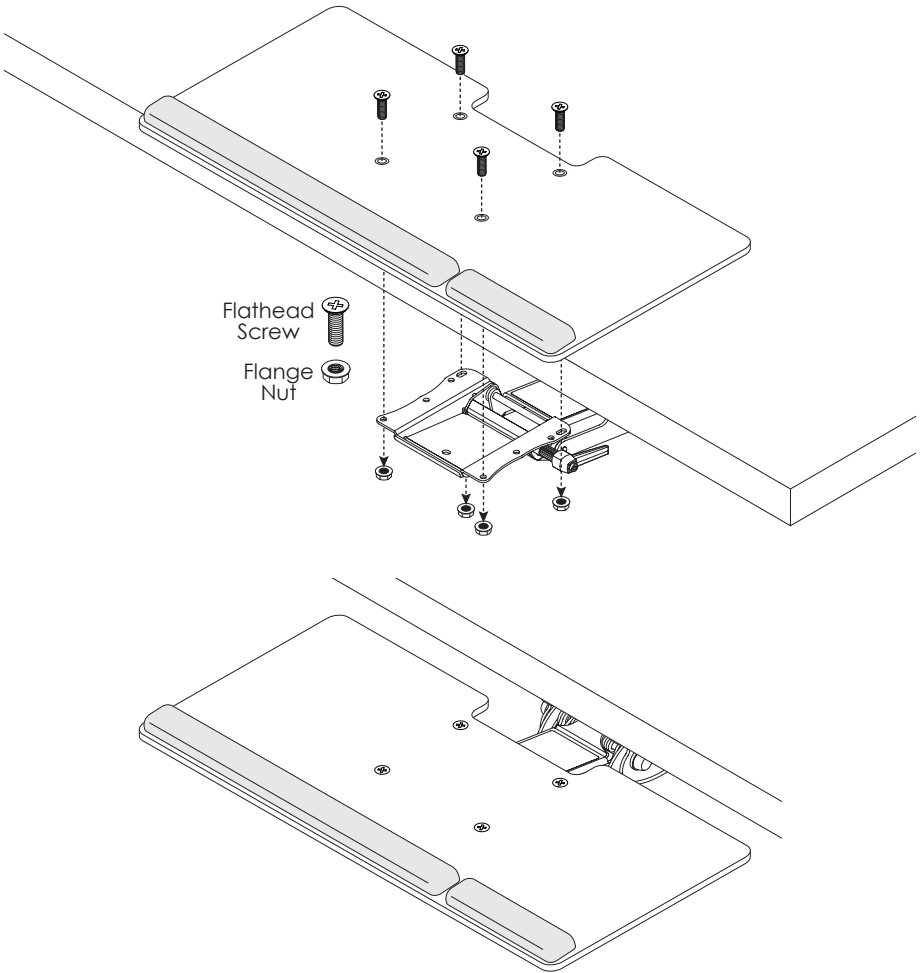

## **STEP 7: Manage Cables**

- Adhere cord clips to the underside of the keyboard platform as needed to organize the keyboard and mouse cables.

### **OPERATION**

#### **To Tilt:**

- Loosen the ratchet handle, adjust the tilt angle, then tighten the handle.

#### **To Telescope:**

- Lift the front of the platform and slide it inward to stow or outward to access.

#### **To Raise:**

- Grasp both sides of the platform and raise to the desired height.

#### **To Lower:**

- Grasp both sides of the platform, tilt up the front, and move down to the desired height.

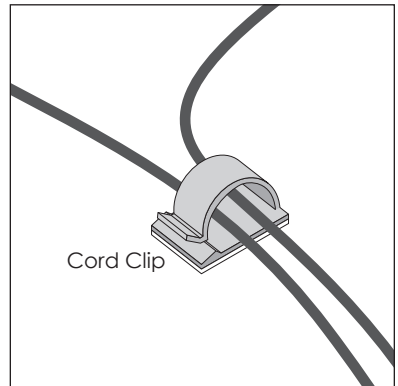

800.833.3746 | [esiergo.com](http://esiergo.com)