

Triumph-LX™

electric table base

Triumph-LX

electric table base



drawers easily slide over feet



locking casters

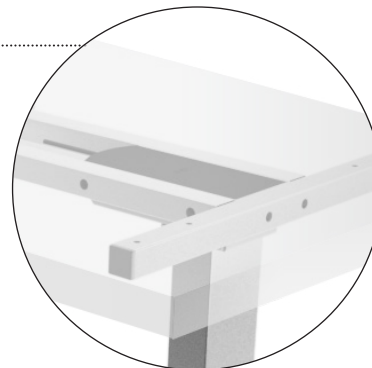

two motors

Product specs

- Electric height adjustment
- 220 lbs. base lifting capacity
- 1.4"/sec. adjustment speed
- 17.3" height adjustment range
 - 26.1"–43.4"(low/high)
(excluding worksurface)
- Two-stage adjustable table base
- Adjustable width frame
- Two motors
- Soft start
- Anti-collision safety feature
- Locking casters are available
- ADA compliant
- Steel frame and foot construction
- Low standby power consumption
- Exceeds BIFMA x5.5 requirements
- Warranty: 15 yrs. structural / 7 yrs. mechanical

Digital Keypad

- Digital programmable switch with three memory settings
- Keypad can slide under worksurface to store out of the way



esi

800.833.3746
esiergo.com

Triumph-LX

electric table base

Rectangle



Dimensions	Base model	Surface model
36"w x 24"d	2T-LX-C28-24-____	2R3624__
42"w x 24"d	2T-LX-C28-24-____	2R4224__
48"w x 24"d	2T-LX-C28-24-____	2R4824__
60"w x 24"d	2T-LX-C40-24-____	2R6024__
72"w x 24"d	2T-LX-C40-24-____	2R7224__
36"w x 30"d	2T-LX-C28-30-____	2R3630__
42"w x 30"d	2T-LX-C28-30-____	2R4230__
48"w x 30"d	2T-LX-C28-30-____	2R4830__
60"w x 30"d	2T-LX-C40-30-____	2R6030__
72"w x 30"d	2T-LX-C40-30-____	2R7230__

D-top



Dimensions	Base model	Surface model
60"w x 30"d	2T-LX-C40-30-____	D6030__
72"w x 30"d	2T-LX-C40-30-____	D7230__

Small equal corner



Dimensions	Base model	Surface model
42"wl x 42"wr x 24"d	2T-LX-C28-24-____	2EC424224__
48"wl x 48"wr x 24"d	2T-LX-C28-24-____	2EC484824__

Table bases can be purchased independently or combined with a worksurface. Worksurfaces can only be purchased with a table base. See laminate guide worksurface for details. ESI worksurfaces are made to exact dimensions. If nominal sizing is needed, please specify when ordering.

Caster Kit

- Set of caster wheels for table bases
- Increases height by 2.0"
- Locking wheels for security

MODEL # CASTERKIT-LX-2LEG

Available base finishes

- Silver -SLV
- Black -BLK
- White -WHT

Worksurface shapes - LT

Multiple worksurface shapes are available. See chart to the left for full list. Worksurfaces can be come in a variety of laminates.

Edge Detail

Worksurfaces ship with a standard square profile edge and coordinating 3mm edge band. Additional edge detail profiles are available.

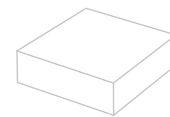

esi

800.833.3746
esiergo.com

Triumph-LX

electric table base

2T-LX-C28-24

adjustable width
30.8"–47.0"

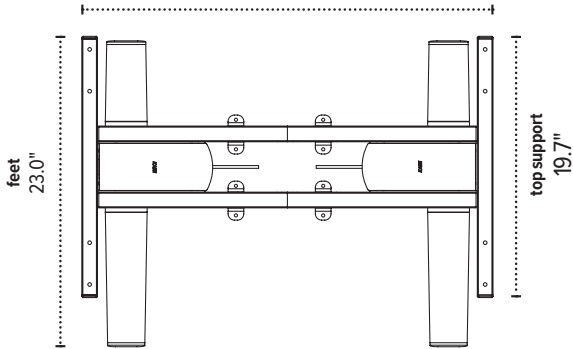

2T-LX-C40-24

adjustable width
42.7"–71.0"

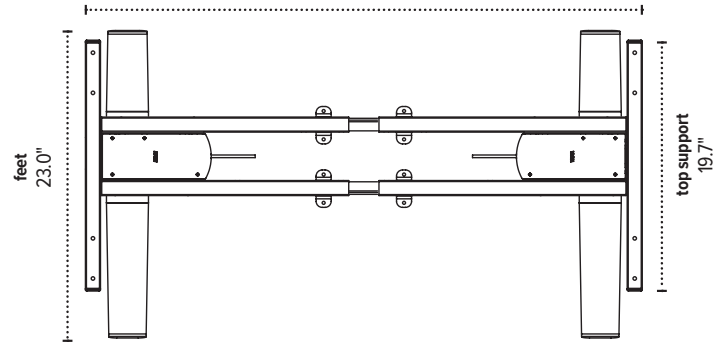

2T-LX-C28-30

adjustable width
30.8"–47.0"

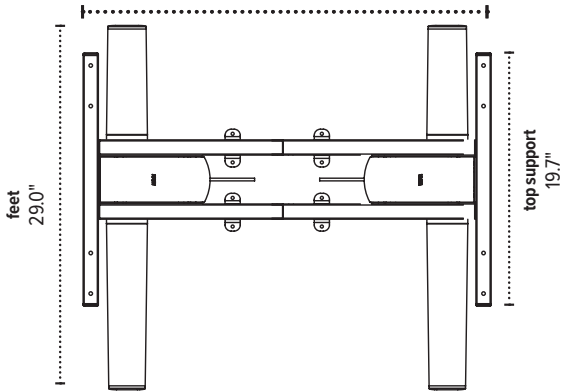

2T-LX-C40-30

adjustable width
42.7"–71.0"

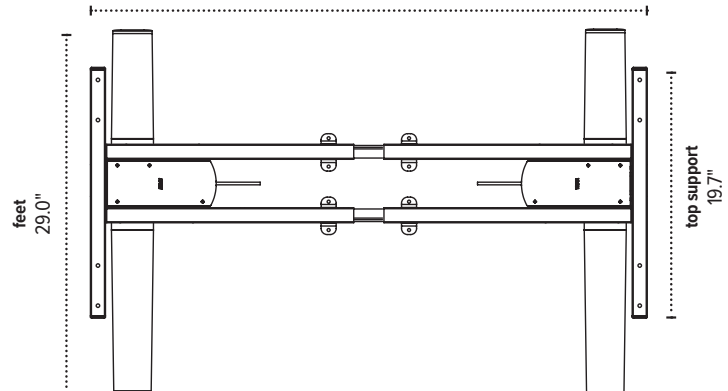

The base dimensions as shown are actual.

esi

800.833.3746
esiergo.com

© 2018 Fellowes, Inc.