



## Eagle Eye HGD-3000 User Manual



Concentrations of 4% with air can be explosive.  
Sparks or Hot surfaces can ignite them.

Should the concentration of hydrogen gas in the air surrounding the sensor reach 1% by volume, the "1% caution" yellow LED will light and the 1% internal relay will close. This relay should start an exhaust fan. Should the hydrogen concentration reach 2% by volume, the "2% warning" red LED will flash and an 80 db alarm will sound; the 1% relay will remain closed and the 2% signal relay will close. This relay closing activates an external alarm. Either relay can activate a remote exhaust fan and/or alarm.

### LOCATION

Hydrogen, colorless and odorless, is the lightest of all gases and thus rises. The detector, therefore, should be installed at the highest, draft-free location in the battery compartment or room where hydrogen gas would accumulate.

The size of the area one detector will protect depends upon the battery compartment or room. The detector measures the hydrogen gas in the air immediately surrounding the sensor. If hydrogen gas might accumulate in several, unconnected areas in the compartment or room, individual detectors should be placed at each location

**Optional Accessories:** Steel Junction box for mounting on wall or ceiling; breakout box for easy access control; NFPA 2 compliant fan.

**Added Benefits: Insurance. Installation of a detector in areas where batteries are charged may result in a premium reduction**

### FEATURES

- Automatic Operation
- Continuous Monitoring
- High Sensitivity and Stability
- Solid State Reliability Simple Installation
- Two Year Warranty

### SPECIFICATIONS

Dimensions:

- Height 7 inches (17.8 cm.)
- Width 4-¾ inches (12.0 cm.)
- Depth 2-½ inches (5.5 cm.)

Mounting:

- Four 3/16 inch (4.5 mm.) screws

Power Requirements:

- AC: 80-250 VAC
- 50/60 Hz
- DC: 18-60 VDC

### SENSOR

The sensor consists of a semiconductor whose electrical conductivity increases when hydrogen is absorbed on its surface. Conductivity, proportional to the gas concentration, is continuously measured by an electronic circuit.

AC Version: 90-250 VAC 50/60 Hz

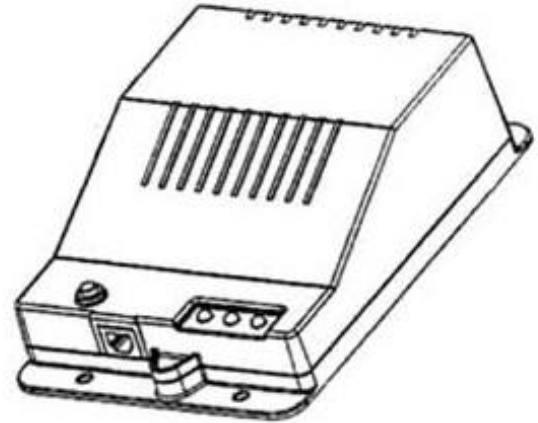
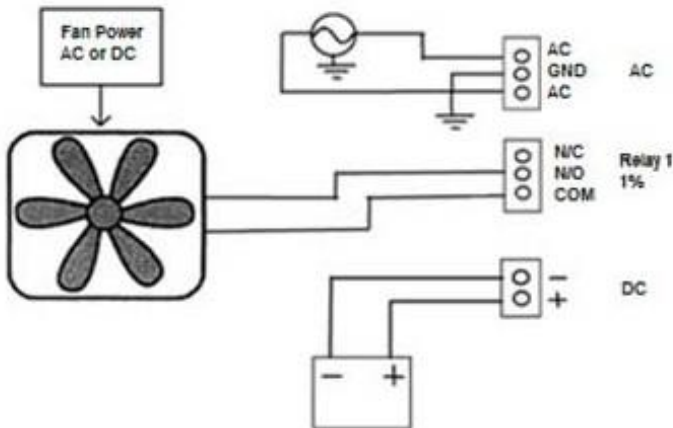

DC Version: 18-60 VDC

1. The detector has an internal, normally-open Form C relay that closes if the sensor detects a 1% concentration of hydrogen gas in the air surrounding it.
2. The detector's internal fan relay is rated at: 10 amps at 250 volts ac 1/3 horsepower at 125 volts ac 1/3 horsepower at 250 volts dc
3. For currents higher than these relay ratings, add an external relay.
4. Connect the wires from the fan relay in "series" with the live wire (black) of the ac input line to the exhaust fan and/or alarm.

#### Directly Switched AC Fan Installation

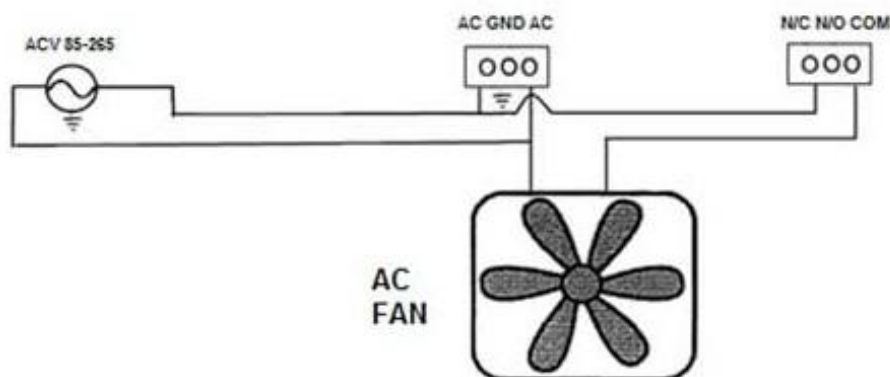



## Installation

Hydrogen is only 7% the density of air, and thus rises. Your hydrogen gas detector, therefore, should be installed at the highest, draft-free location in the battery room or battery compartment where hydrogen gas would accumulate.

Attach the detector to the wall, ceiling, or junction box using the mounting holes at the top and bottom of the detector box.

The detector box will fit the following junction boxes: Appleton 2G5075, Bowers 702 SPL, Raco 951 or Steel City 2G-1/2&3/4. If you have difficulty finding one of these junction boxes, you can order one from your dealer.

Remove the cover from the detector box using care not to break the hinge connection at the top of the box.

The detector has a terminal block for connections to the power source, and to an internal power relay that can switch a remote exhaust fan and/or external alarm on and off.

For power input, use an 18 gage SJT 3-connector PVC jacketed cable (Belden 19348, equivalent or better). For relay wires, use 14 gage twisted-pair wire (Belden 8473, equivalent or better).

The detector's relay dry contacts are rated at 10A/250VAC sufficient for most 1/3 HP exhaust fans. For higher current requirements, add external relays.

Ensure that your installation complies completely with all relevant local, state, federal and OSHA safety and health regulations.

See over for remote panel (breakout box) connection.

## Operation

Keep the detector on at all times. If the green LED is lit, power is on.

When power is first turned on, approximately 3 minutes will elapse before the detector will start to function. This delay is to prevent false activation of the internal relay and alarm.

If the unit has been stored unenergized for more than one week, the sensor will require about an hour to stabilize. During this period the sensor will be overly sensitive to hydrogen gas. This may activate the internal relay at a slightly lower concentration level, but normally should not reach the point of activating the internal alarm.

If the concentration of hydrogen gas in the air surrounding the sensor reaches 1% by volume, the yellow LED will light and the 1% internal relay will close to activate a remote fan and/or alarm. A 4 second delay prevents false activation.

Should the concentration reach 2%, the red LED will flash, the internal 80 db warning alarm will sound, and the 2% signal relay will close. The 1% relay will remain closed and the yellow LED on.

When the concentration decreases below 2%, the red LED will turn off, the internal alarm will stop, and the 2% signal relay will open. When it falls below 1% the 1% relay will open after a 30 second delay.

The sensor is calibrated at room temperature and humidity at sea level. It is slightly more sensitive at higher temperature, humidity or altitude. In these situations, the detector may activate at a slightly lower gas concentration. This should not noticeably effect its operation nor require any adjustment.

Note: the sensor detects several other gases in addition to hydrogen. Its sensitivity to other gases, however, is much lower than its sensitivity to hydrogen. Although additive, the presence of other gases is unlikely to falsely activate the detector.

## Calibration

This detector has been calibrated at the factory for hydrogen gas and should not be adjusted in the field. DO NOT ATTEMPT TO FIELD CALIBRATE THIS UNIT.

## Testing (after the power is on for 10 minutes)

A "push-to-test" button is located on the unit's front. Push and hold this button for approximately 2 seconds to test the unit's electronic circuitry. The caution and warning LEDs will light in sequence; the 1% and 2% relays will activate whatever is connected to them and the internal warning alarm will sound. The "push-to-test" button does NOT test the sensor itself.

Unless the detector becomes overly sensitive, recalibration or replacement of the sensor board (the small vertical board) should not be necessary for several years. For safety sake, however, replace the sensor board every five years.

## Warning

This detector is added protection, not a substitute for prudent safety measures where hydrogen gas is present. For large or highly sensitive areas, use two or more detectors.



The HGD-3000 is designed for remote locations and includes additional sensors: A photoelectric smoke detector, an IR intrusion alarm (HGD-3000i model only), thermostat, and a power monitor. Alarms are reported by dry contact, they are normally open and close on alarm, except for the power supervisor contact which is normally closed and opens on loss of power. The thermostat alarm activates the 1% relay (to start a fan) at 104 °F with +/- 5 °F adjustable range.

