

BC-2500 SWITCH MODE UTILITY CHARGER, 8 SLOT CHASSIS FLOOR MOUNTING INSTALLATION INSTRUCTION

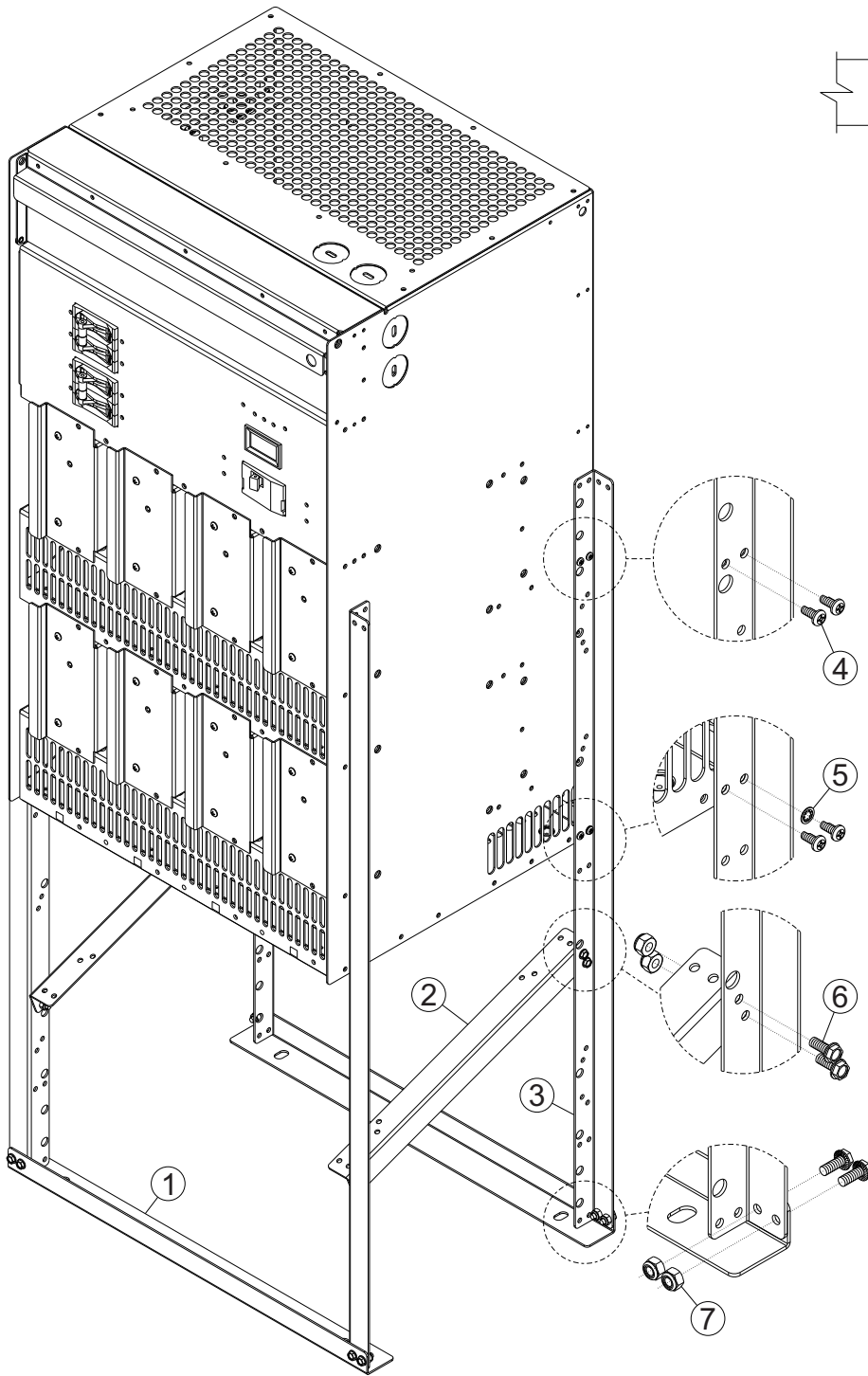

8 SLOT CHASSIS FLOOR MOUNTING PATTERN

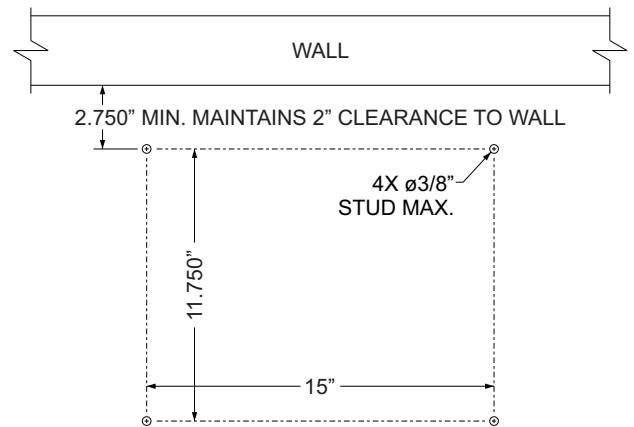

Recommended Procedure

1. Remove charger supplied rack mounting or pallet mounting brackets if present.
2. Using two people, place charger on its back side.
3. Attach item #3, leg brackets (4 per charger assembly) as shown using supplied hardware, item # 4, #8 screws (4 per leg). Use one #8 washer, item #5 (on 1 screw per leg). Torque to 18 in-lbs.
4. Attach item #1, base bracket, to ends of legs as shown using hardware items #6, #10 screw & #7 #10 lock nut (2 each per leg). Torque to 22 in-lbs.
5. Attach item #2, brace bracket, in-between front and back legs as shown using hardware items #6, #10 screw & #7 #10 lock nut (4 each per brace). Torque to 22 in-lbs.
6. Using two people, place charger back upright on the desired mounting surface. Use the "floor mounting pattern provided at top & user supplied hardware, torque appropriately.

ITEM NO.	ITEM DESCRIPTION	QTY. / ASSY.
①	BRACKET, BASE	2
②	BRACKET, BRACE / EXTENSION	2
③	BRACKET, LEG	4
④	SCREW, #8-32 X .375, SELF TAPPING, PANHEAD	16
⑤	WASHER, #8, LOCK, STAR	4
⑥	SCREW, #10-32 X .250, HEX HEAD	16
⑦	NUT, #10-32, LOCKING	16



BC-2500 SWITCH MODE UTILITY CHARGER, 4 SLOT CHASSIS FLOOR MOUNTING INSTALLATION INSTRUCTION

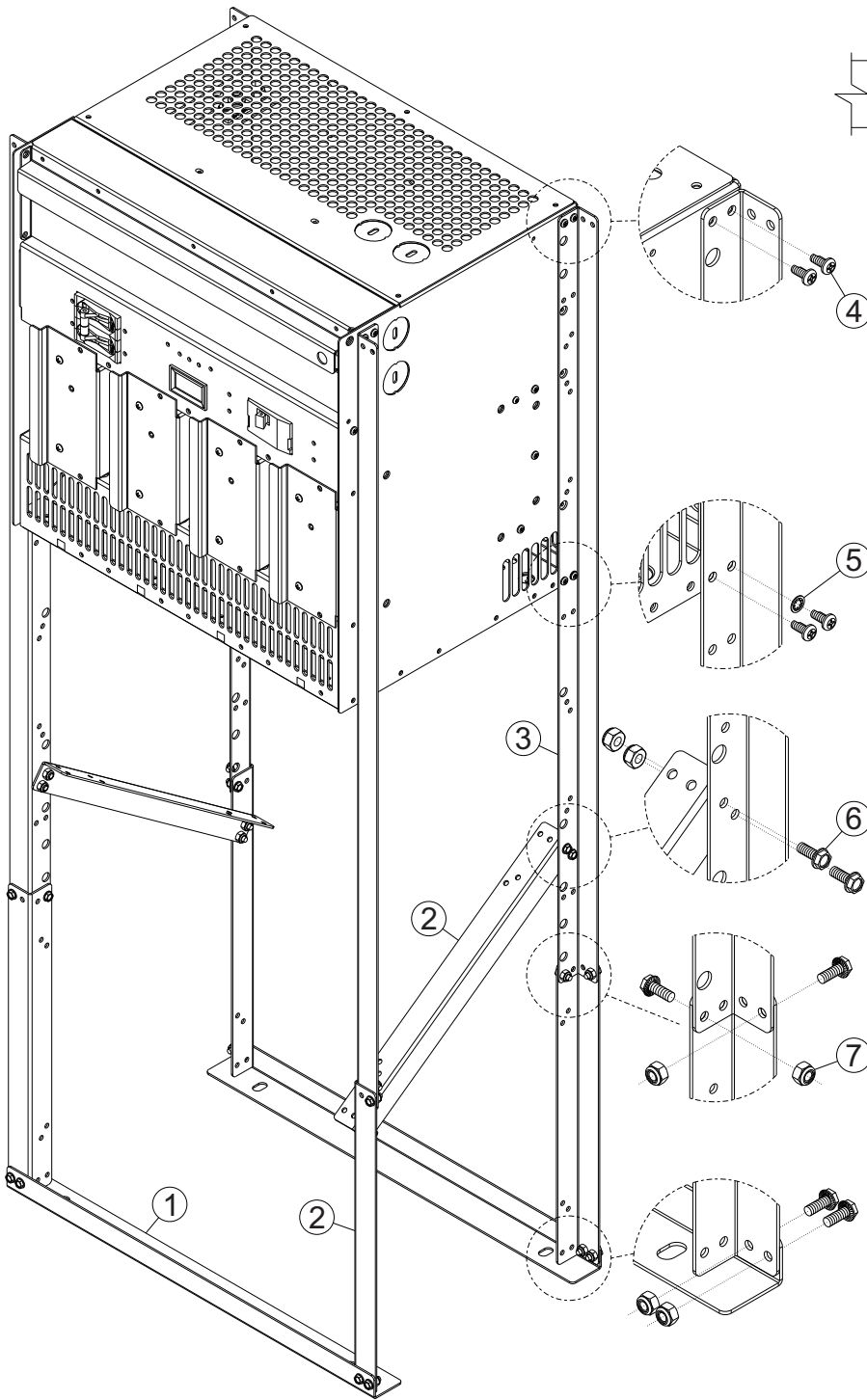

4 SLOT CHASSIS FLOOR MOUNTING PATTERN

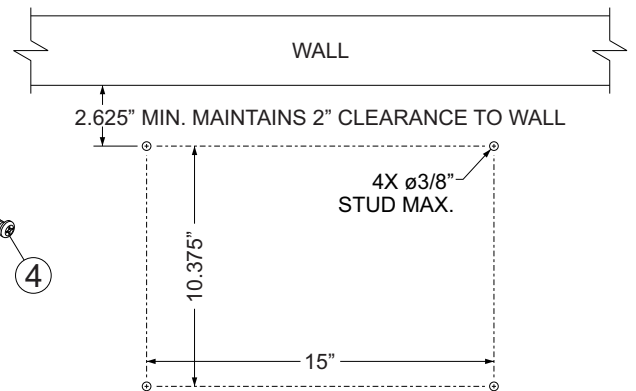

Recommended Procedure

1. Remove charger supplied rack mounting or pallet mounting brackets if present.
2. Using two people, place charger on its back side.
3. Attach item #3, leg brackets (4 per charger assembly) as shown using supplied hardware, item # 4, #8 screws (4 per leg). Use one #8 washer, item #5 (on 1 screw per leg). Torque to 18 in-lbs.
4. Attach item #2, extension bracket, to ends of legs as shown (1 per leg) using hardware items #6, #10 screw & #7 #10 lock nut (2 each per leg). Torque to 22 in-lbs.
5. Attach item #1, base bracket, to ends of legs as shown using hardware items #6, #10 screw & #7 #10 lock nut (2 each per leg). Torque to 22 in-lbs.
6. Attach item #2, brace bracket, in-between front and back legs as shown using hardware items #6, #10 screw & #7 #10 lock nut (4 each per brace). Torque to 22 in-lbs.
7. Using two people, place charger back upright on the desired mounting surface. Use the "floor mounting pattern provided at top & user supplied hardware, torque appropriately.

ITEM NO.	ITEM DESCRIPTION	QTY. / ASSY.
①	BRACKET, BASE	2
②	BRACKET, BRACE / EXTENSION	6
③	BRACKET, LEG	4
④	SCREW, #8-32 X .375, SELF TAPPING, PANHEAD	16
⑤	WASHER, #8, LOCK, STAR	4
⑥	SCREW, #10-32 X .250, HEX HEAD	24
⑦	NUT, #10-32, LOCKING	24