

Eagle Eye GD-3000

User Manual

Updated 10/09/13



4031 W Kiehnau Ave
Milwaukee, WI 53209
TEL:1-414-962-3377
TOLL FREE: 1-877-805-3377
FAX:1-414-962-3660
www.eepowersolutions.com

Table of Contents

| | |
|--|-----------|
| 1.1 Intended Use | 3 |
| 1.2 List of Warnings and Cautions within these User Instructions | 3 |
| 2. USE INSTRUCTIONS AND LIMITATIONS | 4 |
| 2.1 Use For | 4 |
| 2.2 Do Not Use For | 5 |
| 2.3 General Description | 5 |
| 2.4 Specifications..... | 6 |
| 3. INSTALLATION AND OPERATING INSTRUCTIONS | 6 |
| 3.1 General Information | 7 |
| 3.2 Location | 7 |
| 3.3 Installation | 7 |
| 3.4 Power Up | 11 |
| 3.5 Operation | 12 |
| 3.6 Default Configuration – Factory Settings | 12 |
| 3.7 Onboard Diagnostics | 15 |
| 3.8 Sensor Poisons | 16 |
| 4. MAINTENANCE | 16 |
| 4.1 Cleaning..... | 16 |
| 4.2 Testing | 16 |
| 4.2.1 Operation Test | 17 |
| 4.2.2 Manual Operation Test | 17 |
| 4.2.3 Combustible Gas Test | 18 |
| 4.2.4 Quick Gas Test | 21 |
| 4.3 Field Calibration Procedure..... | 22 |
| 4.3.1 Zero the Sensor | 22 |
| 4.3.2 Calibration..... | 22 |
| 5. EAGLE EYE FIXED GAS DETECTION PRODUCTS LIMITED | |
| WARRANTY | 23 |
| 6. CONTACT EAGLE EYE POWER SOLUTIONS | 24 |

1. GENERAL SAFETY INFORMATION

1.1 Intended Use

The Eagle Eye GD-3000 Combustible Gas Detector, Controller, and Transducer is a low voltage device with selectable 4-20mA output, buzzer and digital display options. It is an electronic detection system used to measure the concentration of combustible gas and provide feedback and automatic exhaust fan control to help reduce combustible gas concentrations in parking garages, maintenance facilities or other light commercial applications. The Eagle Eye GD-3000 Combustible Gas Detector is a low level meter capable of displaying from 0-50% LEL (Lower Explosive Limit) of combustible gas. The Eagle Eye GD-3000 Combustible Gas Detector is factory calibrated and tested for proper operation, but can also be calibrated in the field.

1.2 List of Warnings and Cautions within these User Instructions

WARNING

- Each person using this equipment must read and understand the information in these *User Instructions* before use. Use of this equipment by untrained or unqualified persons, or use that is not in accordance with these *User Instructions*, may adversely affect product performance and **result in sickness or death**.
- Use only for monitoring the gas which the sensor and instrument are designed to monitor. Failure to do so may result in exposures to gases not detectable and **cause sickness or death**.
- GD-3000 may not function effectively below 0°F or above 125°F (-18°C or above 52°C). Using the detector outside of this temperature range may adversely affect product performance and **result in sickness or death**.
- This detector helps monitor for the presence and concentration level of certain specified airborne gases. Misuse may produce an inaccurate reading, which means that higher levels of the gas being monitored may be present and could result in overexposure and **cause sickness or death**.
- Each time the unit is turned on it performs a self-test, which activates visual alarms. If the self-test fails, or if all the alarms do not activate, do not use. Failure to do so may adversely affect product performance and **result in sickness or death**.
- Do not cover or obstruct visual alarm. Doing so may adversely affect product performance and **result in sickness or death**.

- Do not disassemble unit or attempt to repair or modify any component of this instrument. This instrument contains no user serviceable parts, and substitution of components may impair product performance and **result in sickness or death.**
- Using a certified gas with a concentration other than the one listed for this instrument and sensor when conducting a calibration or calibration verification test (bump test) will produce inaccurate readings. This means that higher levels of the gas being monitored may be present and could result in overexposure and **cause sickness or death.**
- The following steps must be performed when conducting a calibration or calibration verification test (bump test) to ensure proper performance of the monitor. Failure to do so may adversely affect product performance and **result in sickness or death.**
- When performing a calibration or calibration verification test (bump test) only use certified calibration gas at the required concentration level. Do not calibrate with expired calibration gas.
- If the instrument cannot be calibrated, do not use until the reason can be determined and corrected.
- Do not cover or obstruct display or visual alarm cover.
- Ensure sensor inlet is unobstructed and is free of debris.

2. USE INSTRUCTIONS AND LIMITATIONS

WARNING

Each person using this equipment must read and understand the information in these *User Instructions* before use. Use of this equipment by untrained or unqualified persons, or use that is not in accordance with these *User Instructions*, may adversely affect product performance and **result in sickness or death.**

2.1 Use For

The Eagle Eye GD-3000 Combustible Gas Detector helps combustible gas detection and automatic exhaust fan control for automotive maintenance facilities, enclosed parking garages, warehouses with forklifts, etc. The Eagle Eye GD-3000 can be used with 12VDC or 24VDC N.O. (fire/security) panels.

WARNING

Use only for monitoring the gas which the sensor and instrument are designed to monitor. Failure to do so may result in exposures to gases not detectable and **cause sickness or death.**

2.2 Do Not Use For

The Eagle Eye GD-3000 Combustible Gas Detector is **NOT** intended for use in hazardous locations or industrial applications such as refineries, chemical plants, etc. **DO NOT** mount the Eagle Eye GD-3000 Combustible Gas Detector where the normal ambient temperature is below 0°F or exceeds 125°F (-18°C or above 52°C). The GD-3000 Combustible Gas Detector mounts on a type 4S electrical box supplied by the contractor.

WARNING

The Eagle Eye GD-3000 Combustible Gas Detector may not function effectively below 0°F or above 125°F (-18°C or above 52°C). Using the detector outside of this temperature range may adversely affect product performance and **result in sickness or death.**

2.3 General Description

The Eagle Eye GD-3000 Combustible Gas Detector is a low voltage, dual relay combustible gas (EX) detector and automatic ventilation controller. The GD-3000 Combustible Gas Detector uses a microcomputer controlled, electronic system to measure the concentration of combustible gas, actuate relays and provide a 4-20mA (0-50% LEL) output. The GD-3000 Combustible Gas Detector is low maintenance with a long life (5+ years) pellistor sensor and optional gas test and calibration kits. The GD-3000 Combustible Gas Detector is a low level meter capable of displaying from 0-50% LEL of combustible gas.

Features

- ETL Listed to UL 61010-1
- The Eagle Eye GD-3000 Combustible Gas Detector can be bump-tested with the FTK with 10% LEL Methane, 10% LEL Propane or 10% LEL Hydrogen gas, regulator and calibration hood.
- The GD-3000 Combustible Gas Detector can be field calibrated using 10% LEL Methane, 10% LEL Propane or 10% LEL Hydrogen gas, regulator and calibration hood.
- The GD-3000 Combustible Gas Detector is a low level meter capable of displaying from 0-50% LEL EX
- Selectable fan and alarm relay activation
- 5A SPDT fan relay controls starters of exhaust fans
- 0.5A N.O. or N.C. alarm relay connects to warning devices or control panels
- 4-20mA current loop

- The GD-3000 Combustible Gas Detector mounts on a standard 4x4 electrical box and becomes cover for the box
- Supervised system: any internal detector problem will cause the fan & alarm relay to activate
- Optional calibration kit is available. One screw allows access for calibration

2.4 Specifications

- Power: 3W (max) from 12 to 24VAC (Volts Alternating Current) or 12 to 48VDC (Volts Direct Current)
- Current @ 24VDC: 75mA in alarm (two relays), 50mA (fan relay only)
- Shipping Weight: 1 pound (0.45 kg)
- Size: 4 1/2 x 4 x 2 1/8 in. (11.4 x 10.2 x 5.4 cm)
- Color: dark gray
- Connections: plugs/terminals
- Mounting box: (not included) 4x4 electric
- Fan relay: 5A, 240VAC, pilot duty, SPDT
- Fan relay actuation: selectable at 1, 2, 3, 4, 5, 6, 7, 8, 9, 10 (default), 11, 12, 13, 14, 15, 16, 17, 18, 19, 20% LEL
- Fan Delay Settings of 0, 1, 3 (default), 5 and 10 minutes
- Fan Minimum Run Time settings are OFF (default), 3, 5, 10 or 15 minutes
- Alarm relay: 0.5A 200V, 10VA
- Alarm relay actuation: selectable N.O. default or N.C.
- Alarm relay settings: OFF, 5, 10, 15, 20 (default), 25% LEL
- Current loop, 4-20mA for 0-50% LEL
- Operating environ: 0°F to 125°F (-18°C to 52°C). 10 to 90% RH

3. INSTALLATION AND OPERATING INSTRUCTIONS

The following instructions are intended to serve as a guideline for the use of the Eagle Eye GD-3000 Combustible Gas Detector, Controller and Transducer. It is not to be considered all-inclusive, nor is it intended to replace the policy and procedures for each facility.

WARNING

This detector monitors for the presence and concentration level of certain specified airborne gases. Misuse may produce an inaccurate reading, which means that higher

levels of the gas being monitored may be present and could result in overexposure and **cause sickness or death.**

If you have any doubts about the applicability of the equipment to your job situation, consult an Industrial Hygienist.

3.1 General Information

The Eagle Eye GD-3000 Combustible Gas Detector helps combustible gas detection and automatic exhaust fan control for automotive maintenance facilities, enclosed parking garages, warehouses with forklifts, etc. The GD-3000 can be used with 12VDC or 24VDC N.O. (fire/security) panels.

3.2 Location

The Eagle Eye GD-3000 Combustible Gas Detector is usually located in areas where there is potential for gas leaks; where there are gas appliances, areas through which gas pipes pass, where batteries are being stored or charged, etc. **DO NOT** mount the GD-3000 Combustible Gas Detector in a corner. **DO NOT** mount the GD-3000 Combustible Gas Detector where the normal ambient temperature is below below 0°F or exceeds 125°F (-18°C or above 52°C). If the target gas is lighter than air; natural gas (Methane) or Hydrogen (H₂), mount the GD-3000 Combustible Gas Detector high on a wall about one foot down from the ceiling. If the target gas is heavier than air; propane (LP), mount the GD-3000 Combustible Gas Detector on a wall or column one foot above the floor. Use the same spacing as for smoke detectors-30 foot centers, 900 square feet per detector.

Note: alcohols, ammonia, cleaning solvents, paint thinner; gasoline vapors and aerosol propellants (aerosol cans such as hair spray usually contain a combustible gas) may cause alarms.

3.3 Installation

1. The Eagle Eye GD-3000 Combustible Gas Detector mounts on a type 4S electrical box supplied by the contractor.

2. Connect the Eagle Eye GD-3000 Combustible Gas Detector to Class 2 power supply only. It is suggested to use a separate transformer for powering the unit or units because of possible interferences from other devices on the same power supply.

3. Connect the Eagle Eye GD-3000 Combustible Gas Detector to the control cables with terminal plugs. When making connections, make sure the power is off.

Typical installation in small garage

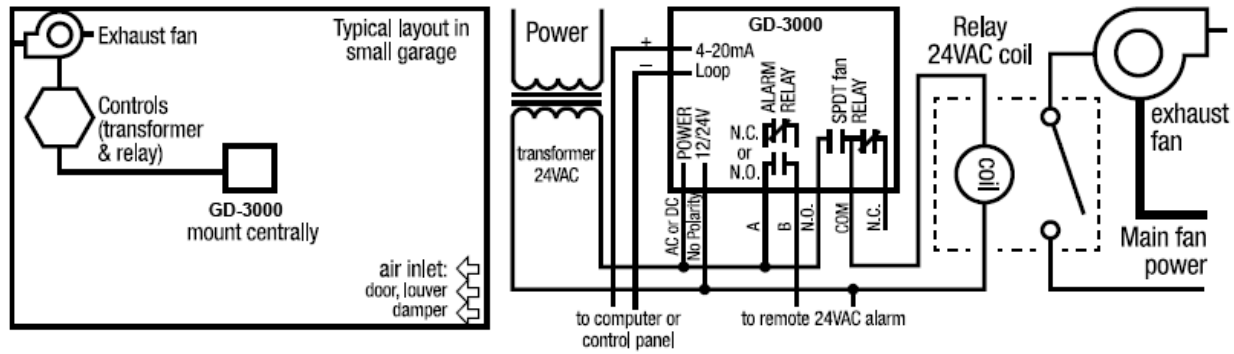

4. There are two terminals for Power: 12 to 24VAC or 12 to 48VDC, with no polarity preference.

5. There are two terminals for the dry alarm relay contacts, again with no polarity preference. The alarm relay can switch up to 0.5A, 200V, or 10VA. The alarm relay is activated if gas reaches or exceeds the alarm settings.

6. The alarm relay can be configured to normally open (default) (N.O.) or normally closed (N.C.) and will activate if the gas concentration exceeds alarm set point (5, 10, 15, 20 (default), 25% LEL). It will deactivate once the gas concentration drops below the alarm set point. Note that the “disable” setting will cause the alarm relay not to engage at all.

7. The dry contact, SPDT fan relay has three terminals. The common (COM.), normally open (N.O.) and the normally closed (N.C.) contact. The fan relay can switch up to 5.0A up to 240VAC. (see *OPERATION* section of these *User Instructions* for details on relay settings).

8. The fan relay can be wired to normally open (N.O.) or normally closed (N.C.) and will engage if the fan setting (1, 2, 3, 4, 5, 6, 7, 8, 9, 10 (default), 11, 12, 13, 14, 15, 16, 17, 18, 19, 20% LEL) is exceeded for the fan relay delay time (0, 1, 3 (default), 5, 10 minutes). The fan relay will disengage once both of these conditions have been met: 1. Combustible gas concentration has dropped below fan setting and 2. Fan relay run time (0 (default), 3, 5, 10, 15 minutes) has been exceeded. Note that the “disable” fan setting will cause the fan relay to not engage. The fan relay will engage in troublefault condition and will disengage once troublefault condition is cleared.

9. The Current Loop is 4mA in clean air and 4-20mA for 0-50% LEL.

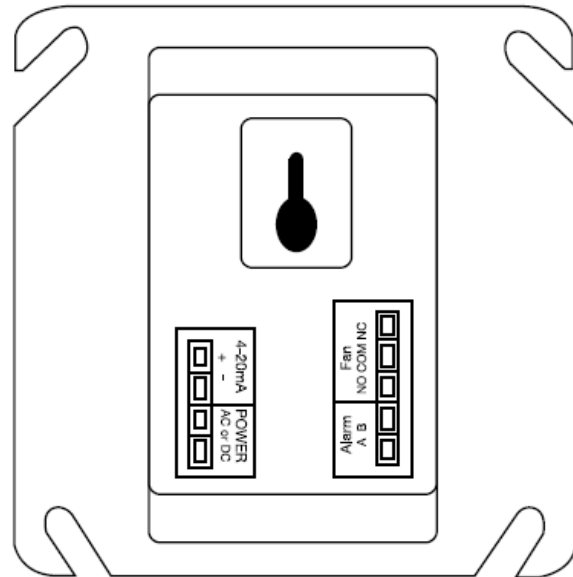
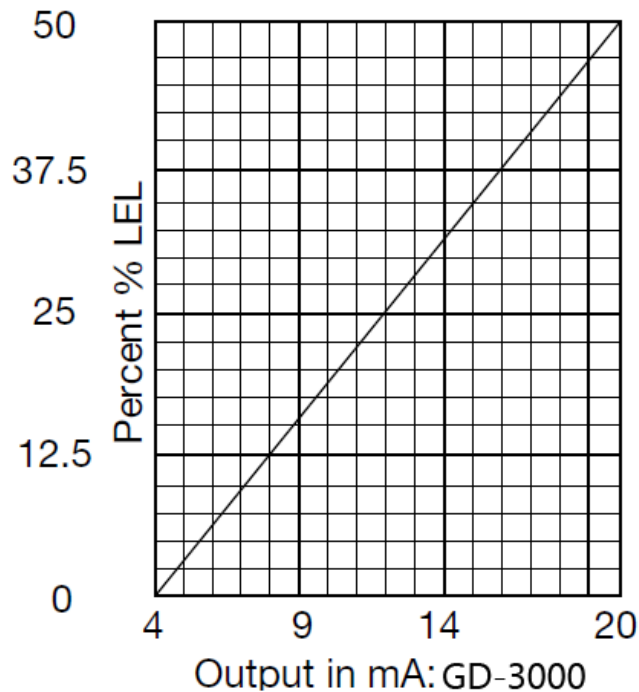

GD-3000 rear view with Modular Connectors

Typical Multiple GD-3000 Combustible Gas Detector Installation

INSTALLATION NOTES

1. One sensor per 900 square feet (approximately).
2. If the gas used is natural gas (methane) or Hydrogen (H₂) mount the Eagle Eye GD-3000 Combustible Gas Detector high on a wall about one foot down from the ceiling. If the gas used is propane (LP), mount the GD-3000 Combustible Gas Detector on a wall or column one foot above the floor.
3. See applicable building code for fan size vs air changes per periods of time.
4. Make sure there are air inlets to provide adequate air flow throughout the building.
5. Eagle Eye GD-3000 Combustible Gas Detector fan relays are dry contact & can switch up to 240V.
6. Several fan relays (starters) may be used. Match the relays to the fan size.

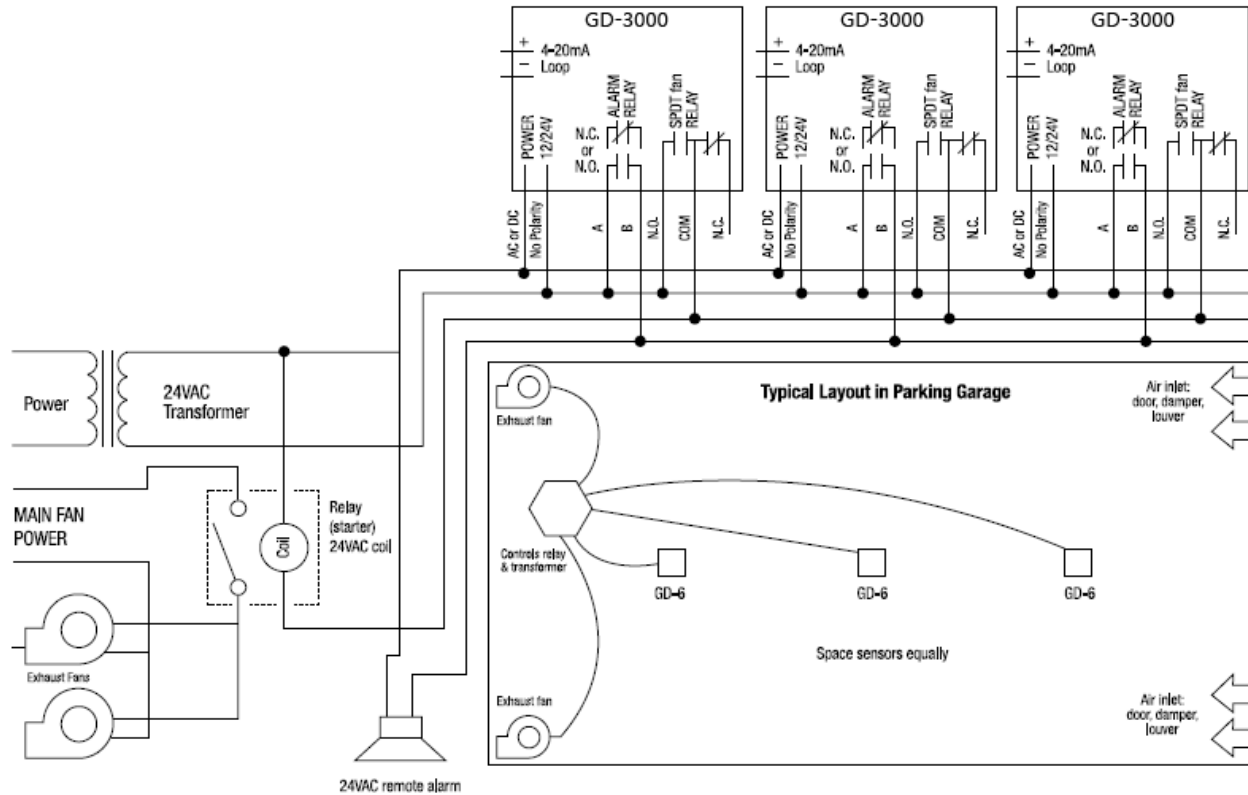

Typical Connection to Alarm Control Panel

1. Eagle Eye GD-3000 Combustible Gas Detector can be used with 12VDC or 24VDC N.O.(fire) panels.
2. Alarm panel provides battery backed up power to Eagle Eye GD-3000 Combustible Gas Detector.
3. Eagle Eye GD-3000 Combustible Gas Detector dry contact fan relay can use panel power or fan power. Check ratings on panel & fan.
4. Match fan relay contacts to fan size, and coil voltage to power source.
5. Alarm Control Panels are available with many features & can control other devices such as smoke detectors, fire detectors & burglar alarms.

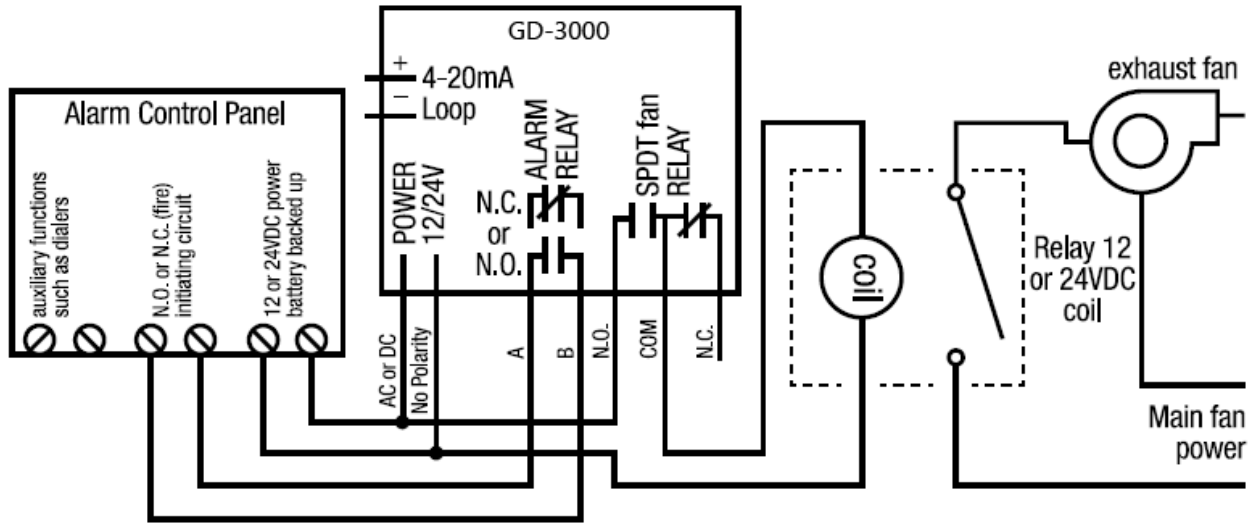

3.4 Power Up

WARNING

Each time the unit is turned on it performs a self-test, which activates visual alarms. If the self-test fails, or if all the alarms do not activate, do not use. Failure to do so may adversely affect product performance and result in sickness or death.

The Eagle Eye GD-3000 Combustible Gas Detector cycles through an internal self-test cycle for the first minute that it is powered. The unit will execute the test cycle any time power is dropped and reapplied (i.e. power failure). During the self-test cycle the unit will display the firmware version number, then count down from 60 to 0 and finally go into normal operation. The fan and alarm relay will be activated for the power-up cycle unless the “Power Up Test” (PUt) option is OFF. The indicator light (LED) will flash green during the self-test cycle. At the end of the 1 minute cycle, the unit will take its first sample of the air and the light will turn solid green.

WARNING

Do not cover or obstruct visual alarm LED. Doing so may adversely affect product performance and **result in sickness or death.**

3.5 Operation

1. With the display function turned “On”, the Eagle Eye GD-3000 Combustible Gas Detector will show the current concentration of gas % LEL or “0” (zero) in clean air. When the gas concentration reaches the Fan Relay setting (10% LEL, for example) the display will flash back and forth between “FAn” and “10”. With the display function turned “Off”, the display does not show the gas concentration, but will show “FAn” as long as the fan relay is activated.
2. With the display function turned “On” and the gas concentration reaching the alarm relay setting, (20% LEL, for example) the display will flash back and forth between “ALr” and “20”. The buzzer will sound indicating “Alarm” if the buzzer is turned “On”. With the display function turned off the display does not show the gas concentration, but will show “ALr” when the Alarm relay is activated.
3. With the 4-20mA function turned “On”, the 4-20mA output will correspond to the concentration (0-50% LEL). The display will show “FAn” and “ALr” and sound as outlined above.

3.6 Default Configuration – Factory Settings

- The default Display setting is Off
- The default Power Up Test setting is On
- The default Buzzer setting is Off
- The default Alarm Relay setting is activation at 20% LEL
- The default Fan Relay Delay setting is 3 minutes
- The default Fan Minimum Runtime setting is OFF
- The default Fan Relay setting is activation at 10% LEL
- The default Alarm Relay Configuration is Normally Open
- The default 4-20mA Output setting is OFF

To change settings, remove the Philips screw on the front of the Eagle Eye GD-3000 Combustible Gas Detector. Pull off the front cover of the unit.

Gas Selection

To select the **Gas Option**, in normal mode, press the **Next** button once to display the current gas selection (**mE is Methane, Pro is Propane and Hy is Hydrogen**). Then press the **Enter** button twice to enter the selection menu. The currently selected gas will be shown on the display. Press **Next** to scroll through the available gases selections. The selected gas will be flashing, press **Enter** to select the gas and **Enter** again to confirm the selection. To return back to normal mode press **Next** until “End” is displayed and press **Enter**.

Selecting Default Configuration – “dEF”

To select the Default Configuration, in normal mode, press the **Next** button twice to get to “Con” or the Configuration menu. Then press the **Enter** button to enter the Con menu. The **first** selection is the “dEF” or Default setting. Press **Enter**. If it is already in Default configuration, there will be no action. If it is not already in Default configuration, “nO” will be displayed. Press **Next** to change it to “YES” (flashing) then press **Enter** to confirm the change (solid) and press **Enter** again to return to “dEF” in the Con menu. Press **Next** until “End” is displayed then press **Enter** to return to normal operation.

Selecting Power Up Test Option – “PUt”

To select the **Power Up Test** Configuration, in normal mode, press the **Next** button twice to get to “Con” or the Configuration menu. Then press the **Enter** button to enter the Con menu. Then press the **Next** button to get to **the second selection** “PUt” or **Power Up Test** setting. Press **Enter**. If the test is “On” press **Next** to turn it “OFF” (flashing) then press **Enter** to confirm the change (solid) and press **Enter** again to return to “PUt” in the Con menu. Press **Next** until “End” is displayed then press **Enter** to return to normal operation.

Selecting Display Option – “dSP”

To select the Display Configuration, in normal mode, press the **Next** button twice to get to “Con” or the Configuration menu. Then press the **Enter** button to enter the Con menu. Then press the **Next** button twice to get to **the third selection** “dSP” or Display setting. Press **Enter**. If the display is “On” press **Next** to turn it “OFF” (flashing) then press **Enter** to confirm the change (solid) and press **Enter** again to return to “dSP” in the Con menu. Press **Next** until “End” is displayed then press **Enter** to return to normal operation.

Selecting Buzzer Option – “bUZ”

To select the Buzzer Configuration, in normal mode, press the **Next** button twice to get to “Con” or the Configuration menu. Then press the **Enter** button to enter the Con menu. **The fourth selection** is the “bUZ” or Buzzer setting. Press **Next** three times to get to “bUZ” then press **Enter**. If the display is “On” press **Next** to turn it “OFF” (flashing) then press **Enter** to confirm the change (solid) and press **Enter** again to return to “bUZ” in the Con menu. Press **Next** until “End” is displayed then press **Enter** to return to normal operation.

Selecting Alarm Relay Setting – “ArS”

To select the Alarm Relay Setting, in normal mode, press the **Next** button twice to get to “Con” or the Configuration menu. Then press the **Enter** button to enter the Con menu.

The **fifth selection** is the “ArS” or Alarm Relay Setting. Press **Next** four times to get to “ArS” then press **Enter**. If the display is “OFF” (disabled) press **Next** to change it to 5, 10, 15, 20 or 25% LEL (flashing) then press **Enter** to confirm the change (solid) and press **Enter** again to return to “ArS” in the Con menu. Press **Next** until “End” is displayed then press **Enter** to return to normal operation.

Selecting Alarm Relay Configuration – “Arc”

To select the **Alarm Relay Configuration**, in normal mode, press the **Next** button twice to get to “Con” or the Configuration menu. Then press the **Enter** button to enter the Con menu. **The sixth selection** is the “Arc” or Alarm Relay Configuration. Press **Next** five times to get to “Arc” then press **Enter**. If the relay is “nO” (normally open) press **Next** to turn it to “nC” (flashing) then press **Enter** to confirm the change (solid) and press **Enter** again to return to “Arc” in the Con menu. Press **Next** until “End” is displayed then press **Enter** to return to normal operation

Selecting Fan Relay Settings – “FrS”

To select the Fan Relay setting, in normal mode, press the **Next** button twice to get to “Con” or the Configuration menu. Then press the **Enter** button to enter the Con menu. **The seventh selection** is the “FrS” or Fan Relay setting. Press **Next** six times to get to “FrS” then press **Enter**. If the fan relay is “OFF” (disabled) press **Next** to change it to 1, 2, 3, 4, 5, 6, 7, 8, 9, 10, 11, 12, 13, 14, 15, 16, 17, 18, 19 or 20% LEL (flashing) then press **Enter** to confirm the change (solid) and press **Enter** again to return to “run” in the Con menu. Press **Next** until “End” is displayed then press **Enter** to return to normal operation.

Selecting Fan Relay Delay – “FrD”

To select the Fan Relay Delay setting, in normal mode, press the **Next** button twice to get to “Con” or the Configuration menu. Then press the **Enter** button to enter the Con menu. **The eighth selection** is the “FrD” or Fan Relay Delay. Press **Next** seven times to get to “FrD” then press **Enter**. If the delay is “OFF” (disabled) press **Next** to change it to 1, 3, 5, or 10 minutes (flashing) then press **Enter** to confirm the change (solid) and press **Enter** again to return to “FrD” in the Con menu. Press **Next** until “End” is displayed then press **Enter** to return to normal operation.

Selecting Fan Minimum Run Time – “Frr”

To select the Fan Minimum Runtime setting, in normal mode, press the **Next** button twice to get to “Con” or the Configuration menu. Then press the **Enter** button to enter the Con menu. **The ninth selection** is the “Frr” or Fan Minimum Run Time. Press **Next** eight times to get to “Frr” then press **Enter**. If the runtime is “OFF” (disabled) press **Next** to change it to 3, 5, 10 or 15 minutes (flashing) then press **Enter** to confirm the change

(solid) and press **Enter** again to return to “run” in the Con menu. Press **Next** until “End” is displayed then press **Enter** to return to normal operation.

Selecting 4-20mA Output Option – “420” To select the **4-20mA Output Option**, in normal mode, press the **Next** button twice to get to “Con” or the Configuration menu. Then press the **Enter** button to enter the Con menu. **The tenth selection** is the “420” or 4-20mA Output Option. Press **Next** nine times to get to “420” then press **Enter**. If the 4-20mA is “On” press **Next** to turn it to “OFF” (flashing) then press **Enter** to confirm the change (solid) and press **Enter** again to return to “420” in the Con menu. Press **Next** until “End” is displayed then press **Enter** to return to normal operation.

3.7 Onboard Diagnostics

The Eagle Eye GD-3000 Combustible Gas Detector monitors all critical functions of the unit through software diagnostics that continuously test and verify unit operations. If a problem is found, the unit will switch to a fail-safe/error mode or trouble condition. In this error mode, the Fan and Alarm relays will be activated; the 4-20mA current loop will go to 24mA and the LED light will Flash Green. This is a safety precaution. To clear this mode, simply turn off power to the unit for a few seconds, or press the TEST switch (inside the unit). This will cause the unit to restart the 1 minute self-test cycle.

The 4-20mA signal can be used for troubleshooting:

- 0mA is most likely a connection problem
- 4-20mA is normal gas reading range (0-50% LEL)
- 24mA indicates a Trouble condition

Error Codes

- t01 Sensor is missing
- t02 Temperature compensation failed
- t04 Bad EEPROM checksum
- t08 Sensor is shorted
- t10 Bad EEPROM
- t20 Bad factory calibration
- t40 Factory calibration was not done
- t80 SDADC reading failed

If the error mode repeats frequently, check for continuous power and proper voltage. If power is not the problem and a unit has repeating error conditions, it may need to be returned to Eagle Eye for service, as noted in these *User Instructions*.

3.8 Sensor Poisons

The gas sensor in the detector is designed with extreme sensitivity to the environment. As a result, the sensing function may be deteriorated if it is exposed to a direct spray from aerosols such as paints, silicone vapors, etc., or to a high density of corrosive gases (such as hydrogen sulfide, sulfur dioxide) for an extended period of time.

4. MAINTENANCE

The Eagle Eye GD-3000 Combustible Gas Detector does not require regular maintenance other than cleaning. The unit uses a long life pellistor sensor that has a 5+ year life expectancy.

WARNING

Do not disassemble unit or attempt to repair or modify any component of this instrument. This instrument contains no user serviceable parts, and substitution of components may impair intrinsic safety, which may adversely affect product performance and **result in sickness or death.**

CAUTION

- Avoid the use of harsh cleaning materials, abrasives and other organic solvents. Such materials may permanently scratch the surfaces and damage the display window, labels, or instrument housing.

4.1 Cleaning

Cleaning of the external surfaces is best carried out using a damp cloth with a mild detergent or soap. Vacuum under the cover with soft brush to remove dust or contamination.

4.2 Testing

Using a certified gas with a concentration other than the one listed for this instrument and sensor when conducting a calibration or calibration verification test (bump test) will produce inaccurate readings. This means that higher levels of the gas being monitored may be present and could result in overexposure and cause sickness or death.

General

There are multiple ways to test the Eagle Eye GD-3000 Combustible Gas Detector after installation: Operation Test, Manual Operation Test, Combustible Gas Test and Quick Gas Test. The GD-3000 Combustible Gas Detector also has the ability to test itself automatically and does so every 2 1/2 minute cycle. If the unit detects an improper voltage or inoperable component it will default into Error mode. In Error mode, the unit will Flash Green and both the fan & alarm relay will be actuated. Check that the GD-3000 Combustible Gas Detector OPERATING LED type light is illuminated, continuously. If not, do not proceed with the tests. If the unit is in error mode contact your local representative Eagle Eye technical support.

4.2.1 Operation Test

1. Remove the single screw in the middle of the front cover of the Eagle Eye GD-3000 Combustible Gas Detector.
2. Remove the front cover.
3. Observe the LED light on the front of the Eagle Eye GD-3000 Combustible Gas Detector.
4. If the light is solid green proceed to step 6.
5. If the light is off or flashing Green, refer to the General section of this *User Instruction*.
6. Locate the switch labeled ENTER/TEST on the left side of the printed circuit board. Press the Test switch once.
7. The Eagle Eye GD-3000 Combustible Gas Detector will step through a cycle test:
 - a. The display progresses through the **Art** (alarm relay test), **Frnt** (fan relay test) then **4-20mA** (4-20mA output test).
 - b. During the first 5 seconds of the test cycle, the alarm relay will be closed, so any devices connected to that relay will be tested.
 - c. The Fan relay will be activated for the next 1 minute of the test, so if the fan circuits are wired in the normal manner, the fan should run.
 - d. The 4-20mA output will then ramp up from 4 to 20mA over the next 130 seconds of the test, so if the circuit is wired in the normal manner, the control panel or building automation system should respond.
 - e. At the end of the test cycle, the light will turn green and be on steady (Normal Operation), the fan & alarm relay will be in standby mode and the 4-20mA output will return to 4mA (in clean air).
8. When testing is completed reassemble the unit or units.

4.2.2 Manual Operation Test

This option gives the user the opportunity to manually initiate an individual test for each relay, the analog output and the sensor response to gas. From normal operation mode

press the **Next** button 3 times to get to the Test Mode (tSt). Press the **Enter** button once to get into the Test Menu. Press the **Next** button to scroll through the four test options and press **Enter** to initiate the selected test. Note that if the relay or 4–20mA output has been disabled, the test selection will not be displayed in the test menu.

Art - Alarm Relay Test, 10 seconds

Frt - Fan Relay Test, 60 seconds

42t - 420 loop test, 25 seconds

gtS - Gas Test, 3 minutes (no output to the panel during the gas test)

The display will flash during the test or in the case of the gas test the level will alternate with the expected gas (**mE**, **Pro** or **Hy**). Once the test is complete, the display will return to steady display. To exit the test menu, press the **Next** button until “End” is displayed then press **Enter** to return to normal mode.

4.2.3 Combustible Gas Test

The following steps must be performed when conducting a calibration or calibration verification test (bump test) to ensure proper performance of the monitor. Failure to do so may adversely affect product performance and **result in sickness or death**.

- When performing a calibration or calibration verification test (bump test) only use certified calibration gas at the required concentration level. Do not calibrate with expired calibration gas.
- If the instrument cannot be calibrated, do not use until the reason can be determined and corrected.
- Do not cover or obstruct display, audible alarm opening or visual alarm cover.
- Ensure sensor inlet is unobstructed and is free of debris.

General

The Eagle Eye GD-3000 Combustible Gas Detector can be bump-tested or calibrated with a Field Calibration Kit (FCK) with Methane, Propane or Hydrogen gas, regulator and test hood, available through your local representative or from Eagle Eye.

FCK Information

Several detectors can be calibrated with one FCK. The only limitation is the amount of gas in the cylinder. The 17 liter cylinder with 0.2 LPM (Liters Per Minute) regulator has approximately 85 minutes of continuous calibration run time. Replacement cylinders are

available. The gas cylinder should be replaced when the pressure gauge on the regulator shows 25psi or less.

Note: For optimum test results it is suggested that the unit be in clean air (solid green light on) and be in a low ambient air flow.

Gas Testing

Testing the Fan Relay

Note: The gas concentration to activate the fan relay depends on the setting.

1. Remove the Philips screw on the front of the Eagle Eye GD-3000 Combustible Gas Detector. Remove the front cover.
2. Connect the 10% LEL cylinder of Combustible Gas to the regulator. Ensure that the gas used for calibration matches the gas selected in the Eagle Eye GD-3000 Combustible Gas Detector configuration.
3. Assemble regulator, hose and test hood and place the test hood over the gas sensor.
4. Check the pressure gauge on the regulator. If you have 25psi or less you will need to replace the gas canister.

Note: The time to activate the fan relay depends on the delay setting.

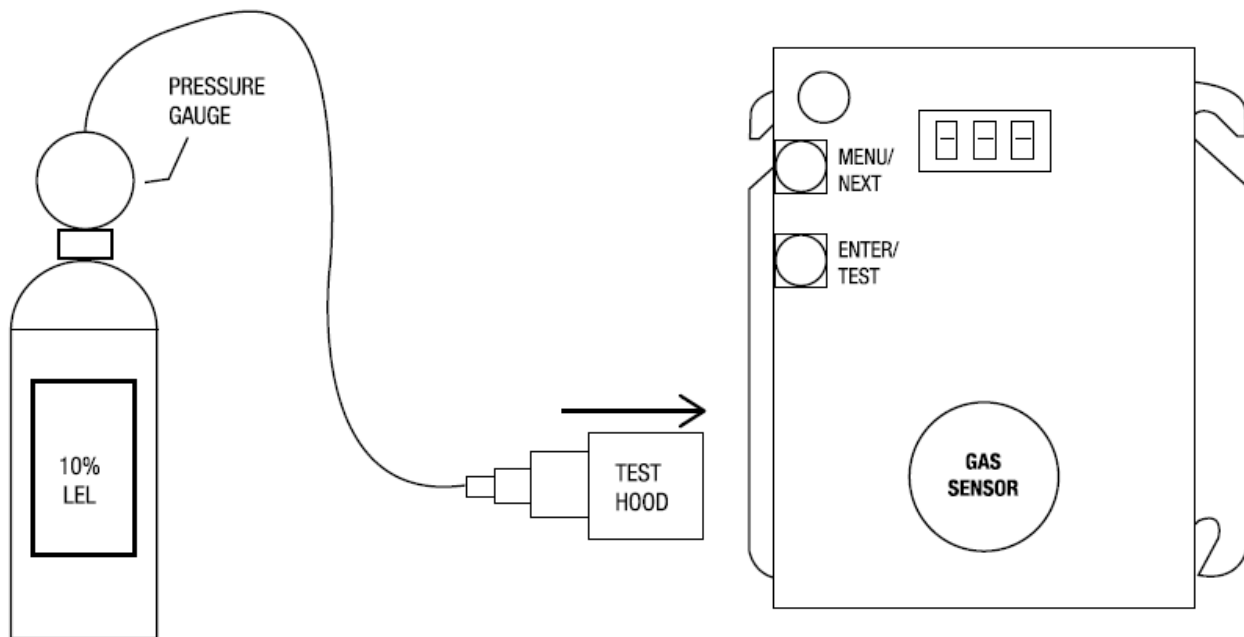

5. Turn on the regulator to start the gas flow and wait with the gas applied continuously.
6. With the display function turned "On", the Eagle Eye GD-3000 Combustible Gas Detector will show the current concentration of gas or "0" (zero) in clean air. When the gas concentration reaches the fan relay setting (5% LEL, for example) the display will

flash back and forth between “FAn” and “5”. With the display function turned ”Off”, the display does not show the gas concentration, but will show “FAn” as long as the fan relay is activated

Note: If the Fan relay does not close within 2 minutes, consider these possibilities:

- a. Gas cylinder is empty, check the pressure gauge. Replace the gas cylinder if 25psi or less.
 - b. Unit needs to be re-calibrated (go through recalibration and re-test).
 - c. Detector is in need of servicing (return unit to factory for servicing).
 - d. Detector has fan relay set to disable (OFF) or 20% LEL. Set fan relay to 5% LEL and repeat the test.
7. Remove the gas from the sensor. Proceed to test the alarm relay or replace the top cover.

Testing the Alarm Relay

Note: The gas concentration to activate the Alarm relay depends on the setting.

Connect the 20% LEL cylinder of Combustible Gas to the regulator. Ensure that the gas used for calibration matches the gas selected in the Eagle Eye GD-3000 Combustible Gas Detector configuration.

1. Check the pressure gauge. If there is 25psi or less the cylinder should be replaced.
2. Place the test hood over the gas sensor. Turn on the regulator to start the gas flow.
3. The Fan relay should activate according to the settings.
4. With the display function turned “On” and the gas concentration reaching the Alarm Relay setting, (20% LEL, for example) the display will flash back and forth between “ALr” and “20”. The buzzer will sound indicating “Alarm” if the buzzer is turned “On”. With the display function turned off the display does not show the gas concentration, but will show “ALr” when the Alarm relay is activated.

5. Note: If the Alarm relay fails to operate within 2 minutes, consider these possibilities:

- a. Gas cylinder is empty, check the pressure gauge. Replace the gas cylinder if 25psi or less.
 - b. Unit needs to be re-calibrated (go through recalibration and re-test).
 - c. Detector is in need of servicing (return unit to factory for servicing).
 - d. Detector has Alarm relay set to disable (OFF). Set Alarm relay to 20% LEL and repeat the test.
6. Remove the gas from the sensor after test. Proceed to test the 4-20mA output or replace the top cover.

Testing the 4-20mA current loop

Connect the 20% LEL cylinder of Combustible Gas to the regulator. Ensure that the gas used for calibration matches the gas selected in the Eagle Eye GD-3000 Combustible Gas Detector configuration.

1. Check the pressure gauge. If there is 25psi or less the cylinder should be replaced.
2. Place the test hood from the regulator over the gas sensor. Turn on the regulator to start the gas flow.
3. The fan relay should activate according to the settings.
4. The alarm relay should activate according to the settings.
5. The 4-20mA output should ramp up from 4mA in clean air to 20mA at 50% LEL. See 4-20mA diagram in these *User Instructions*.

Note: If the 4-20mA output does not ramp up within 2 minutes, consider these possibilities:

- a. Gas cylinder is empty, check the pressure gauge. Replace the gas cylinder if 25psi or less.
 - b. Unit needs to be re-calibrated (go through recalibration and re-test).
 - c. Detector is in need of servicing (return unit to factory for servicing).
 - d. Detector has 4-20mA option set to "OFF". Set 4-20mA option to "On" and repeat the test.
6. Remove the gas from the sensor. Re-assemble the Eagle Eye GD-3000 Combustible Gas Detector (make sure the LED is aligned with the hole on the front of the case).

4.2.4 Quick Gas Test

A cigarette lighter can be used to perform a functionality test of the Eagle Eye GD-3000 Combustible Gas Detector. This test allows installers to do a quick functionality test of the gas sensor.

1. Units to be tested must be powered continuously for a minimum of 3 minutes before proceeding.
2. For optimum test results, the unit should be in clean air and be in a low ambient air flow.
3. Check that the Eagle Eye GD-3000 Combustible Gas Detector status indicator light is illuminated green continuously. If not, do not proceed with tests. See Eagle Eye GD-3000 Combustible Gas Detector *Trouble Indicator* section in these *User Instructions*.
4. The display option should be set to "On" and reading 0% LEL in clean air.
5. Aim the lighter into the sensor grate area (under "DO NOT PAINT") on the front cover and release the gas without igniting the flame for 2 to 3 seconds.

6. Wait for a few seconds. The digital display should climb indicating the increased gas concentration at the sensor confirming a pass of the quick test.

Note: If the Display does not change within 10 seconds, consider these possibilities:

- a. Lighter is empty.
 - b. Unit needs to be re-calibrated (go through the *Field Calibration Procedure* in these *User Instructions* and re-test).
 - c. Detector is in need of servicing (return unit to factory for servicing).
7. Wait for the display to return to 0% LEL and configure options to desired settings.

4.3 Field Calibration Procedure

Note: For optimum calibration results the unit should be in clean air and be in a low ambient air flow.

Using a certified gas with a concentration other than the one listed for this instrument and sensor when conducting a calibration or calibration verification test (bump test) will produce inaccurate readings. This means that higher levels of the gas being monitored may be present and could result in overexposure and cause sickness or death.

4.3.1 Zero the Sensor

1. Remove the Philips screw on the front of the Eagle Eye GD-3000 Combustible Gas Detector. Pull the front cover of the unit off.
2. To select Calibration Zero Mode (**000**), from normal mode, press the **Next** button four times to get to **CAL** or Calibration Mode.
3. Then press the **Enter** button to get to “**000**” - Calibration Zero Mode.
4. Press the **Enter** button and the display will read **0** alternating with **000** (blinking) indicating zero calibration in progress (max 165 sec).
5. If the process is successful, the display will read **__0** alternating with **PAS** (blinking) Zero Calibration complete.
6. If the process was not successful the display will read **__1** alternating with **Fail** (blinking) Zero Failed. If this occurs, repeat steps 2 through 4. If the sensor fails to zero twice contact Technical Assistance: 1-800-237-9049.
7. To return to Normal Mode press **Enter** and then press **Next** until “End” is displayed. Press **Enter** to return to Normal Mode.

4.3.2 Calibration

1. Remove the Philips screw on the front of the Eagle Eye GD-3000 Combustible Gas Detector. Pull the front cover of the unit off.

2. Assemble the 10% LEL gas cylinder and regulator together. Ensure that the gas used for calibration matches the gas that the GD-3000 Combustible Gas Detector is configured to (mE, Pro or Hy).
 3. Check the pressure gauge on the regulator. If you have 25psi or less you will need to replace the gas canister.
 4. Place the test Hood from the regulator over the gas sensor.
 5. To select Calibration Span Mode (**SPn**), from normal mode, press the **Next** button four times to get to **CAL** or Calibration Mode.
 6. Press the **Enter** button to get to “**000**” Calibration Zero Mode, then press the **Next** button to get to “**SPn**” – Calibration Span Mode.
 7. Press the **Enter** button and the display will read **10** alternating with the gas, **mE**, **Pro** or **Hy** (blinking), indicating the sensor is looking for gas.
 8. Start applying gas to the gas sensor.
- Note: The sensor will look for the gas for 45 seconds. If no gas is applied or detected in that time, the display will return to CAL.**
9. When the sensor detects the gas, the display will flash back and forth between the **gas concentration** and **SPn** and the calibration will progress. The display will show this for a maximum of 165 seconds.
 10. When the calibration is successful, the display will flash back and forth between **10** and **PA S**.
 11. Remove the gas. The display will return to “**SPn**”, then normal mode. The calibration is done.
 12. If the calibration fails, the display will flash back and forth between the gas concentration and **FAL** (fail). If this occurs, check the pressure gauge on the regulator. If the pressure is less than 25psi the flow of gas may not be adequate to properly calibrate the unit. If there is proper pressure in the cylinder repeat steps 4 through 11. If the unit fails to calibrate twice contact Eagle Eye.
 13. Disassemble the cylinder and regulator.
 14. Re-assemble the Eagle Eye GD-3000 Combustible Gas Detector (make sure the LED is aligned with the hole in the front case).
 15. See Calibration Flowchart.

5. EAGLE EYE FIXED GAS DETECTION PRODUCTS LIMITED WARRANTY

Eagle Eye warrants the GD-3000 gas detector will be free from defective materials and workmanship for a period of two (2) years from date of manufacture (indicated on the inside cover of the GD-3000), provided it is maintained and used in accordance with Eagle Eye instructions and/or recommendations. If any component becomes defective

during the warranty period, it will be replaced or repaired free of charge, if the unit is returned in accordance with the instructions below. This warranty does not apply to units that have been altered or had repair attempted, or that have been subjected to abuse, accidental or otherwise. The above warranty is in lieu of all other express warranties, obligations or liabilities. THE IMPLIED WARRANTIES OF MERCHANTABILITY AND FITNESS FOR PARTICULAR PURPOSE ARE LIMITED TO A PERIOD OF TWO (2) YEARS FROM THE PURCHASE DATE. Eagle Eye shall not be liable for any incidental or consequential damages for breach of this or any other warranty, express or implied, arising out of or related to the use of said gas detector. Manufacturer or its agent's liability shall be limited to replacement or repair as set forth above. Buyer's sole and exclusive remedies are return of the goods and repayment of the price, or repair and replacement of non-conforming goods or parts.

6. CONTACT EAGLE EYE POWER SOLUTIONS



Sales & Support

info@eepowersolutions.com
office: 414-962-3377
toll free: 1-877-805-3377

4031 W. Kiehnau Ave
Milwaukee, WI 53209

Your Partner In Critical Power Solutions