



**LB-60-100D
LOAD BANK**

**MANUAL CONTAINS
OPERATING INSTRUCTIONS
PARTS LIST
WIRING DIAGRAMS
SERVICE INSTRUCTIONS**

**EAGLE EYE POWER SOLUTIONS, LLC
4031 W Kiehnau Ave
Milwaukee, WI 53209
877-805-3377**

This load bank is manufactured and protected under U. S. Patent number 4,445,047

THIS LOAD BANK IS DESIGNED FOR THE TESTING AND SERVICING 480/208V 60HZ POWER UNITS. THESE UNITS HAVE THE POTENTIAL OF DELIVERING A LETHAL SHOCK. THIS LOAD BANK SHOULD BE USED ONLY BY TRAINED AND QUALIFIED PERSONNEL. THIS LOAD BANK IS DESIGNED FOR TEMPORARY USE ONLY. THE LOAD RESISTORS ARE ENERGIZED WHEN THE RATE SWITCH IS OFF, THEREFORE DO NOT INSERT ANY OBJECTS IN THE GRILL ASSEMBLY. DO NOT BLOCK THE AIR FLOW OR USE IF THE AIR FLOW IS REVERSED.

TABLE OF CONTENTS

<u>SUBJECT</u>		<u>SECTION</u>	<u>PAGE</u>
DESCRIPTION			
PURPOSE OF LOAD BANK		1 - 1	1
RATING OF LOAD BANK		1 - 2	1
LOAD BANK DESCRIPTION	FIGURE 1 - 1	1 - 3	1
CONTROL PANEL LAYOUT	FIGURE 1 - 2	1	2
CONTROL DESCRIPTION		1 - 4	3
OPERATION			
TESTING 120VAC SINGLE PHASE		2	1
TESTING 240VAC SINGLE PHASE		2	3
TESTING 208VAC THREE PHASE		2	5
TESTING 240VAC THREE PHASE		2	7
TESTING 480VAC THREE PHASE		2	9
PARTS			
PARTS INFORMATION		3	1
CONTROL PANEL PARTS LAYOUT	FIGURE 3 - 1	3	2
CONTROL PANEL PARTS LIST		3	3
INTERIOR PARTS LAYOUT	FIGURE 3 - 2	3	4
INTERIOR PARTS LIST		3	5
FAN PANEL PARTS LAYOUT	FIGURE 3 - 3	3	6
FAN PANEL PARTS LIST		3	7
VENDOR LIST		3	8
SERVICING			
GENERAL SERVICING		4 - 1	1
REPLACING FAN	FIGURE 4 - 1	4 - 2	2
WIRING DIAGRAMS			
INTERIOR WIRING	FIGURE 5 - 1	5	1
FAN PANEL WIRING	FIGURE 5 - 2	5	3
SCHEMATIC DIAGRAM	FIGURE 5 - 3	5	5

1-1 PURPOSE OF LOAD BANK: The LB-60-100D is a portable load bank designed to be used for field servicing and testing 60HZ generators and UPS systems. It can be used for checking cables after they have been replaced or repaired. The load bank can also be shipped to different locations using the carrying case.

1-2 RATING OF LOAD BANK: The LB-60-100D is rated at 100KW full load when the input voltage is 480VAC and 80 KW when the input voltage is 208VAC with all five load steps turned on. The load steps are 12.5KW, 12.5KW, 25KW, 25KW and 25KW at 480VAC, 5KW or 10KW, 10KW, 20KW, 20KW, 20KW at 208VAC. All steps are continuous. This unit can be used for 60HZ and 400HZ testing.

1-3 LOAD BANK DESCRIPTION: The load bank is uses a 120VAC power source to operate other than the power being tested. The different sides of the load bank are shown in fig. 1-1. The air enters the right side (fan side) and exits the left side.



FIGURE 1-1

LENGTH	22 IN.
WIDTH	8 IN.
HEIGHT	21 IN.
WEIGH	60 LBS.

CONTROL PANEL PARTS

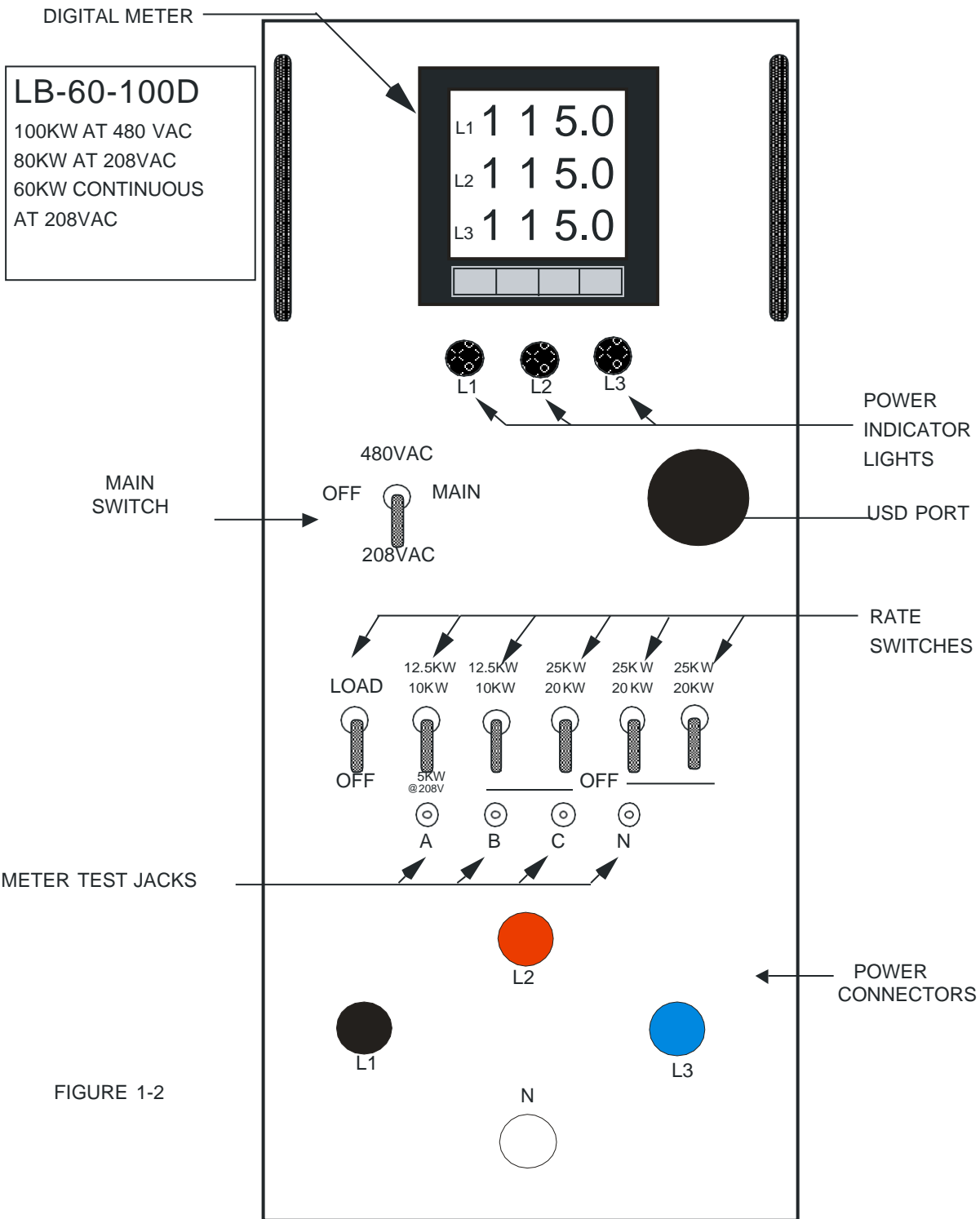

FIGURE 1-2

1-4 CONTROL DESCRIPTION: The following is a description of the controls on the control panel (see figure 1-2 on page 2.

DIGITAL MULTIMETER - A three phase meter used to measure, Phase Voltage (V),Phase to Neutral (V), Frequency (Hz),Phase Current (I),Neutral Current (I),Active Power (W),Reactive Power (Var), Apparent Power (VA), Power Factor (P.F.), Active Energy (W.h), Reactive Energy Var.h), Instantaneous Demand Amp, Instantaneous Demand Active Power, Instantaneous Demand Apparent Power, Maximum Demand Amps, Maximum Demand Active Power, Maximum Demand Apparent Power. The meter should read approximately 208 volts line to line or 480 volts line to line.

RATE SWITCHES - Switch used to select the desired rate on the load bank. The rates are as follows:

480VAC		208VAC	
1.	12.5 KW balanced load	1.	5 KW or 10 KW balanced load
2.	12.5 KW balanced load	2.	10 KW balanced load
3.	25 KW balanced load	3.	20 KW balanced load
4.	25 KW balanced load	4.	20 KW balanced load
5.	25 KW balanced load	5.	20 KW balanced load

POWER INDICATOR LIGHTS - These lights will light to indicate power on A, B, and C phase. All three lights should be on when testing three phase circuits.

METER TEST JACKS - This provides a place to connect an external meter. There is a test jack for each cable pin.

POWER RECEPTACLE - The power cable from the equipment to be tested is plugged into the load bank through the receptacle.

USB PORT- For monitoring and logging of meter data. Programs are included on USB jump drive located on handle of load bank.

120 VOLT POWER RECEPTACLE - A power cable is provided to plug the unit into a 120VAC outlet.
(Not shown on drawing)

OPERATION

TESTING 120VAC SINGLE PHASE

2-1 SETTING UP THE LOAD BANK - Place the load bank in an area free from fuel, oil, or any other flammable substance. The load bank should be positioned so that any strong wind or air currents will flow with the air flow of the load bank.

2-2 APPLYING POWER - The load bank should be connected to the power unit to be tested with an output of 120VAC single phase. Make sure that the power unit is off before connecting the cable to the load bank. Use L1 (Black), L2 (Red) and N (White), when testing single phase circuits. L1 should be connected to the line out, L2 should be connected to neutral and the N cable should be connected to the ground of the unit being tested. Plug the power cable plug in to the load bank. The meter switch should be in the L1-L2 position. Turn on the output of the power unit.

2-3 CHECKING THE POWER - check the following:

- A. The amber light, "A" should be on.
- B. The VOLTS should read 120VAC on "A" phase.
- C. The FREQUENCY should read approximately 60HZ.
- D. The AMPS should read 0A.

2-4 APPLYING THE LOAD - If the above steps checked OK, turn on the main switch to 208VAC. The fans should start up and the airflow should be as indicated by the airflow arrow. Next turn on the load switch. Add the load desired with the rate switch.

- A. Step 1 is 1.7KW
- B. Step 2 is 1.7KW
- C. Step 3 is 3.3KW
- D. Step 4 is 3.3KW
- E. Step 5 is 3.3KW

Total load at 120VAC is 13.3KW.

Check to see that the voltage and frequency does not drop beyond acceptable limits under load.

2-5 SHUTTING DOWN - Turn the load switch and rate switches to the off position and allow the load bank to cool down before turning the main switch to off. Turn the power unit off and disconnect the power cable plug.

OPERATION

TESTING 240VAC SINGLE PHASE

2-1 SETTING UP THE LOAD BANK - Place the load bank in an area free from fuel, oil, or any other flammable substance. The load bank should be positioned so that any strong wind or air currents will flow with the air flow of the load bank.

2-2 APPLYING POWER - The load bank should be connected to the power unit to be tested with an output of 240VAC single phase. Make sure that the power unit is off before connecting the cable to the load bank. Use L1 (Black), L2 (Red) and N (White) when testing 240VAC single phase circuits. Plug the power cable plug in to the load bank and connect the L1 cable to L1 on the power unit, the L2 cable to L2 on the power unit and N to the ground on the power unit. The meter switch should be in the L1-L2 position. Turn on the output of the power unit.

2-3 CHECKING THE POWER - check the following:

- A. The amber light, "A" and "B" should be on.
- B. The VOLTS should read 240VAC on "A" and "B" phase.
- C. The FREQUENCY should read approximately 60HZ.
- D. The AMPS should read 0A.

2-4 APPLYING THE LOAD - If the above steps checked OK, turn the main switch to 208VAC. The fans should start up and the airflow should be as indicated by the airflow arrow. Next turn on load switch. Add the load desired with the rate switch.

- A. Step 1 is 6.6KW
- B. Step 2 is 6.6KW
- C. Step 3 is 13.2KW
- D. Step 4 is 13.2KW
- E. Step 5 is 13.2KW

Total load at 240Vac single phase is 52.8KW

Check to see that the voltage and frequency does not drop beyond acceptable limits under load.

2-5 SHUTTING DOWN -Turn the load and rate switches to off, allow the load bank to cool down before turning the main switch to off. Turn the power unit off and disconnect the power cable plug.

OPERATION

TESTING 208VAC THREE PHASE

2-1 SETTING UP THE LOAD BANK - Place the load bank in an area free from fuel, oil, or any other flammable substance. The load bank should be positioned so that any strong wind or air currents will flow with the air flow of the load bank.

2-2 APPLYING POWER - The load bank should be connected to the power unit to be tested with an output of 208VAC 3 phase, plug in the 120VAC power cord. Make sure that the main switch and the load switch is set to off before connecting the cable to the load bank. Use L1 (Black), L2 (Red), L3 (Blue) and N (White), when testing 208VAC 3 phase circuits. Plug the power cable plug in to the load bank. Turn on the output of the power unit.

2-3 CHECKING THE POWER - check the following:

- A. The amber light, "A", "B", "C" should be on.
- B. The VOLTS should read 208VAC.
- C. The FREQUENCY should read approximately 60HZ.
- D. The AMPS should read 0A.

2-4 APPLYING THE LOAD - If the above steps checked OK, turn the main switch to 208VAC. The fans should start up and the airflow should be as indicated by the airflow arrow. Next turn on the load switch. Add the load desired with the rate switch.

- A. Step 1 is 10KW UP or 5KW DOWN
- B. Step 2 is 10KW
- C. Step 3 is 20KW
- D. Step 4 is 20KW
- E. Step 5 is 20KW

Check to see that the voltage and frequency does not drop beyond acceptable limits under load. Return the rate switch to the off position.

2-5 SHUTTING DOWN - Return the load and rate switches to the off position and, allow the load bank to cool down before turning the power unit off. Turn the power unit off and disconnect the power cable plug.

OPERATION

TESTING 240VAC THREE PHASE

2-1 SETTING UP THE LOAD BANK - Place the load bank in an area free from fuel, oil, or any other flammable substance. The load bank should be positioned so that any strong wind or air currents will flow with the air flow of the load bank.

2-2 APPLYING POWER - The load bank should be connected to the power unit to be tested with an output of 240VAC 3 phase, plug in the 120VAC power cord. Make sure that the main switch and the load switch is set to off before connecting the cable to the load bank. Use L1 (Black), L2 (Red), L3 (Blue) and N (White), when testing 240VAC 3 phase circuits. Plug the power cable plug in to the load bank. Turn on the output of the power unit.

2-3 CHECKING THE POWER - check the following:

- A. The amber light, "A", "B", "C" should be on.
- B. The VOLTS should read 240VAC.
- C. The FREQUENCY should read approximately 60HZ.
- D. The AMPS should read 0A.

2-4 APPLYING THE LOAD - If the above steps checked OK, turn the main switch to 208VAC. The fans should start up and the airflow should be as indicated by the airflow arrow. Next turn on the load switch. Add the load desired with the rate switch.

- | | | |
|--------------|------|----|
| A. Step 1 is | 12.5 | KW |
| B. Step 2 is | 12.5 | KW |
| C. Step 3 is | 25 | KW |
| D. Step 4 is | 25 | KW |
| E. Step 5 is | 25 | KW |

Check to see that the voltage and frequency does not drop beyond acceptable limits under load.

2-5 SHUTTING DOWN - Return the load and rate switches to the off position and, allow the load bank to cool down before turning the power unit off. Turn the power unit off and disconnect the power cable plug.

OPERATION

TESTING 480VAC THREE PHASE

2-1 SETTING UP THE LOAD BANK - Place the load bank in an area free from fuel, oil, or any other flammable substance. The load bank should be positioned so that any strong wind or air currents will flow with the air flow of the load bank.

2-2 APPLYING POWER - The load bank should be connected to the power unit to be tested with an output of 480VAC 3 phase, plug in the 120VAC power cord. Make sure that the main switch and the load switch is set to off before connecting the cable to the load bank. Use L1 (Black), L2 (Red), L3 (Blue) and N (White), when testing 480VAC 3 phase circuits. Plug the power cable plug in to the load bank. Turn on the output of the power unit.

2-3 CHECKING THE POWER - check the following:

- A. The amber light, "A", "B", "C" should be on.
- B. The VOLTS should read 480VAC.
- C. The FREQUENCY should read approximately 60HZ.
- D. The AMPS should read 0A.

2-4 APPLYING THE LOAD - If the above steps checked OK, turn the main switch to 480VAC. The fans should start up and the airflow should be as indicated by the airflow arrow. Next turn on the load switch. Add the load desired with the rate switch.

- A. Step 1 is 12.5 KW
- B. Step 2 is 12.5 KW
- C. Step 3 is 25 KW
- D. Step 4 is 25 KW
- E. Step 5 is 25 KW

Check to see that the voltage and frequency does not drop beyond acceptable limits under load.

2-5 SHUTTING DOWN -Return the load and rate switches to the off position and allow the load bank to cool down before turning the power unit off. Turn the power unit off and disconnect the power cable plug.

PARTS INFORMATION

The following pages list the parts used in the load bank. All of the major parts are shown. Wire, screws, bolts, and small miscellaneous hardware are not listed. Parts that are purchased from a vendor will show a vendor name. These names refer to the vendor list is on page 8.

A part number can be found by first locating the part on a drawing. After finding the part use the number to refer to the parts list on the opposite page. Each part will have a drawing number, Load Banks part number, description and the number used for each load bank.

Parts should be ordered from the address below giving the machine model number, part number and the description.

CONTROL PANEL PARTS

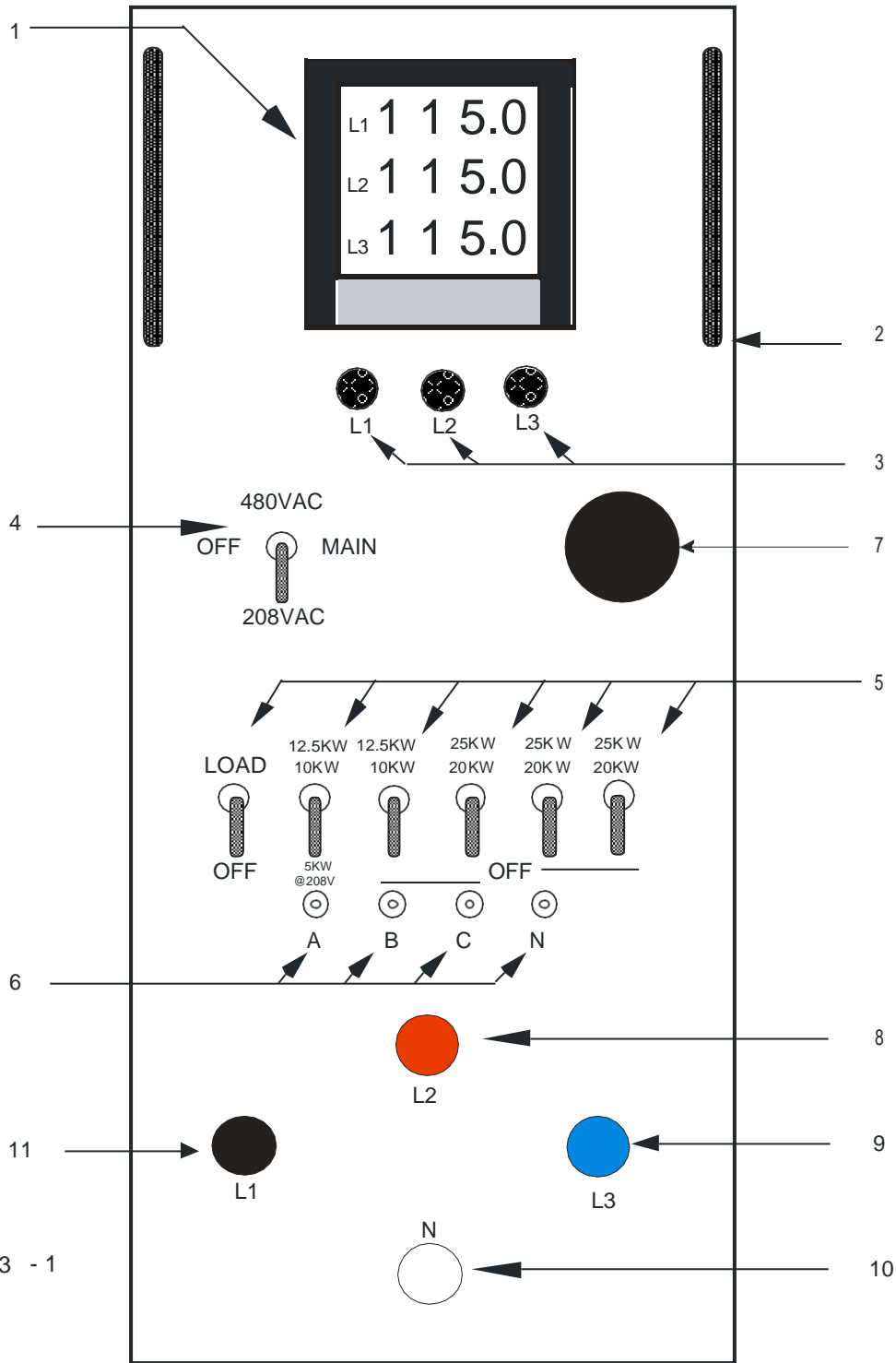

FIGURE 3 - 1

CONTROL PANEL PARTS
FIGURE 3-1

DRAWING NUMBER	PART NUMBER	DESCRIPTION VENDOR NO.	NUMBER USED
1	MR-D60	0 - 600V DIGITAL METER	1
2	HD-25	HANDLE	2
3	LT-25	250VAC AMBER LIGHT	3
4	SW-69	TOGGLE SWITCH DPDT, DELAY	1
5	SW-22	TOGGLE SWITCH DPST	6
6	TP-10	TEST PIN	4
7	PL-08	USB PORT	1
8	CA-02	RED MALE CAM-LOC	1
9	CA-12	BLUE MALE CAM-LOC	1
10	CA-05	WHITE MALE CAM-LOC	1
11	CA-00	BLACK MALE CAM-LOC	1

INTERIOR PARTS LAYOUT

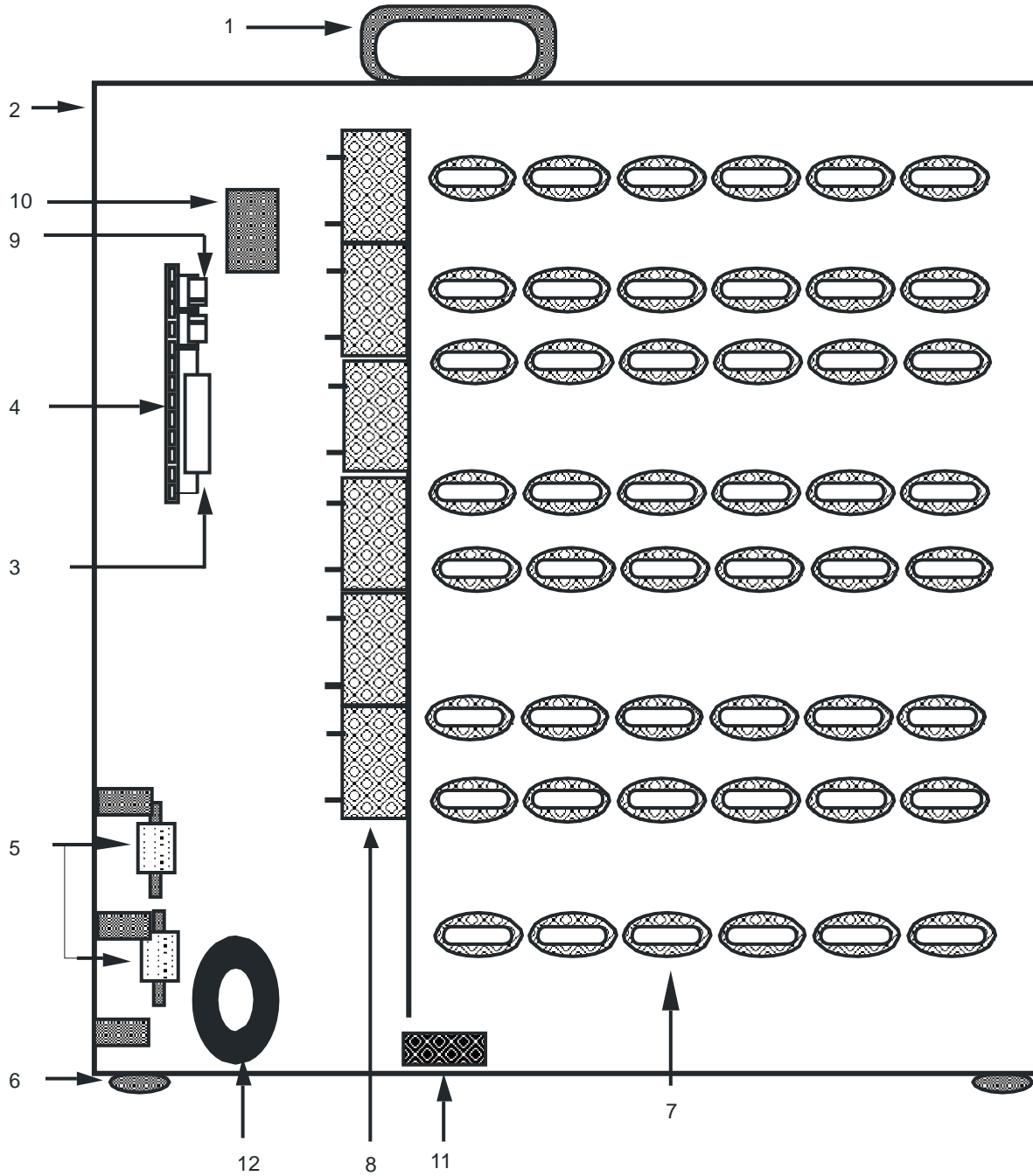

FIGURE 3 - 2

INTERIOR PARTS
FIGURE 3-2

DRAWING NUMBER	PART NUMBER	DESCRIPTION VENDOR NO.	NUMBER USED
1	HD-10	FOLDING HANDLE	1
2	BX-27D	20" X 21" X 8" ALUM BOX	1
3	RC-14	12KΩ, 11W RESISTOR	1
4	TM-13	TERMINAL STRIP 13 POS	1
5	FS-62	250 FUSE, 600V	3
6	FT-10	GLIDES	8
7	LR-25	25Ω RESISTOR	48
8	RY-35	RELAY, 24VDC, 30A, MAGNACRAFT	16
9	RD-19	200V, 5W ZENER DIODE	2
10	RY-21	RELAY, 120VAC, 2PDT, 10A MIDTEX 25862T200	1
11	SW-11	AIR FLOW SWITCH	1
12	CT-15	250:5 CURRENT TRANSFORMER	3
*	GL-20	RESISTOR GRILL	1

FAN PANEL PARTS LAYOUT

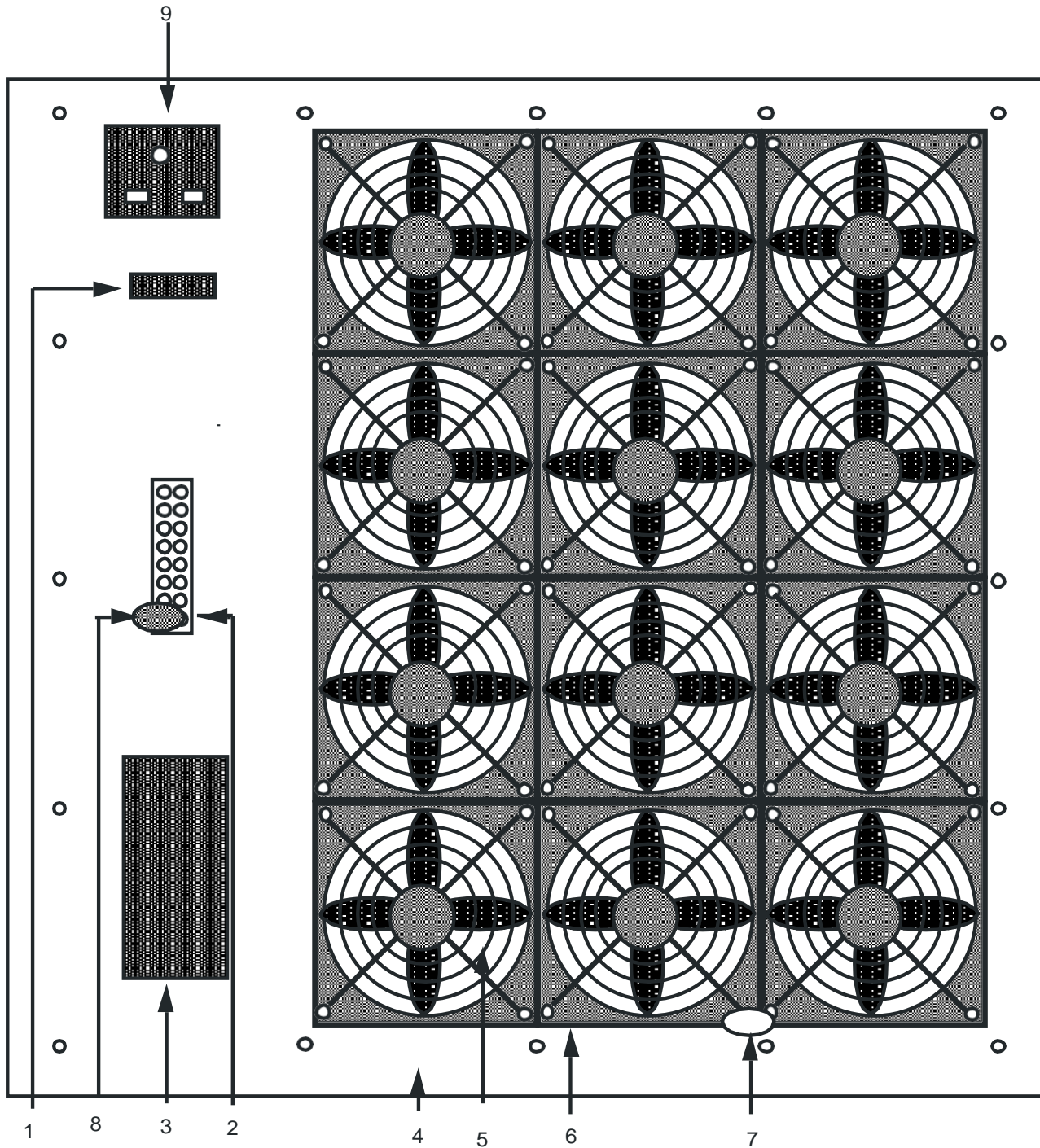

FIGURE 3 - 3

FAN PANEL PARTS
FIGURE 3-3

DRAWING NUMBER	PART NUMBER	DESCRIPTION VENDOR NO.	NUMBER USED
1	FS-11	FUSE 10A GLASS	1
2	TM-20	8 POSITION TERMINAL STRIP V-BEAU PRODUCTS (78008)	1
3	PS-30	30VDC 400W POWER SUPPLY RICHARDSON (NL3271)	1
4	FP-57	ALUM. FAN PANEL	1
5	GL-10	FAN GRILL CHROME V-MERRILL (B-22662)	12
6	FN-25	24VDC FAN EBM (W2G110-AK43-31)	12
7	TS-15	THERMAL SWITCH GEMLINE (L-155)	1
8	SW-12	TILT SWITCH	1
9	AC-12	120VAC PLUG CONNECTION	1

VENDOR LIST

The following is a list of vendors for parts shown in the parts list.

VENDOR

Anderson Power Products
145 Newton St.
Boston MA. 02135

Allied Electronics, Inc.
3425 Corporate Way, Suite A
Duluth, Ga. 30136

Bussmann Manufacturing
Distributed by Allied

Control Design Supply
1939-F Parker CT
Stone Mountain, GA. 30087

Cutler-Hammer
Distributed by Peerless

EBM Industries, Inc.
Distributed by Peerless

E.F. Johnson
Distributed by Peerless

Electric Supply Co.
433 Bishop St.
Atlanta, Ga. 30325

Gemline Products, Inc.
12472 Edison Way
Garden Grove, Ca. 92641

Merrill Manufacturing Corporation
236 South Genesee Street
Merrill, WI. 54452

Peerless Radio Corporation
3101 towercreek Pkwy, Suite 590
Atlanta, GA. 30339

Syrelec Electronics Corp.
Distributed by Control Design

Vemaline Products
333 Strawberry Field Rd.
Warwick, RI. 0288

GENERAL SERVICE

There is no regular maintenance required on the load bank. There are no adjustments inside the load bank. It should however be checked periodically for defective fans, burned out light bulbs, and defective meters.

To remove the fan panel, remove the screws around the outer edge.

The meters can be removed and replaced from the front panel.

The fan grills should be kept free of any trash.

Do not place any objects in the fan or resistor grill.

FAN REPLACEMENT

The following are steps to take to replace a defective fan.

1. Remove the screws holding the fan panel to the load bank.
2. Remove the wires on the terminal strip coming from the load bank.
3. Drill out the rivets holding the fan (four on each side).
4. Lift up the fan and unplug the wires to the fan. Connect the plug to the new fan.
5. Rivet the new fan back to the fan panel and install the fan guard.
6. Install the wires back on the terminal strip and place the fan panel back on the load bank. Make sure that the wires are on the proper terminals.

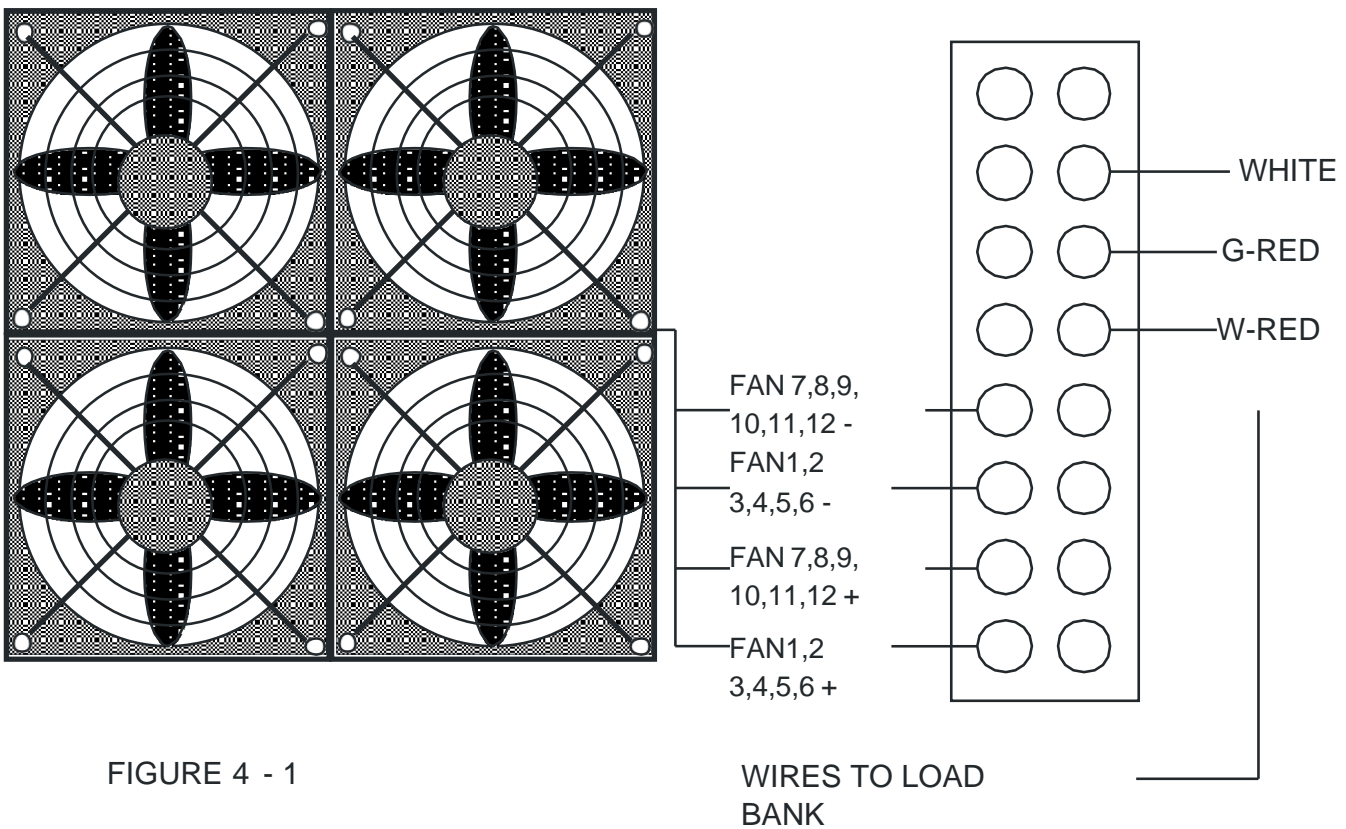
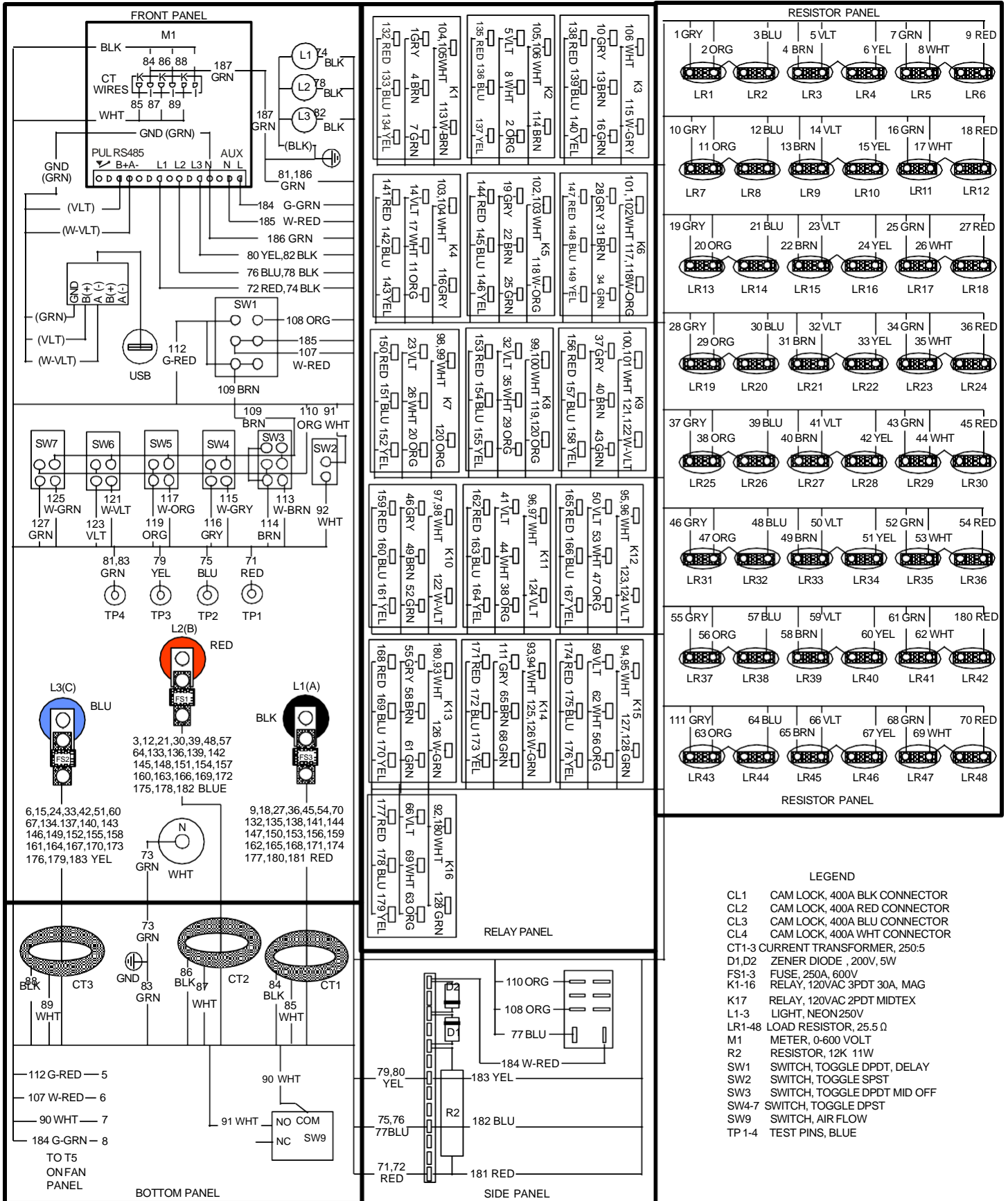

FIGURE 4 - 1

LB-60-100D INTERIOR WIRING

02/24/2017



- LEGEND**
- CL1 CAM LOCK, 400A BLK CONNECTOR
 - CL2 CAM LOCK, 400A RED CONNECTOR
 - CL3 CAM LOCK, 400A BLU CONNECTOR
 - CL4 CAM LOCK, 400A WHT CONNECTOR
 - CT1-3 CURRENT TRANSFORMER, 250:5
 - D1,D2 ZENER DIODE , 200V, 5W
 - FS1-3 FUSE, 250A, 600V
 - K1-16 RELAY, 120VAC 3PDT 30A, MAG
 - K17 RELAY, 120VAC 2PDT MIDTEX
 - L1-3 LIGHT, NEON 250V
 - LR1-48 LOAD RESISTOR, 25.5 Ω
 - M1 METER, 0-600 VOLT
 - R2 RESISTOR, 12K 11W
 - SW1 SWITCH, TOGGLE DPDT, DELAY
 - SW2 SWITCH, TOGGLE SPST
 - SW3 SWITCH, TOGGLE DPDT MID OFF
 - SW4-7 SWITCH, TOGGLE DPST
 - SW9 SWITCH, AIR FLOW
 - TP 1-4 TEST PINS, BLUE

FIGURE 5-1

FAN PANEL WIRING

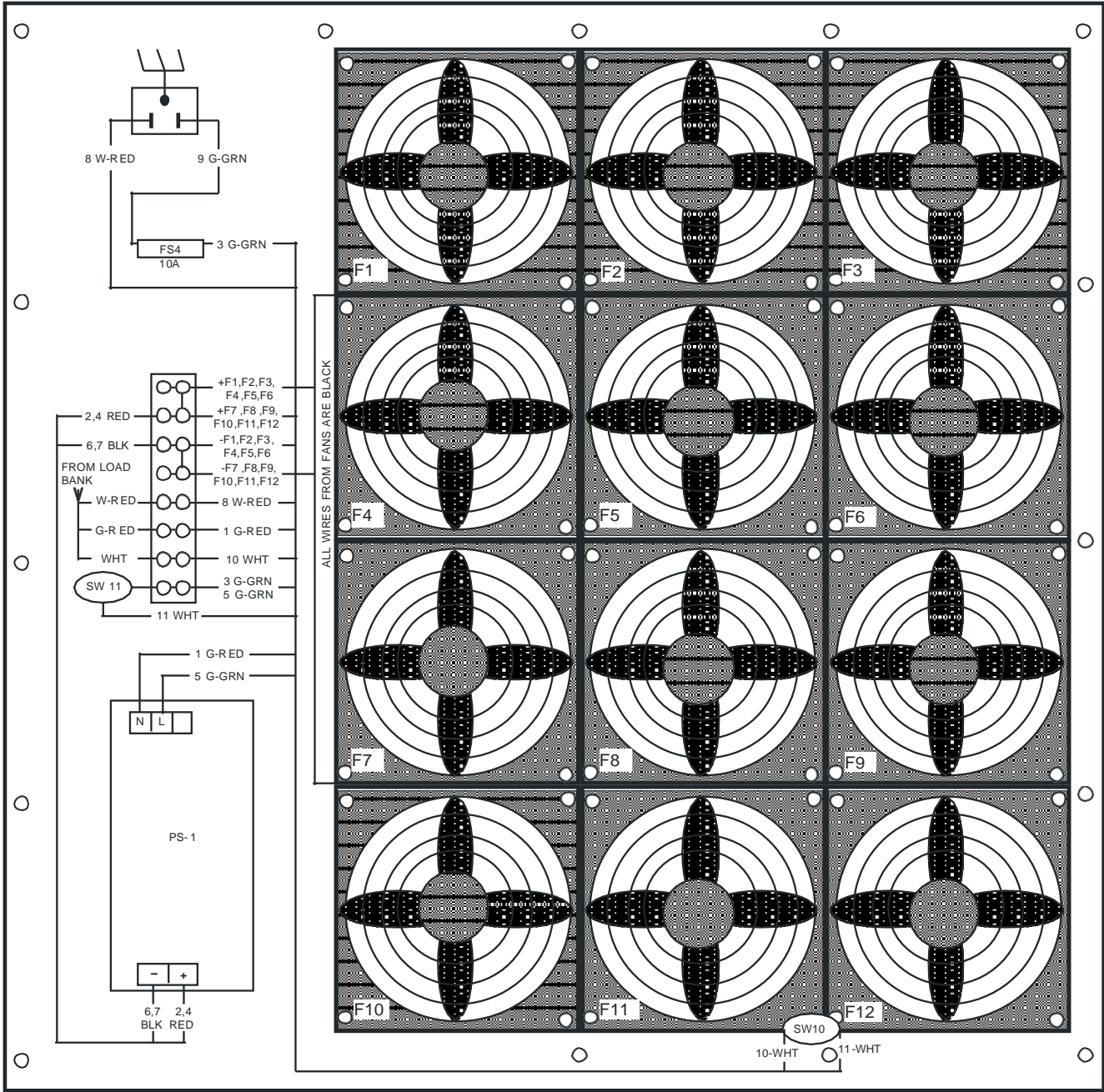

FIGURE 5 - 2

LB-60-100D SCHEMATIC

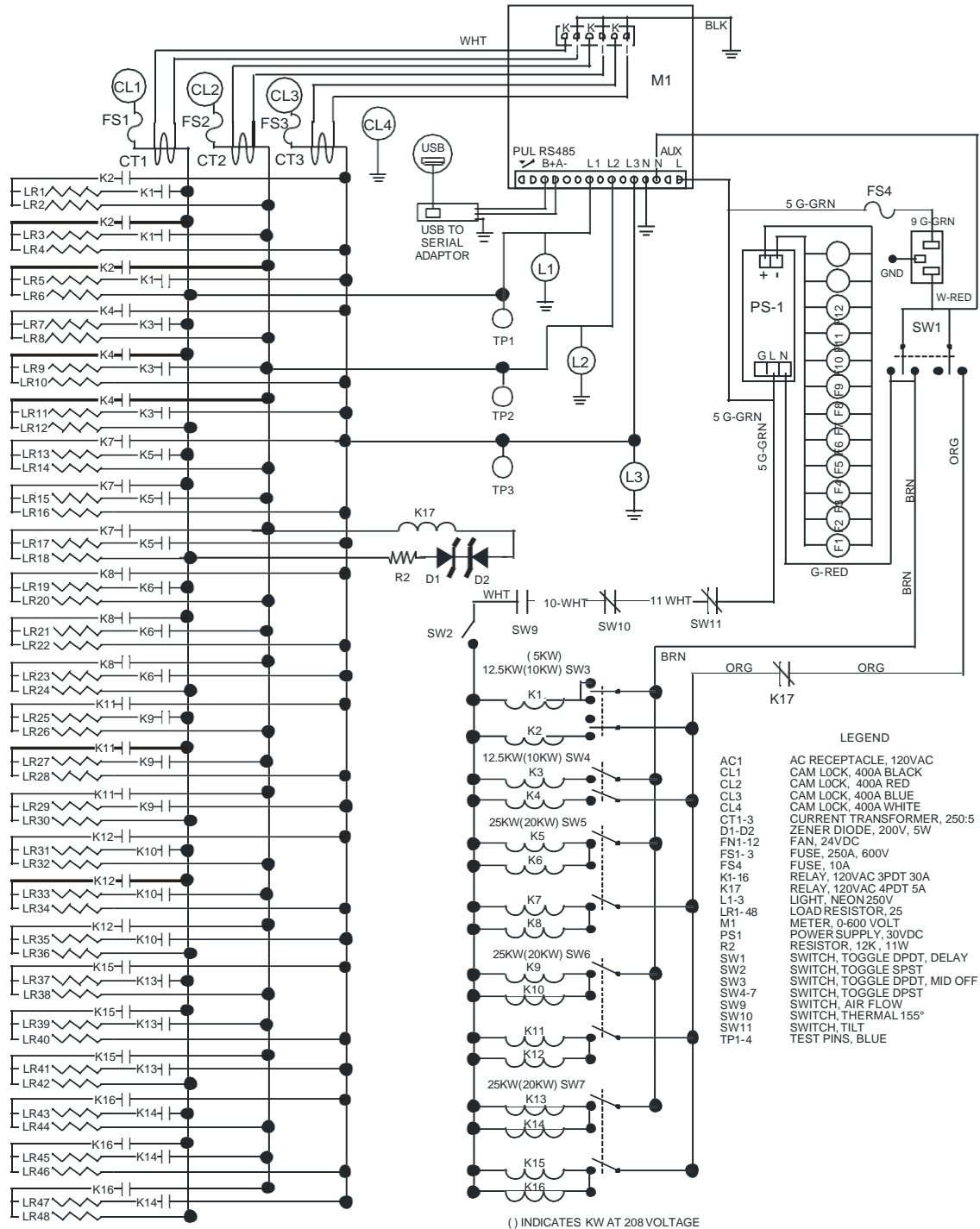

FIGURE 5-3

- LEGEND**
- AC1 AC RECEPTACLE, 120VAC
 - CL1 CAM LOCK, 400A BLACK
 - CL2 CAM LOCK, 400A RED
 - CL3 CAM LOCK, 400A BLUE
 - CL4 CAM LOCK, 400A WHITE
 - CT1-3 CURRENT TRANSFORMER, 250:5
 - D1-D2 ZENER DIODE, 200V, SW
 - FN1-12 FAN, 24VDC
 - FS1-3 FUSE, 250A, 600V
 - FS4 FUSE, 10A
 - K1-16 RELAY, 120VAC 3PDT 30A
 - K17 RELAY, 120VAC 4PDT 5A
 - L1-3 LIGHT, NEON 250V
 - LR1-48 LOAD RESISTOR, 25
 - M1 METER, 0-600 VOLT
 - PS-1 POWER SUPPLY, 30VDC
 - R2 RESISTOR, 12K, 11W
 - SW1 SWITCH, TOGGLE DPDT, DELAY
 - SW2 SWITCH, TOGGLE SPST
 - SW3 SWITCH, TOGGLE DPDT, MID OFF
 - SW4-7 SWITCH, TOGGLE DPST
 - SW9 SWITCH, AIR FLOW
 - SW10 SWITCH, THERMAL 155°
 - SW11 SWITCH, TILT
 - TP1-4 TEST PINS, BLUE