



EME SERIES ELECTROMANTLES.

INSTRUCTION BOOK

Please take your time to read this Instructions book in order to understand the safe and correct use of your new Bibby Scientific product.

It is recommended the Responsible Body for use of this equipment reads this Instruction book and ensures the user(s) are suitably trained in its operation.

Contents.

Section 1.	Introduction	Page 3
Section 2.	Symbols and using this instructions book.	Page 4
Section 3.	Safety Information.	Page 5
Section 4.	Unpack and Contents.	Page 7
Section 5.	Installation.	Page 9
Section 6.	Environmental Protection.	Page 10
Section 7.	Product Operation.	Page 11
Section 8.	Technical Specification.	Page 14
Section 9.	Maintenance	Page 17
Section 10.	Replaceable Parts and Accessories	Page 20
Section 11.	Notes	Page 21
Section 12.	Customer Support	Page 23
Section 13.	EC Declaration of Conformity.	Page 24
Appendix A		Page 22

© The copyright of this instruction book is the property of Bibby Scientific Limited. This instruction book is supplied by Bibby Scientific Limited on the express understanding that it is to be used solely for the purpose for which it is supplied. It may not be copied, used or disclosed to others in whole or part for any purpose except as authorised in writing by Bibby Scientific Limited. Bibby Scientific Limited reserves the right to alter, change or modify this document without prior notification.

In the interest of continued development Bibby Scientific Limited reserve the right to alter or modify the design and /or assembly process of their products without prior notification.

This product is manufactured in Great Britain by Electrothermal, part of the Bibby Scientific Group of companies.

Bibby Scientific Limited.
Beacon Road,
Stone,
Staffordshire ST15 0SA,
Great Britain.

Tel: +44(0)1785 812121
Fax: +44(0)1785 810405

1. INTRODUCTION.

- 1.1. The Bibby Scientific series of heating mantles has been specifically designed to provide a comprehensive answer to heating fluids in round bottomed glassware in the modern laboratory. It combines the traditional Bibby Scientific heating elements with many new features thus providing the user with several options to meet different applications.
- 1.2. Heating control is provided by a built-in solid state energy regulator.
- 1.3. The enclosures of EME's are housed in aluminium cases with a paint finish to give good chemical resistance while the top cover is made from Polypropylene.
- 1.4. The products are provided with ventilation slots underneath and around the rim to ensure a low enclosure surface temperature. The heating element is retained in thermal Rockwool to create a heating cartridge that facilitates very easy replacement in the event of any damage. All EME's are supplied with support rods and clamps.
- 1.5. Electrothermal offers a comprehensive mantle range with the Standard cool-to-touch vented case with element temperatures between ambient and 450 deg C.
- 1.6. EME Mantles are provided with the option of three or six recesses, built in solid-state energy controllers and choice of heater or heater/stirrer combinations. Capacities for flasks range from 100ml to 1000ml. All Extraction Mantles have individual energy regulator with indicator light for each heater cartridge position, allowing liquids with different boiling points to be heated alongside each other. The robust construction permits continuous operation of the units as required by routine extraction tests.

2. SYMBOLS AND USING THIS INSTRUCTION BOOK

2.1. Throughout this Instruction book the following symbols are shown to identify conditions which pose a hazard to the user, or to identify actions that should be observed. These symbols are also shown on the product, or its packaging. When a symbol is shown next to a paragraph or statement it is recommended the user takes particular note of that instruction in order to prevent damage to the equipment or to prevent injury to one's self or other people.

The Responsible Body and the Operator should read and be familiar with this Instruction book in order preserve the protection afforded by the equipment.

To prevent injury or equipment damage it is the manufacturers recommendation that all persons using this equipment are suitably trained before use.

2.2. Symbols defined.



Caution, risk of danger. See note or adjacent symbol.



Protective conductor terminal to be earthed.
(Do not loosen or disconnect).



Caution / risk of electric shock



Recyclable Packing Material.



Do not dispose of product in normal domestic waste.



Caution. Hot surface.



Refer to Instructions book



This symbol adjacent to an indication lamp means mains power Off/On when lamp non-illuminated / illuminated



This symbol adjacent to a switch denotes the Off condition for mains power.



This symbol adjacent to a switch denotes the ON condition for mains power.



This symbol adjacent to a switch denotes the Off condition for the Heater or Stirrer.



This symbol adjacent to a switch denotes the On condition for a Heater or Stirrer.



This symbol denotes stirrer speed control.



Bio Chemical Hazard. Caution required. Will require decontamination.



Material irritant to skin. When handling wear face mask to BS/EN 149 and protective gloves

 **HOT ZONES, AVOID CONTACT**

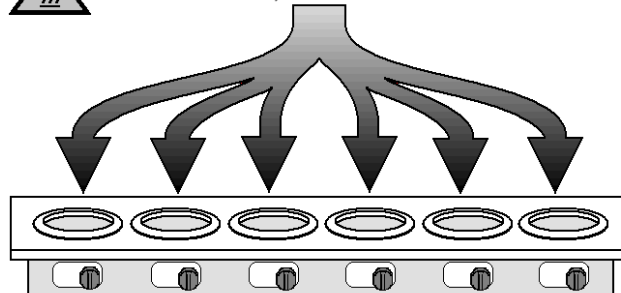

Hot Zone on product EME, EMEA.

3. SAFETY INFORMATION.

This product has been designed for safe operation when used as detailed in accordance with the Manufacturers instructions.

NOTE: Failure to use this equipment in accordance with the manufactures instruction book may compromise your basic safety protection afforded by the equipment and may invalidate the warranty / guarantee. The warranty / guarantee does not cover damaged caused by faulty installation or misuse of the equipment

3.1. Prevention of Fire and Electric Shock.



To prevent a risk of fire or electric shock, **DO NOT** open your *product* case without authorisation. Only qualified Service personnel should attempt to repair this product.



Replace fuses only with the type as listed in section, 'Technical Specifications and Parts and Accessories' (See fuse type and rating).



Ensure the Mains Power Supply conforms to rating found on the data plate located on the back of this product.



Never Operate this equipment without connection to earth / ground. Ensure the mains supply voltage is correctly earthed / grounded in accordance with current area legislation.

3.2. General Safe Operating Practice.



Always follow good laboratory practice when using this equipment. Give due recognition to your company's safety and legislative health & safety procedures and all associated legislation applicable to your areas of operation. Check laboratory procedures for substances being heated and ensure all hazards (e.g. explosion, implosion or the release of toxic or flammable gases) that might arise have been suitably addressed before proceeding. When heating certain substances the liberation of hazardous gases may require the use of a fume cupboard or other means of extraction.



Ensure equipment is used on a clean, dry, non-combustible, solid work surface with at least 300mm suitable clearance all around from other equipment.



Do not position the product so that it is difficult to disconnect from the mains supply.



Do not touch the heating element or any glass vessel whilst in use.



Do not lean or stretch over equipment, glassware and fixings when in use.



Do not immerse unit in water or fluids.



Do not spill substances onto the mantle. If spillage does occur, disconnect unit from mains supply and follow instructions as detailed in Maintenance. (Section 9).



Do not cover the mantle whilst in use. **Do not** block or obstruct ventilation slots / airways.



Do not leave equipment switched on without a charged flask(s).



Do not thermally insulate the exposed upper section of the vessel(s), as the insulation used may obstruct the convection cooling airways around the rim of the cartridge enclosure and cause the mantle to overheat.



It is not recommended to leave any heating apparatus unattended during operation.



Only use Original Equipment manufactures spares and accessories. Ref Section 10.



Stirring versions of this equipment generate magnet fields. Keep all metal objects and magnetic data devices (e.g. credit cards) away from the stirrer unit.



The equipment is not spark, flame or explosion proof and has not been designed for use in hazardous areas in terms of BSEN 60079-14:1997. Keep flammable, low flash point substances away from the apparatus.



Do not operate or handle any part of the product with wet hands.



Keep the Mains cord and moulded IEC plug and lead set away from the heating surface.

4. UNPACKING AND CONTENTS.

4.1. Product Identification:

A Catalogue number allocated to each type of mantle is descriptive. The method of coding is detailed below.

First and second Characters	EME Series
Next Character	'A' unit with stir facility.
Next Character (if Multi bank)	3 or 6 = 3 way or 6 way.
Next four Characters	Flask size in ml. 0050, 0100, 0500, 1000,
Next Character after the /	'C' Controlled.
Next Character	'E' Earthed screen.
Last Characters	No Characters = 230V, X1 = 115V,

The following family tree outlines product variants.

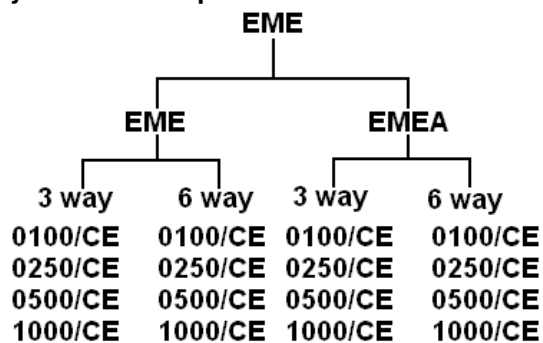

Please check the contents of your carton against the relevant product diagram.
Applicable to all EME product.

Item No	Description	Qty
1	EME product (6 way shown).	1
2	Mains cord and moulded IEC plug and lead set. <i>(May differ from illustration depending on variant).</i>	A/R
3	Support rods set. (2 of one length and one of another).	1
4	Stir bars (bag of 3 or 6) (EMEA Only) .	1
5	Instructions book	1
6	Support rod clamps (packet).	1

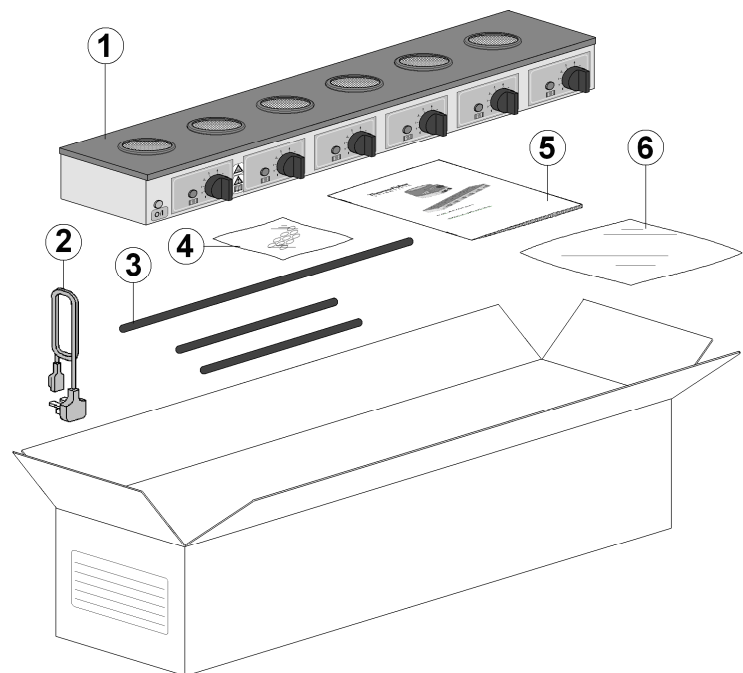

	<i>Serial Number</i>	<i>Unit Model/Cat Number</i>
For future reference please record your products Serial and Model Numbers.		

5. INSTALLATION.

5.1. Electrical safety and installation.

5.1.1. This equipment is designed to be used safely under the following conditions:-

- Indoor use.
- Altitude up to 2000 meters.
- Temperatures between 5°C and 40°C.
- Maximum relative humidity 80% for temperatures up to 31°C decreasing linearly to 50% relative humidity at 40°C.
- Mains supply voltage fluctuations up to $\pm 10\%$ of the nominal voltage.
- Transient overvoltages typically present on the mains supply. Overvoltage category II
- Applicable rated pollution degree 2.



5.1.2. This equipment must be earthed / grounded to a fixed earth / grounded mains socket outlet. The mains supply is to earthed / grounded in accordance with current legislation. See Technical Specification for recommended fuse ratings.

5.1.3. Ensure only the correct rated mains input fuses are fitted. (Where applicable ensure the correct Mains cord and moulded IEC plug and lead set fuse if fitted). See Technical Information Section 8 of this Instructions book.

5.1.4. Check the voltage on the product data label on this product unit and those of any accompanying electrical accessory. Ensure the rating conforms to your local supply.

5.1.5. This product should be connected to a mains supply source which incorporates a RCD or GFCI device that has a tripping current of 30mA or less. The RCD or GFCI residual Current Device cuts off power to the equipment immediately it detects a current leakage fault. For example, cutting off the power when there is an accidental liquid spillage in a mantle protected with an earth (ground) screen.



5.1.6. Do not install this product or accessories on a surface which may become flooded.

5.1.7. The unit is supplied with a Mains cord and moulded IEC plug and lead set wired as follows.



Green / Yellow	or	Green	=	Earth / Ground
Blue	or	White	=	Neutral
Brown	or	Black	=	Live / line hot.

5.2. **Observation:** the surface of the heating element of a mantle cartridge will upon receipt look slightly discoloured. This discolouration is normal and occurs at the factory during test when the mantle is first heated up.

USA Notification.

Warning! Any modification or changes made to this device, unless explicitly approved by Electrothermal Engineering Limited, will invalidate the authorisation of this device. Operation of an unauthorised device is prohibited under Section 302 of the Communications Act of 1934 as amended, and Subpart 1 of Part 2 of Chapter 47 of the code of Federal Regulations.

Note: This equipment has been tested and found to comply with the limits for a Class B digital device, pursuant to part 15 of the FCC Rules. These limits are designed to provide reasonable protection against harmful interference in a residential installation. This equipment generates, uses and can radiate radio frequency energy and, if not installed and used in accordance with the instructions, may cause harmful interference to radio communications. However, there is no guarantee that interference will not occur in a particular installation. If this equipment does cause harmful interference to radio or television reception, which can be determined by turning the equipment off and on, the user is encouraged to try to correct the interference by one or more of the following measures:

- Reorient or relocate the receiving antenna.
- Increase the separation between the equipment and receiver.
- Connect the equipment into an outlet on a circuit different from that to which the receiver is connected.
- Consult the dealer or an experienced radio/TV technician for help.

6. ENVIRONMENTAL PROTECTION.

6.1. Maximum consideration has been given to environmental issues within the design and manufacturing process without compromising end product performance and value.



6.2. Packaging materials have been selected such that they may be sorted for recycling.



6.3. At the end of your product and accessories life, it must **not** be discarded as domestic waste. Ref: EU Directive 2002/96/EC on Waste Electrical and Electronic Equipment Directive (WEEE). Please contact your distributor / supplier for further information. For end users outside of the EU consult applicable regulations.

6.4. This product should only be dismantled for recycling by an authorised recycling company.



This product and accessories must be accompanied by a completed Decontamination Certificate prior to any disposal. Copies of the Certificate are available from your distributor of Bibby Scientific products, or you may copy and enlarge from 'Appendix A' of this instruction book.

Bibby Scientific's Electrothermal branded product range is registered with the Environment Agency under the name of as Electrothermal Engineering Limited as being a producer of WEEE (Waste Electronic and Electrical Equipment) through b2b Compliance, an authorised waste collection compliance scheme.

7. PRODUCT OPERATION.

7.1. EME 3 and 6-way.

7.1.1. Overview of EME Mantle.

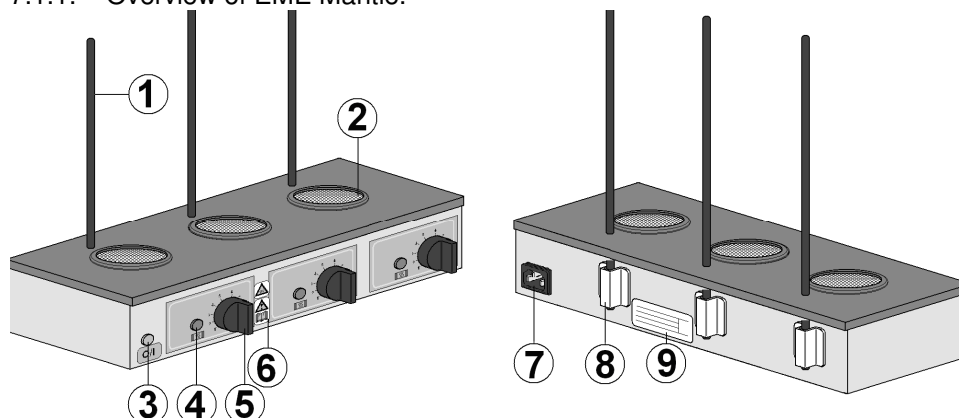

Item	Description.
1	Support Rods. (NB for 6 way units the support rod arrangement is as per EMEA6 way).
2	Heating Element 
3	Mains power on indicator
4	Heating element on
5	Energy regulator control knob
6	Warning Labels. (Hot surface and refer to this Instruction book).
7	Mains input IEC socket (Contains protective fuses).
8	Rod support brackets
9	Data Plate

7.1.2. Fasten the rod supports provided into the mantle's rod support location bracket via the top cover holes.

7.1.3. With the mains supply electricity switch off, Connect the mains cord and moulded IEC plug and lead set to the mains IEC socket.

7.1.4. Place a charged, clean, dry glass vessel of the size indicated on the mantle data plate label in the positions intended for use. Wherever possible the glass vessel should be supported within the mantle by means of the support rod and clamp.

7.1.5. Switch on the mains electrical supply. Adjust the controller regulator knob in each position to the required setting.

NOTE: The mains power on indication neon will illuminate. The amber heating on neon will illuminated in each position and pulsate (depending on setting) when the heaters are in operation.

7.1.6. When the process is complete switch the regulator knobs to their off positions. Disconnect the mains electricity supply.

7.1.7.  Remove charged vessels. Handle hot charged vessel with care.

7.2. EMEA 3 and 6-way.

7.2.1. Overview of EMEA Mantle.

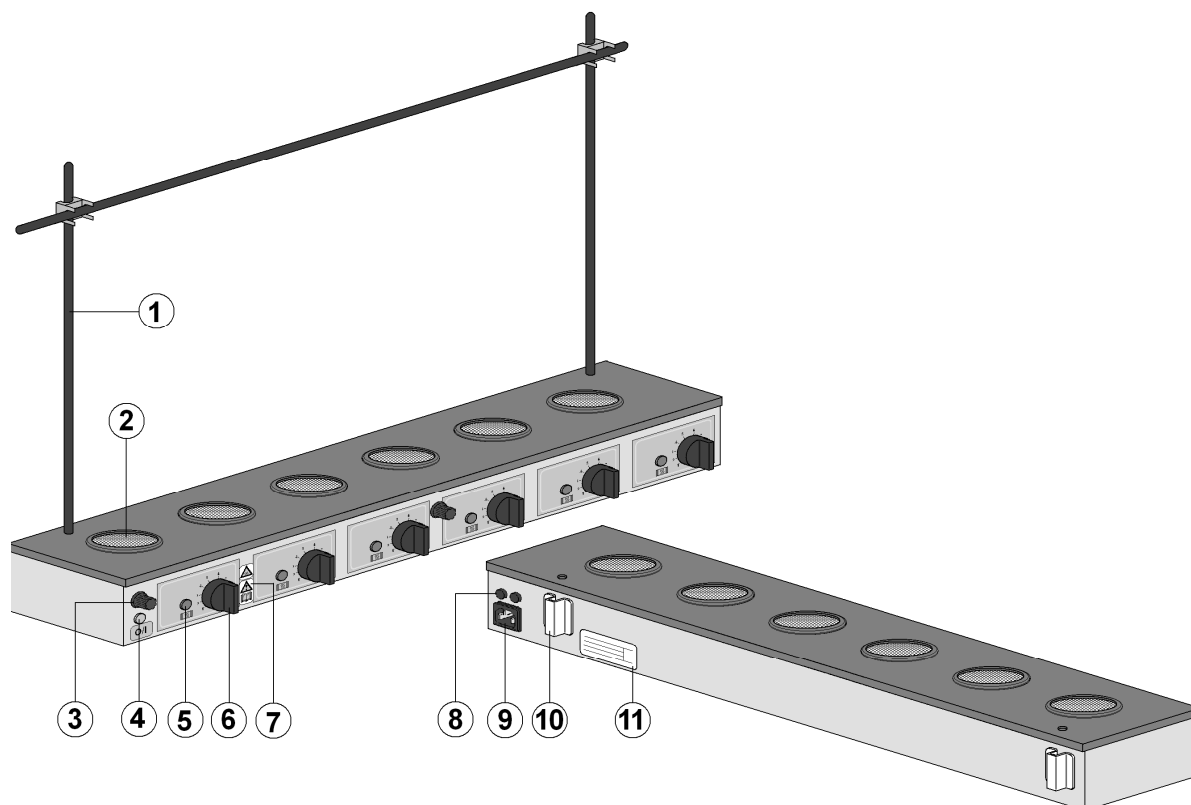

7.2.2. Switch on the mains electrical supply. Adjust the controller regulator knob in each position to the required setting.

NOTE: The mains power on indication neon will illuminate. The amber heating on neon will illuminated in each position when the heaters are in operation.

Item	Description.
1	Support Rods and clamps (<i>NB for 3 way units the support rod arrangement is as per EME3 way.</i>)
2	Heating Element 
3	Stir speed regulation
4	Mains power on indicator
5	Heating element on
6	Energy regulator control knob
7	Warning Labels. <i>(Hot surface and refer to Instructions book).</i>
8	Fuse holders (<i>Contains protective fuses.</i>)
9	Mains input IEC socket
10	Rod support brackets
11	Data Plate

- 7.2.3. Fasten the rod supports provided into the mantle's rod support location bracket via the top cover holes and fit the cross bar using the clamps supplied.
- 7.2.4. With the mains supply electricity switch off, Connect the mains cord and moulded IEC plug and leads set to the mains IEC socket.
- 7.2.5. Carefully place the stir bars provided into each vessel and turn the rotational speed controls to the OFF (O – setting).
- 7.2.6. Place a charged, clean, dry glass vessel of the size indicated on the mantle data plate label containing the stirrer bars in the positions intended for use. Wherever possible the glass vessel should be supported within the mantle by means of the support rod and clamp.
- 7.2.7. Switch on the mains electrical supply. Adjust the controller regulator knob in each position to the required setting.

NOTE: The mains power on indication neon will illuminate. The amber heating on neon will illuminate (and pulsate dependent on setting) in each position when the heaters are in operation.

- 7.2.8. A single stirring module controls the stirring on the EMEA3. Two separate stirrer modules and two controllers are used on the EMEA6. Each controller controlling the stir function on the three mantle positions immediately to the right of the respective control position.

Uni-directional stirring up to 800 RPM.

- 7.2.9. Switch the stir facility on. The neon will illuminate.
- 7.2.10. Adjust the rotational speed by means of the speed control knob. Should the stirring action be lost by over rotation, then reduce the stir speed to minimum, wait for the stir bar to come to rest and slowly re-increase the stir speed once more.
- 7.2.11. When the process is complete switch the regulator knobs to their off positions. Disconnect the mains electricity supply.

- 7.2.12.   Remove charged vessels. Handle hot charged vessel with care.

8. TECHNICAL SPECIFICATION.

8.1. Specifications EME range (General).

Mains input supply voltage (115V-AC).	115V – AC \pm 10% at 50/60Hz.
Mains input supply voltage (230V – AC).	230V – AC \pm 10% at 50/60Hz.
Fuse type (EME-3, EMEA-3)	20mm x 5mm Glass Quick blow (F).
Fuse type (EME- 6, EMEA-6)	32mm x 6mm Glass Quick blow (F).
Operational climatic conditions.	Temperature range 5°C to 40°C. Humidity no to exceed 80%.
Heating Element Construction.	Thermal insulated element wire stitched into a cartridge construction.
Maximum Element temperature.	450°C. Nominal Max
Case construction.	Polypropylene and coated aluminium.
Thermal Insulation	Mineral Wool.
Clamps for support rods.	½" (12.7mm) dia max.

Moulded IEC lead set EME6 and EMEA6 except EMEA6 0500/CEX1, EMEA6 1000/CEX1, EME6 0500/CEX1, EME6 1000/CEX1

Mains cord and moulded IEC plug and lead set cable (UK) 13A BS1362 AZ9165	3 core earthed / ground. 2 meters long Moulded IEC plug and Lead set – supply cord H05 V V-F- Replace only with equivalent cable.
Mains cord and moulded IEC plug and lead set cable (Europe) AZ6747	3 core earthed / ground. 2 meters long Moulded IEC plug and Lead set – supply cord H05 V V-F- Replace only with equivalent cable.
Mains cord and moulded IEC plug and lead set cable (USA) AZ6746	3 core earthed / ground. 2 meters long Moulded IEC plug and Lead set – supply cord SJT VW 1- 105° Replace only with equivalent cable.
Mains cord and moulded IEC plug and lead set cable (Switzerland) AZ6175	3 core earthed / ground. 2 meters long Moulded IEC plug and Lead set – supply cord W W 05 VAS-F- Replace only with equivalent cable.
Mains cord and moulded IEC plug and lead set cable (Australia) M7079	3 core earthed / ground. 2 meters long Moulded IEC plug and Lead set – supply cord H05 V V-F Replace only with equivalent cable.
Lead set plug fuse (UK – only) AZ9165	10A

IEC lead set for EMEA6 0500/CEX1, EMEA6 1000/CEX1, EME6 0500/CEX1, EME6 1000/CEX1

20A Mains cord and IEC plug and lead set. (USA) – AZ4222	3 core earthed / ground. 2 meters long Moulded IEC plug and Lead set – supply cord SJT V W 1 105° Replace only with equivalent cable.
---	--

8.1.1. Power consumption and fuse rating.

Type	Size	Total Heating Power (Watts).		Fuse rating (Amps)	
		230V~	115V~	230V~	115V~
EME3	100ml	3x60	3x72	F3.15	F3.15
EMEA3	100ml	3x60+40(Stir)	3x72+40 (Stir)	F3.15	F3.15
EME3	250ml	3x150	3x150	F3.15	F5
EMEA3	250ml	3x150+40(Stir)	3x150+40(Stir)	F3.15	F6.3
EME3	500ml	3x200	3x200	F3.15	F6.3
EMEA3	500ml	3x200+40(Stir)	3x200+40(Stir)	F6.3	F6.3
EME3	1000ml	3x300	3x300	F5	F10
EMEA3	1000ml	3x300+40(Stir)	3x300+40(Stir)	F6.3	F10
EME6	100ml	6x60	6x72	F3.15	F5
EMEA6	100ml	6x60+80(Stir)	6x72+80(Stir)	F3.15	F6.3
EME6	250ml	6x150	6x150	F5	F10
EMEA6	250ml	6x150+80(Stir)	6x150+80(Stir)	F6.3	F10
EME6	500ml	6x200	6x200	F6.5	F15
EMEA6	500ml	6x200+80(Stir)	6x200+80(Stir)	F6.3	F15
EME6	1000ml	6x300	6x300	F10	2xF10
EMEA6	1000ml	6x300+80(Stir)	-	F10	-

8.1.2. The Ingress protection rating for the EM product range is IPX0.

8.1.3. Dimensions and weight (unpacked).

EMEx3, EMEA3 100ml

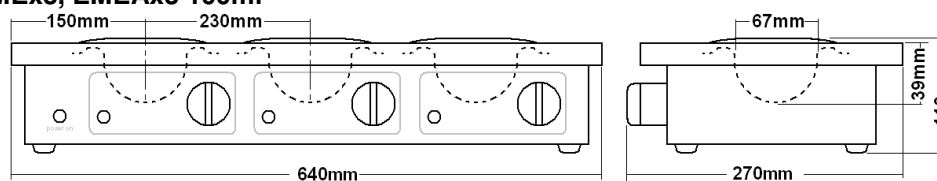

EME3/0100/CE, EMEA3/0100/CE
WEIGHT 6.2Kg

EMEx3, EMEA3 250ml

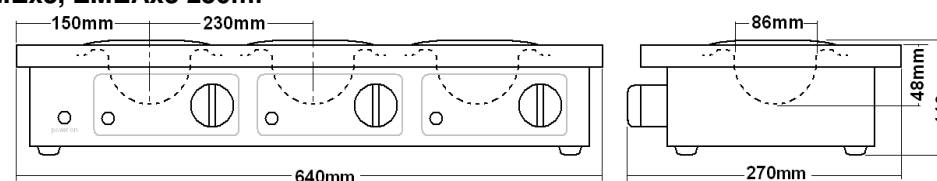

EME3/0250/CE, EMEA3/0250/CE
WEIGHT 6.2Kg

EMEx3, EMEA3 500ml

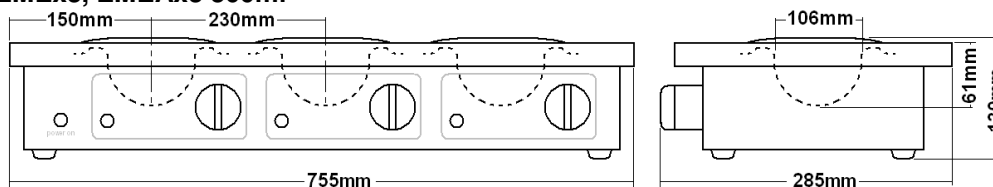

EME3/0500/CE, EMEA3/0500/CE
WEIGHT 7.4Kg

EMEx3, EMEAx3 1000ml

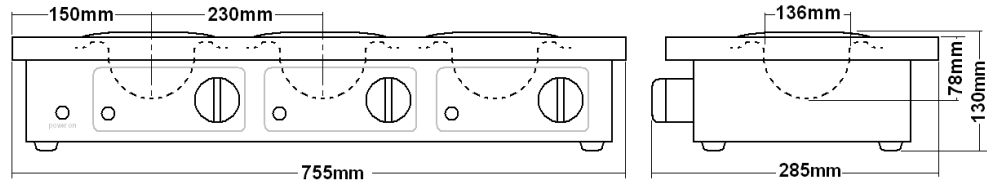

EME3/1000/CE, EMEA3/1000/CE

WEIGHT 7.4Kg

EMEx6, EMEAx6 0100ml

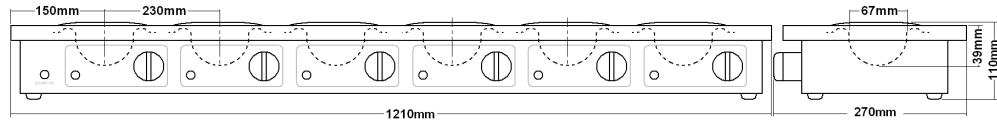

EME6/0100/CE, EMEA6/0100/CE

WEIGHT 10.1Kg

EMEx6, EMEAx6 250ml

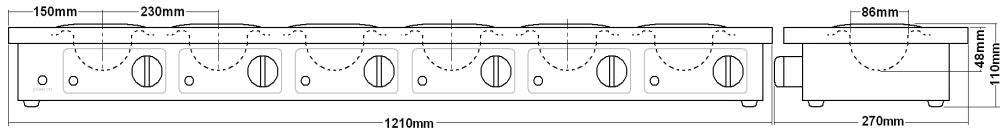

EME6/0250/CE, EMEA6/0250/CE

WEIGHT 10.1Kg

EMEx6, EMEAx6 500ml

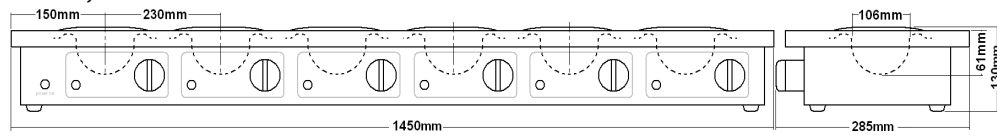

EME6/0500/CE, EMEA6/0500/CE

WEIGHT 12.5Kg

EMEx6, EMEAx6 1000ml

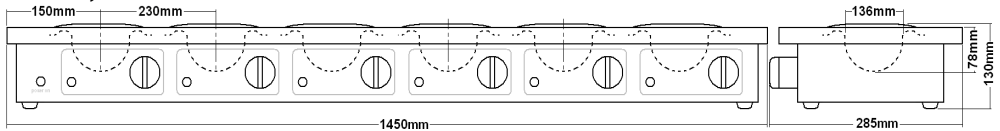

EME6/1000/CE, EMEA6/1000/CE

WEIGHT 12.5Kg

9. MAINTENANCE.

9.1. General Information.



Unplug the unit from the mains voltage supply and allow it to cool before undertaking any maintenance tasks.



Maintenance should only be carried out under the direction of the Responsible Body, by a competent electrician. Failure to do so may result in damage to the product and in extreme cases be a danger to the end user.

With proper care in operation this equipment has been designed to give many years of reliable service. Contamination or general misuse will reduce the effective life of this product and may cause a hazard.

Maintenance for the unit should include:

- Periodic electrical safety testing (an annual test is recommended as the minimum requirement).
- Regular inspection for damage with particular attention to the mains lead and plug set.
- Routine cleaning of the equipment should be undertaken using a clean cloth.

DO NOT USE SOLVENTS FOR CLEANING ANY PART OF THIS EQUIPMENT.

9.2. Fuse Replacement.

The mains fuse holder is located at rear your product. Refer to Technical specification, 'Fuse Rating' for correct fuse type and rating. Turn your product off and disconnect it from the mains supply.

EME6-way Mantle: ① Unscrew both fuse holder caps from the fuse housings and ② remove the fuses. Fit replacement fuses of the correct rate and value.

EME3 –way Mantle: Open the draw of the IEC mains electrical input socket. Remove fuses and fit replacement fuses of the correct rate and value.

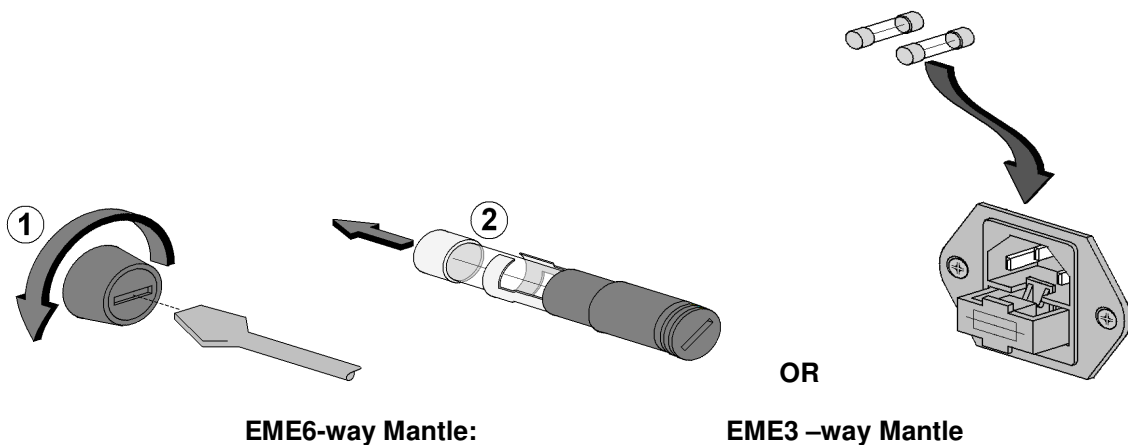

9.2.1. Heater Cartridge replacement.



IRRITANT

EME and EMEA mantles contain Rockwool mineral insulation. When handling a suitable face mask which bears the CE mark should be used. A face mask to BS/EN 149 is adequate. When handling, wear gloves. Should skin irritation be experienced it can be lessened by rinsing hands under cold running water before washing. For further information refer to guidance note EH46 published by HMSO and technical data sheets available from Rockwool Limited. Pencoed. Bridgend. CF35 6NY.

In the event of a heater element becoming damaged or open circuit the following procedure should be adopted for its replacement.

EME and EMEA

- 9.2.1.1. Unplug or disconnect the mantle from the mains electricity supply.
- 9.2.1.2. Remove the cross-head fixing screws from the lid and lift the lid off.
- 9.2.1.3. **EME / EMEA**, Disconnect the lid to base earth wire.
- 9.2.1.4. Remove the three M3 cartridge retention nuts and disconnect the cold leads from the temperature controller PCB.
- 9.2.1.5. Reverse this process to fit the new cartridge assembly. On EMEA product ensure the cold leads do not obstruct the stir belt.
- 9.2.1.6. Replace the earth lead and base and refasten using the previously removed cross-head fixing screws.
- 9.2.1.7. The responsible body shall check the electrical safety of the product before further use.

9.3. Spillage and Decontamination.

Spillage:

In the event of spillage or glassware fracture, do not touch the mantle. Disconnect the product from the mains electrical supply. Allow the product to cool. Wearing suitable hand protection (giving due consideration to substances that were being heated) carefully remove any pieces of broken glassware. If decontamination is necessary, see section below. Otherwise wipe off all excess liquid from the mantle and surrounding area using an absorbent soft cloth. Drain of any residual fluid retained in the mantle. In the case of excessive spillage/ flask fracture, invert the mantle and allow it to drain for minimum of one hour. Then proceed with the following drying out procedure. Place the complete mantle, the correct way up, in a heated oven at 50 °C for a minimum period of 40 hours

! Warning: The equipment cannot be assumed to meet all the safety requirements of EN 61010-2-010: 2003 during the drying out process and until the drying out process is completed.

If in doubt please consult Customer Support. Refer to section 11.” NB: Replacement heater cartridges are obtainable from your Distributor/Manufacturer.



Before further use, the mantle must be subjected to electrical safety testing by competent service personnel.

If in doubt please consult Customer Support. Refer to section 11.



If the equipment has been exposed to contamination, the Responsible Body is responsible for carrying out appropriate decontamination. If hazardous material has been spilt on or inside the equipment, decontamination should only be undertaken under the control of the Responsible Body with due recognition of possible hazards. Before using any cleaning or decontamination method, the Responsible Body should check with the manufacturer the proposed method will not damage the equipment.

Prior to further use, the Responsible Body shall check the electrical safety of the unit. Only if all safety requirements are met can the unit be used again. The above procedure is intended as a guide. Should spillage occur with a toxic or hazardous fluid then special precautions may be necessary.

Decontamination Certificate.

Note: In the event of this equipment or any part of the unit becoming damaged, or requiring service, the item(s) should be returned to the manufacturer for repair accompanied by a decontamination certificate. **Copies of the Certificate are available from Distributor/Manufacturer. Appendix A of this instructions book may be copied and enlarged.**

At the end of life, this product must be accompanied by a Decontamination Certificate. See section 6.3 and 6.4

10. PARTS AND ACCESSORIES

10.1. Replacement Heater Cartridges. All Electrothermal mantles are specified by the letters RE and Flask size. Add x1 suffix when ordering for 115V

Mantle model type		Replacement heater Cartridge.
EME0100/CEB (3 & 6 way).	Order	REME0100
EME0250/CEB.(3 & 6 way).	Order	REME0250
EME0500/CEB.(3 & 6 way).	Order	REME0500
EME1000/CEB. (3 & 6 way).	Order	REME1000
EMEA0100/CE (3 & 6 way)	Order	REMEA0100
EMEA0250/CE (3 & 6 way)	Order	REMEA0250
EMEA0500/CE (3 & 6 way)	Order	REMEA0500
EMEA1000/CE (3 & 6 way)	Order	REMEA1000

10.2. Replaceable parts.

Order Number	Description.	Quantity
AZ9165	Mains cord and moulded IEC plug and lead set (UK) 230V-AC	1
AZS4222	Mains cord and moulded IEC plug and lead set (USA) 115V-AC – (<i>EMEA6 0500/CEBx1, EME6 1000/CEBx1, EMEA6 0500/CEx1, EMEA6 1000/CEx1</i>).	1
AZ6746	Mains cord and moulded IEC plug and lead set (USA) 115V-AC	1
AZ6747	Mains cord and moulded IEC plug and lead set (Europe) 230V-AC	1
AZ9021	Solid state Simmerstat assembly (90 -250V-AC).	1
AZ9033	Fuse: F15A	10
AZ9034	Fuse: F10A	10
AZ9035	Fuse: F8A	10
AZ9036	Fuse: F6.3A	10
AZ9038	Fuse: F0.5A	10
AZ9040	Fuse:F2.5A	10
AZ9041	Fuse: F3.15A	10
AZ9065	Fuse: F12.5A	10
M5607	Neon: Clear (230V)	1
M5608	Neon: Amber (230V)	1
M5619	Neon: Clear (115V)	1
M5620	Neon: Amber (115V)	1
129320/3	Support rod (710mm / 28 “ long).	1
129320/4	Support rod (1160mm / 45” long).	1
129320/5	Support rod (1440mm / 55” long).	1
129320/6	Support rod (590mm / 23” long).	1

APPENDIX 'A'. DECONTAMINATION CERTIFICATE.

Bibby Scientific Limited. Beacon Road, Stone, Staffordshire ST15 0SA. Great Britain Tel: +44(0)1785 812121. Fax: +44(0)1785 810405 E-mail: electrothermalhelp@bibby-scientific.com		
<u>DECONTAMINATION CLEARANCE CERTIFICATE</u>		
For the Inspection, Repair or Return of Medical, Laboratory or Industrial Equipment.		
Prior to a Service Engineer working on equipment that has been in an environment where substances hazardous to health may have been used, you are requested to provide the following information:		
CUSTOMER DETAILS		
Company:-	Address:-	
Department:-		
Contact Name:-		
Tel No:-	Post Code:-	
Fax No:-		
<u>Product Description</u>		
Model No:-	Serial No:-	
Has the equipment been exposed to any of the following. Please answer all questions by deleting YES/NO as applicable and by providing details in section 2 below.		
A. Blood, body fluids, Pathological specimens	YES/NO	Provide details if YES
B. Biodegradable material that could become a hazard	YES/NO	Provide details if YES
C. Other biohazard	YES/NO	Provide details if YES
D. Chemical or substances hazardous to health	YES/NO	Provide details if YES
E. Radioactive substances State name(s) and quantities of isotopes and checks made for residual activity	YES/NO	Provide details if YES
F. Other hazards	YES/NO	Provide details if YES
2. Please provide details of any hazard present as indicated above. Include details of names and quantities of agents as appropriate:-		
3. Your method of decontamination (please describe):-		
4. Are there likely to be any areas of residual contamination (please specify)		
I declare that the above information is true and complete to the best of my knowledge and belief.		
Authorised signature:-	Name (please print):-	
Title/Position:-		
For and behalf of:-	Date:-	

11. Customer Support.

For help and support in using this product, please contact Customer Services at the following address.

Bibby Scientific Limited.
Beacon Road,
Stone,
Staffordshire ST15 0SA,
Great Britain.

Tel: +44(0)1785 812121
Fax: +44(0)1785 810405

- General enquiries :
info@bibby-scientific.com
- Order enquiries :
sales@bibby-scientific.com
- Technical support :
electrothermalhelp@bibby-scientific.com
- www.electrothermal.com

For the America's and Canada, contact:
Techne Incorporated, 3 Terri Lane,
Suite 10 Burlington, NJ 08016 USA.

Toll free:800-225-9243Tel: 609-589-2560
Fax: 609-589-2571
Email: labproducts@techneusa.com
Http www.techneusa.com

12. EC Declaration of Conformity.

CE marked products and associated accessories covered by this Instruction book conform to the essential requirements of the following directives:

EMC Directive.
Low Voltage Directive.

A full copy of the EC Declaration / Conformity document can be obtained from the manufacture at the email address : info@bibby-scientific.com



Bibby Scientific Limited.

Beacon Road,
Stone,
Staffordshire ST15 0SA,
Great Britain.

Tel: +44(0)1785 812121
Fax: +44(0)1785 810405

- General enquiries :
info@bibby-scientific.com
- Order enquiries :
sales@bibby-scientific.com
- Technical support :
electrothermalhelp@bibby-scientific.com
- www.electrothermal.com

For the America's and Canada, contact:

Techne Incorporated, 3 Terri Lane,
Suite 10 Burlington, NJ 08016 USA.

Toll free:800-225-9243Tel: 609-589-2560
Fax: 609-589-2571
Email: labproducts@techneusa.com
Http www.techneusa.com

Part of the Bibby Scientific Group



© 2013 Bibby Scientific Limited. All rights reserved.