

AIR SCREAMER

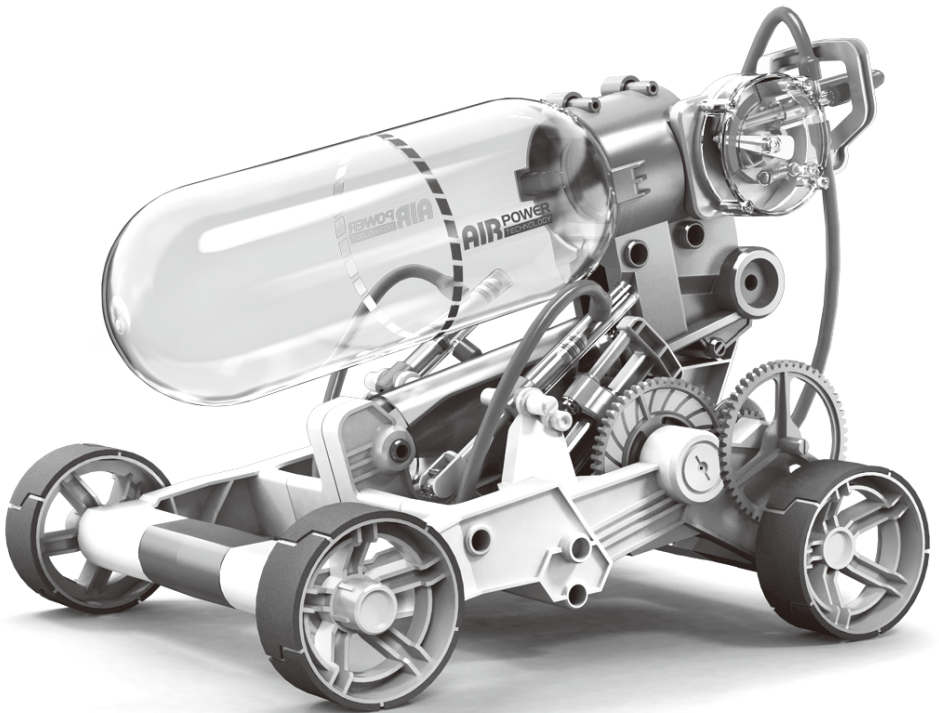

ASSEMBLY & INSTRUCTION MANUAL

CONTENTS

Introduction	P.1
Tools You May Need	P.1
Mechanical Parts List	P.1
Plastic Parts	P.3
TIP: Cut off Burrs	P.4
Cut and Fit Air Tubes	P.4
Tube Module Assembly	P.5
Testing Air Leaks	P.13
Vehicle Body Module Assembly	P.17
How To Play	P.42
Trouble Shooting	P.43

Introduction

This amazing vehicle is fast and furious -and powered by AIR!

Watch and learn as compressed air explodes out of the tank to run a pneumatic motor powering gears and moving your vehicle. Compressed air vehicles have been in the works for years with functional locomotives in the 1870's and cars in early 20th century. This is the technology behind the fantastic vehicle that is the Air Screamer. Pump up the volume of air. Fill the tank one crank at a time.

The crank is built into the Air Screamer's body. Safety valves are in place that bleed off over pumped air and eliminate the possibility of disaster. If you crank too much, the safety valve lets out air until the tank reaches optimum pressure.

Assembly and operation is a breeze. A pump-up bar with a pressure meter is built into the car for easy operation. This meter measures the volume of compressed air. The silicon tube (red in color) creates an air tight fit. When the air chamber is full, you can release the compressed air; the air then expands and drives the vehicle a distance up to 165 Feet (50 meters) in 35 seconds. The Air Screamer is amazingly fun and requires no batteries or specific weather conditions to limit its usage. It's compact, fill with air, and get ready to watch it zoom!

For builders ages 10 and up.

Tools You May Need

Diagonal Cutter

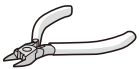

Screwdriver



Hammer

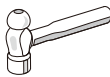

Scissors



Safety Glasses



Permanent Marker



Ruler



Tissue Paper



Mechanical Parts List



- Important: If any parts are missing or damaged, DO NOT RETURN TO THE RETAILER. E-mail us at support@elenco.com or call (800) 533-2441
- Product contains functional edges and sharp points.

P1 Tapping Screw

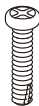
	QTY
	20

P2 Tapping Screw

	QTY
	6

P3 Round Shaft

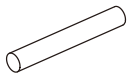
	QTY
	1

P4 Round Shaft

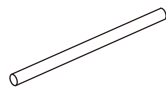
	QTY
	1

P5 Round Shaft	
	QTY
	1

P6 Hex Shaft (Short)	
	QTY
	1

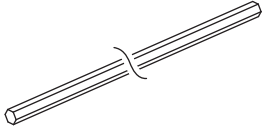
P7 Hex Shaft (Long)	
	QTY
	1

P8 Spring	
	QTY
	1

P9 O-ring (Black)	
	QTY
 (Spare part : 1 pc)	2

P10 Red Cap (Small)	
	QTY
 (Spare part : 1 pc)	7



P11 Red Cap (Medium)	
	QTY
	2

P12 Red Cap (Big)	
	QTY
	1

P13 Spacer	
	QTY
	1

P14 Bottle Top	
	QTY
	1

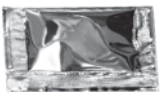
P15 Silicon Tube	
	QTY
	1

P16 Oil Bag	
	QTY
	1
 Do not touch the oil while fitting the silicon tube.	

P17 Valve (Clear Blue)	
	QTY
 (Spare part : 1 pc)	2

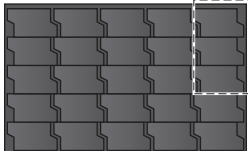
P18 Sponge	
	QTY
 Spare parts	1

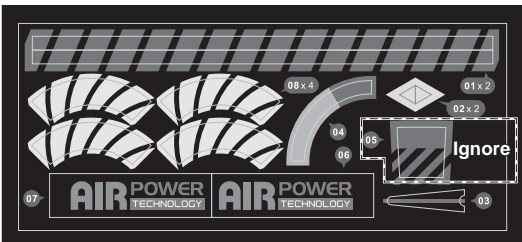
P19 Sticker	
	QTY
 07 AIR POWER TECHNOLOGY AIR POWER TECHNOLOGY 08 x 4 01 x 2 02 x 2 04 05 Ignore 06 03	1

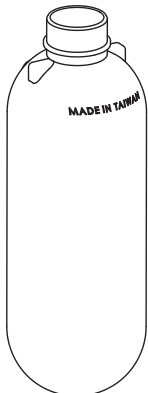
P20 PET Bottle	
	QTY
 MADE IN TAIWAN	1

Plastic Parts

! Cut the plastic parts when they are required.
Do not cut them in advance.

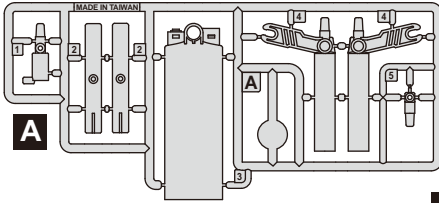

A

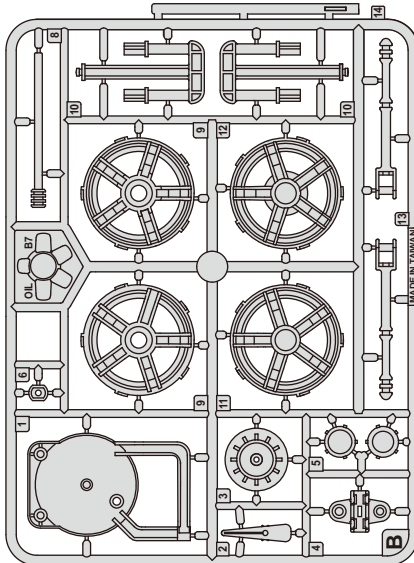

B

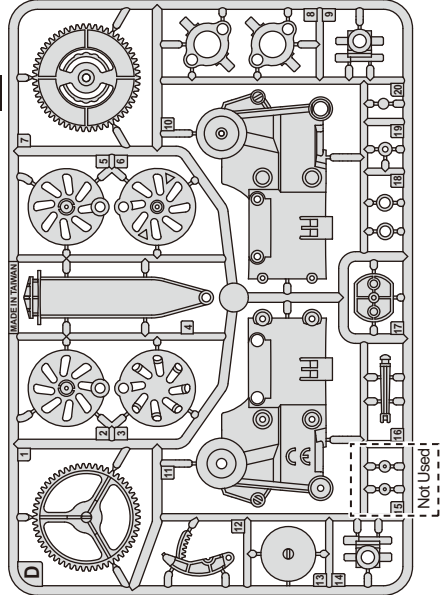

D

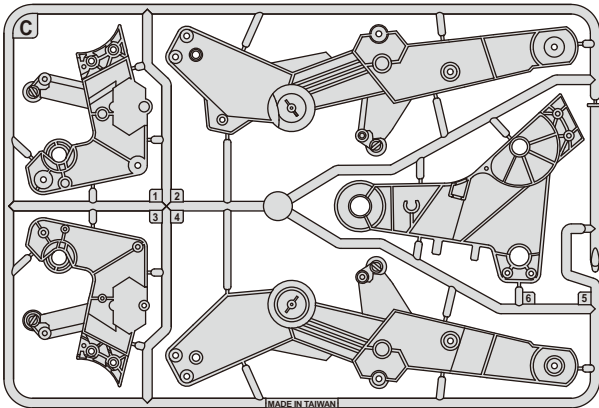

C

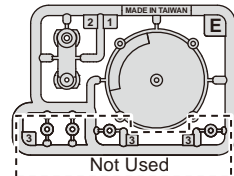

E

Tip : Cut Off The Burrs Before Assembly

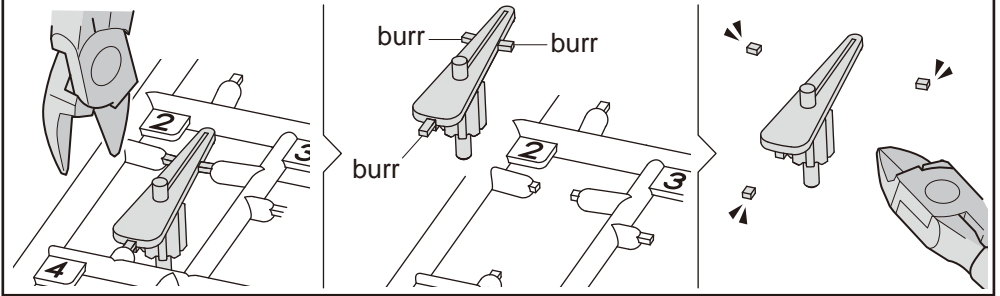

How To Fit Air Tube

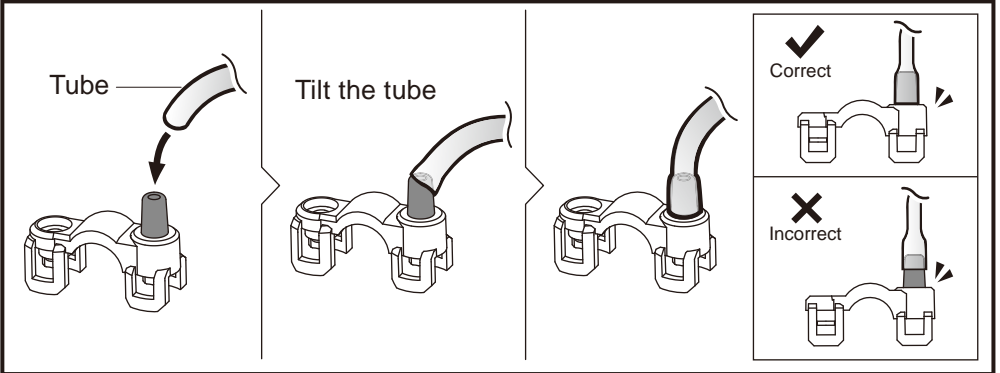

How To Cut Air Tube

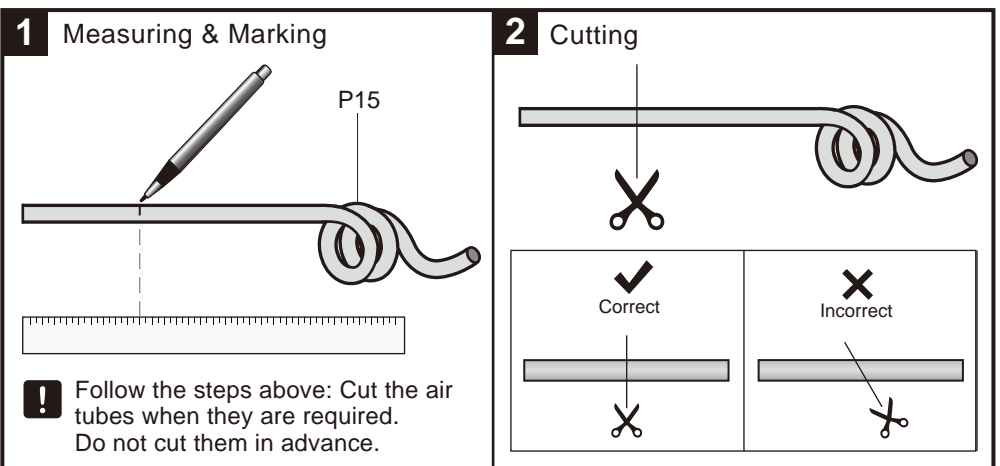

Tube Module A Assembly

1

! Prepare air tube before assembly.

Scale
1:1

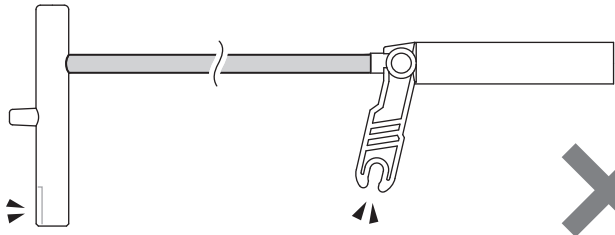
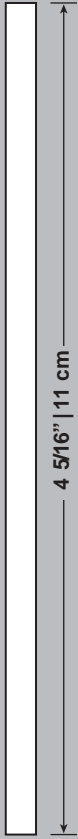
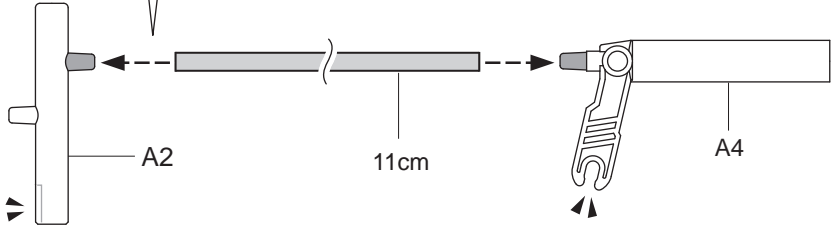
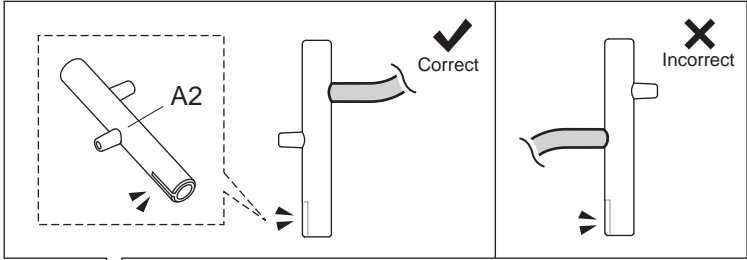

x2

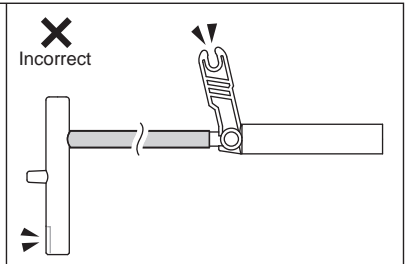
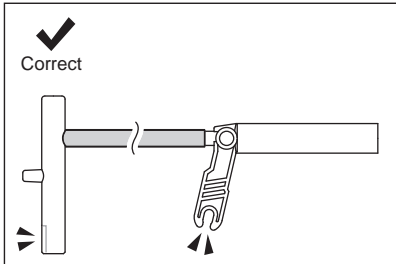

x2

2

! Prepare air tube before assembly.

Scale
1:1

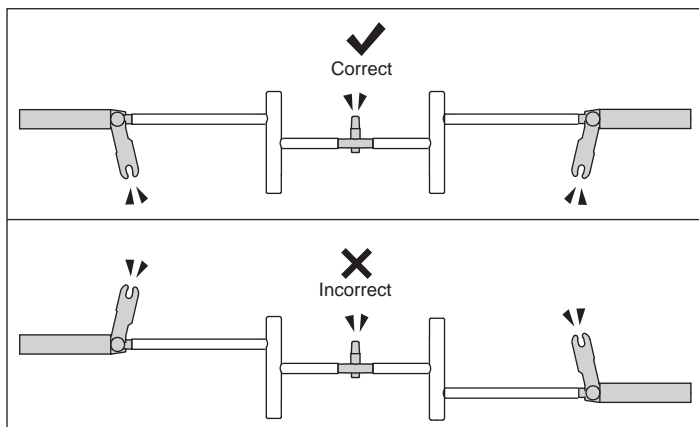
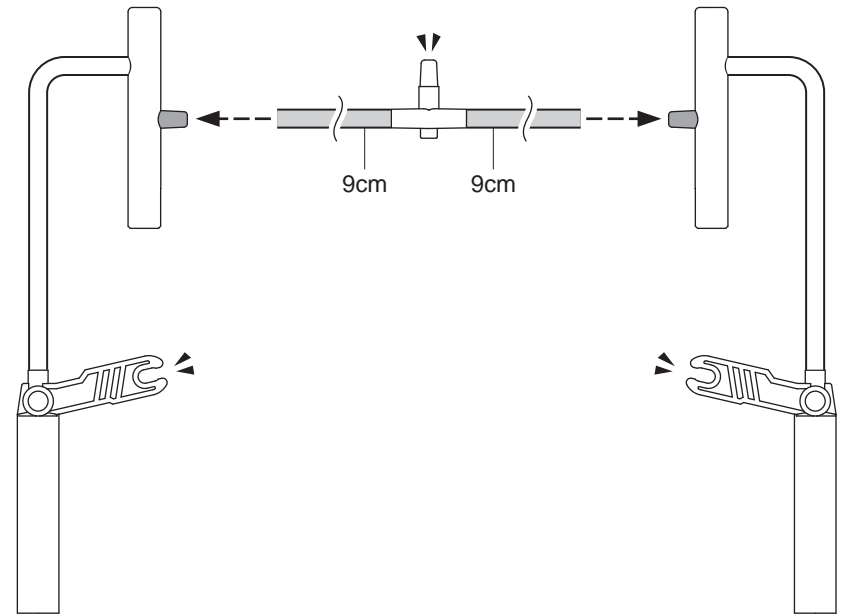
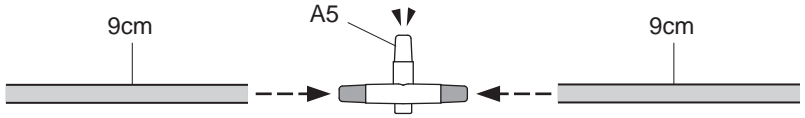

x2

Tube Module B Assembly

Scale
1:1

1

! Prepare air tube before assembly.

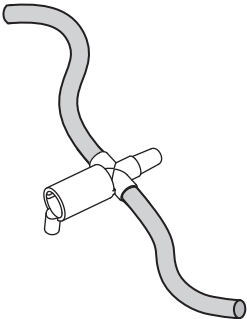
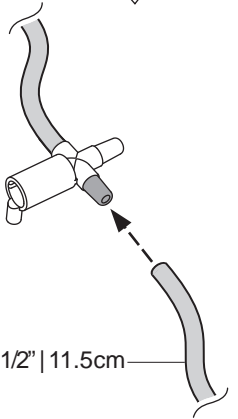
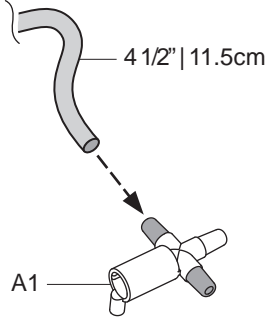

x2

Scale
1:1

2

! Prepare air tube before assembly.

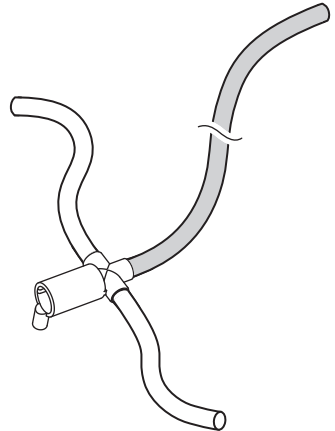
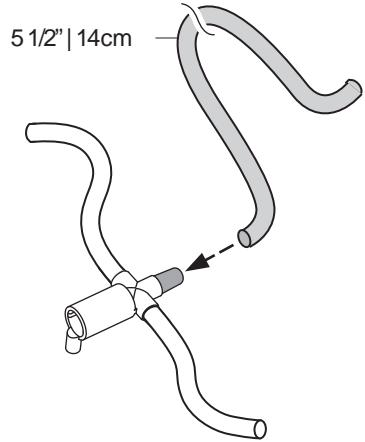

x1

3

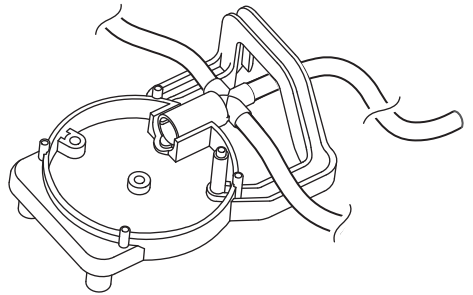
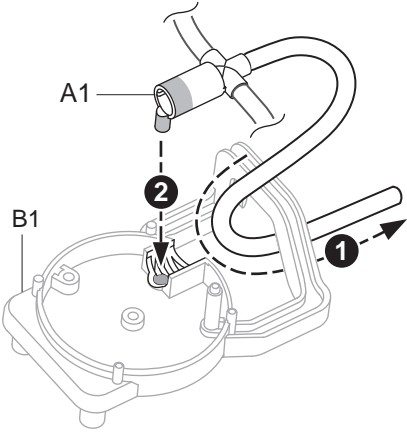

4

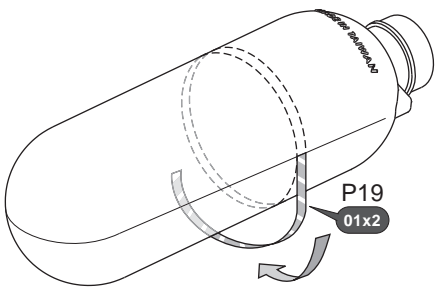
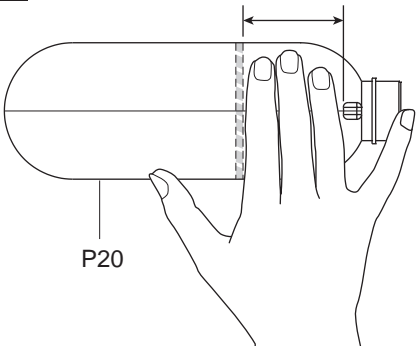

5

! Screw on P14 onto PET bottle tightly to avoid air leakage.

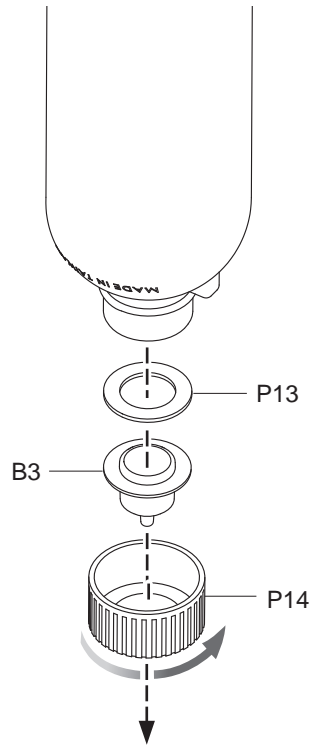

6

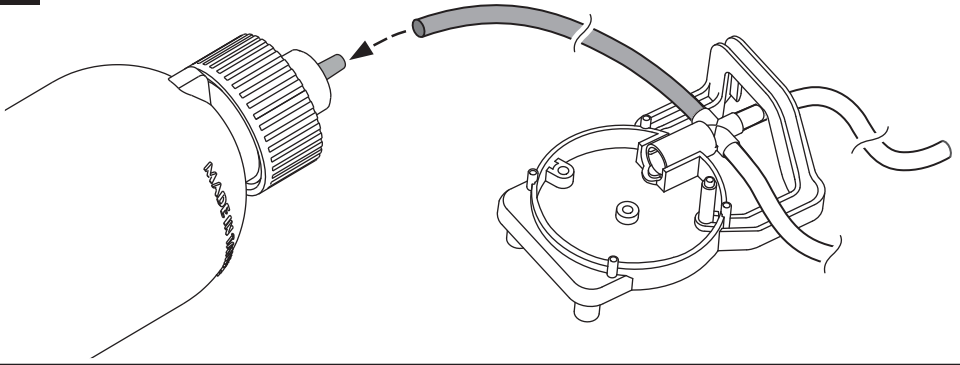

How To Oil The Parts

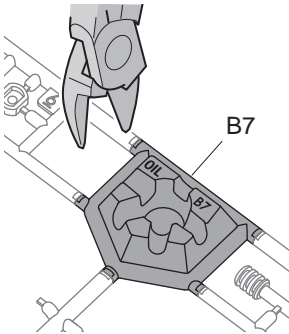

Tissue Paper

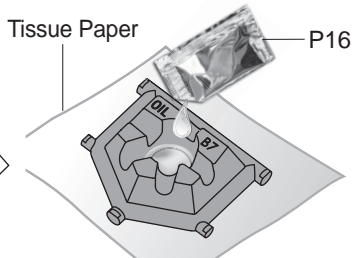

Do not spill any oil from the B7 oil bowl. Keep oil contained.

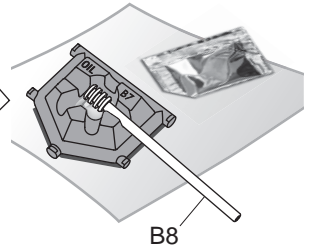

= Apply Oil

Note : Oil the parts when  appears



Do not oil outside the noted shaded areas as shown below.

Example:

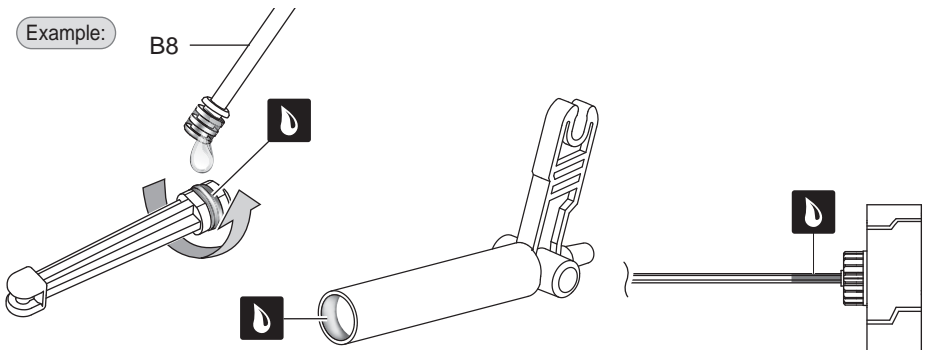

Video Tips

View a video on this project at <https://www.elenco.com/teachtech/>

To better understand the assembly and operations of each project, view the Video Tips.

7  Make sure P10 is placed in the proper direction to avoid air leakage.

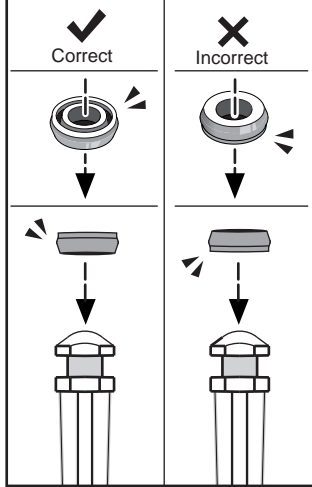

P10
Red Cap
(Small)

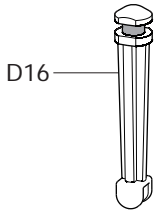

D16

Correct

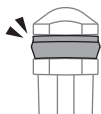

Incorrect

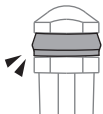

8

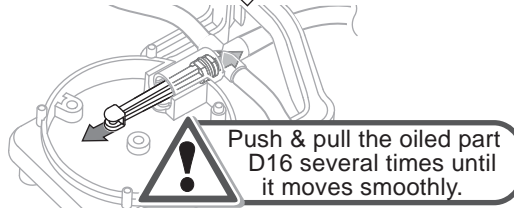
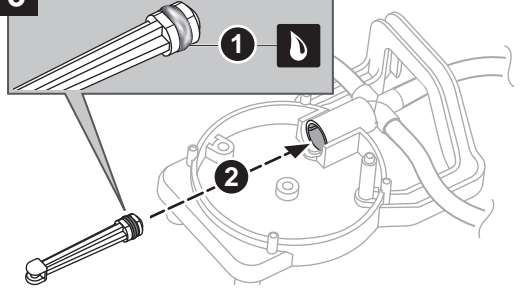

Push & pull the oiled part D16 several times until it moves smoothly.

9

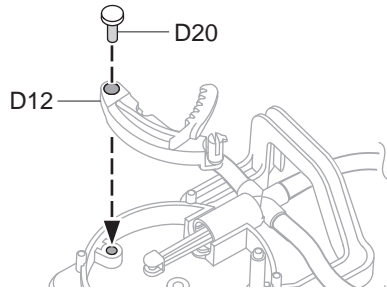

10

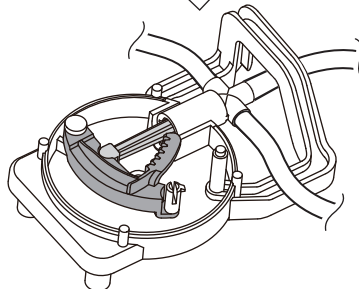
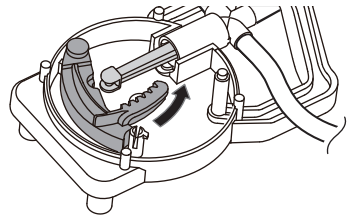

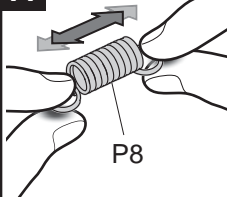
11

P8

Note:

Lightly pull on both ends of the spring to make sure it has good strength & extension before assembly.

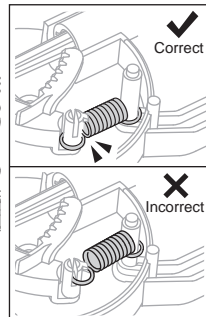
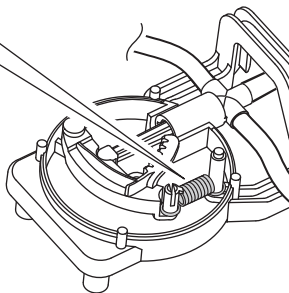
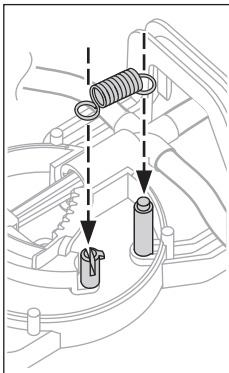
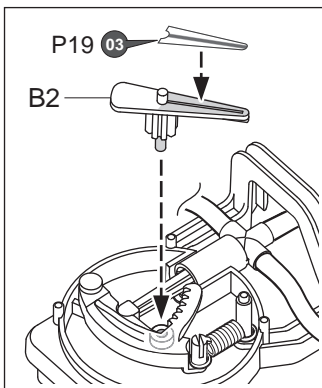
**12**

P19 03
B2

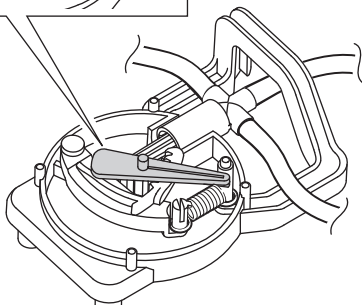
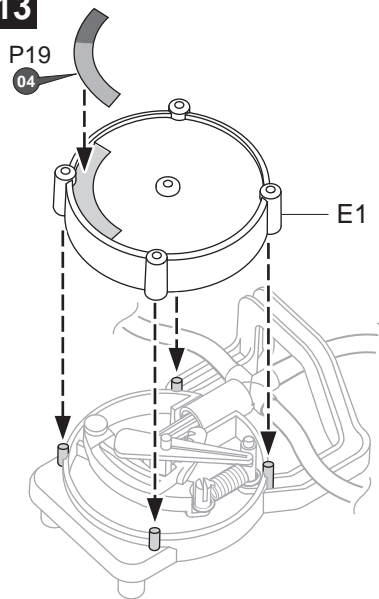
**13**

P19 04
E1

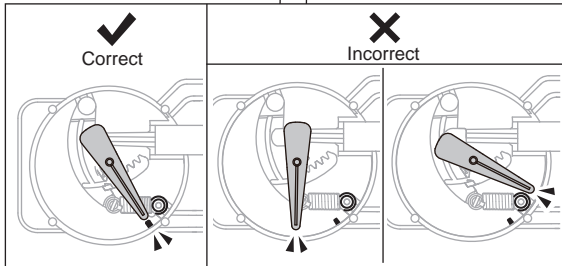
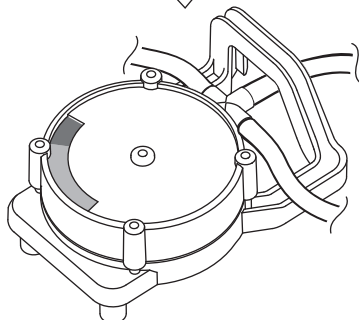

✓
Correct

✗
Incorrect

Valve Assembly

▶ Video Tips

Pay close attention to the following steps correctly to avoid air leakage.

View a video on this project at <https://www.elenco.com/teachtech/>

1

C5

E2

P9 O-ring (Black)

Use C5 to assist you in setting P9 onto E2.

Incorrect

2

P9 O-ring (Black)

A3

Correct

Incorrect

3

P17

P17

Correct

Incorrect

Ensure the direction of two P17 to avoid air leakage.

4

E2

A3

1 Straight A3 on the table, and put E2 on A3 flatly.

2 Press down E2 to A3 entirely.

Correct

Incorrect

5

B14

P4

Place P4 on the table, cap B14 to P4 as shown.

6

B14

1 Push P17 to the bottom (as per Fig 1) and make P9 flat against base.

2 Push P17 to the top (as per Fig 2) and make P9 to seat flatly.

Correct

Incorrect

If P9 (O-Ring) was seated improperly as shown in above incorrect (X) fig, re-do step 6 again.



Testing Air Leaks – The Valve

1

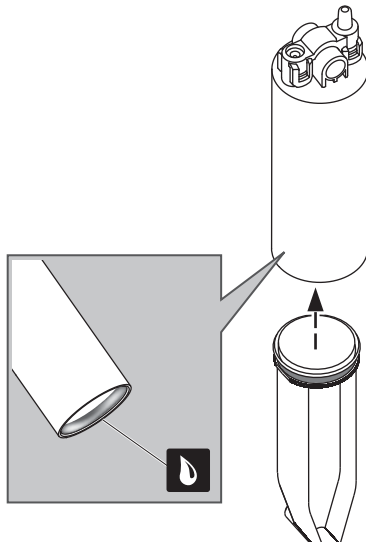
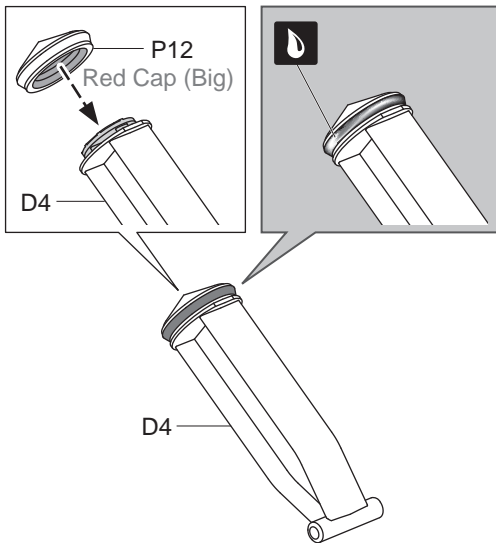

2

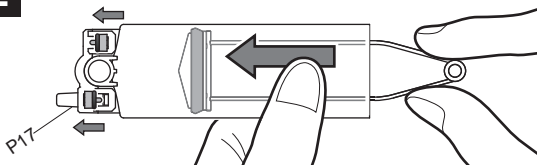

Make sure that both P17 move in the direction indicated by the arrows when D4 is pushed in.

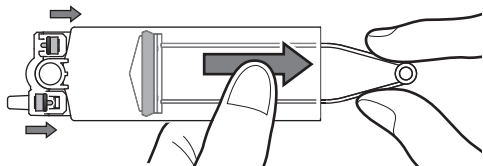

Make sure that both P17 move in the direction indicated by the arrows when D4 is pulled back.

2 Push in the D4.

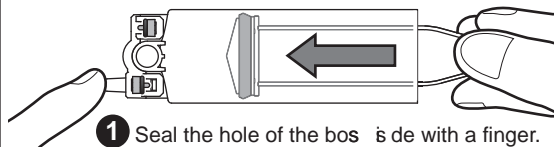

Confirm that D4 cannot be pushed in easily.

1 Seal the inlet hole with a finger.

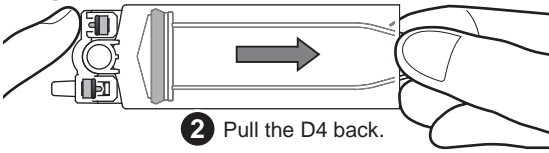

2 Pull the D4 back.

Make sure D4 is firm, when pulling D4 back.

Air leakage testing – Tube Module B

1

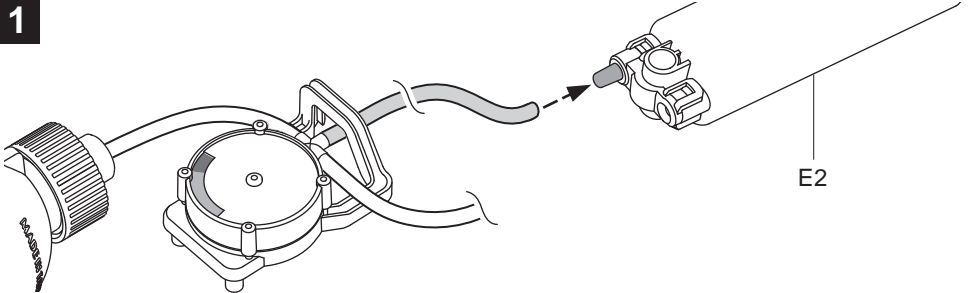

Correct

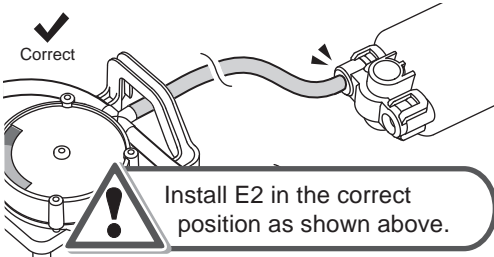

Install E2 in the correct position as shown above.

Incorrect

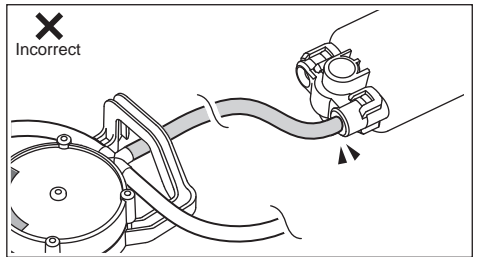

2

! Fold the tube and insert it into the hole as shown below.

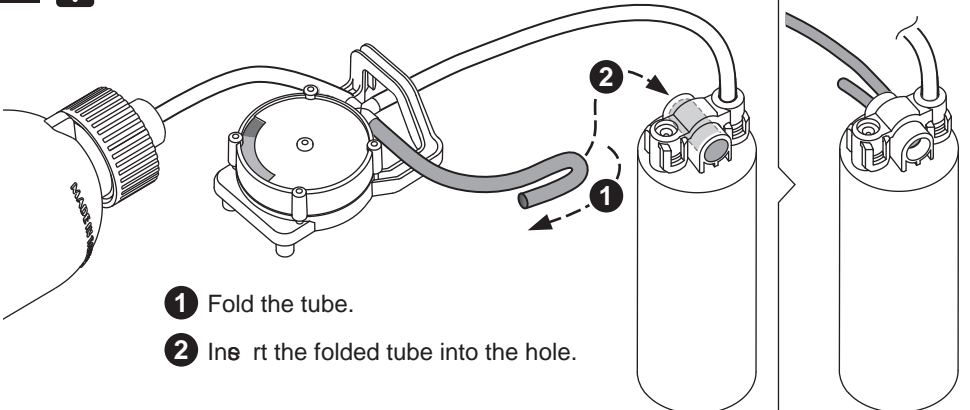

1 Fold the tube.

2 Insert the folded tube into the hole.

3

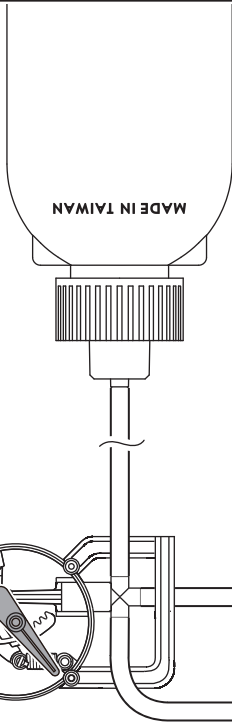

Hold A3 firmly!

Repeat a "Push & Pull" movement using D4 15-20 times to collect air into PET bottle.

Check that the pressure meter pointer swings to the left and holds its position.

Results shown below will reveal if tube module B is installed correctly or is leaking air .

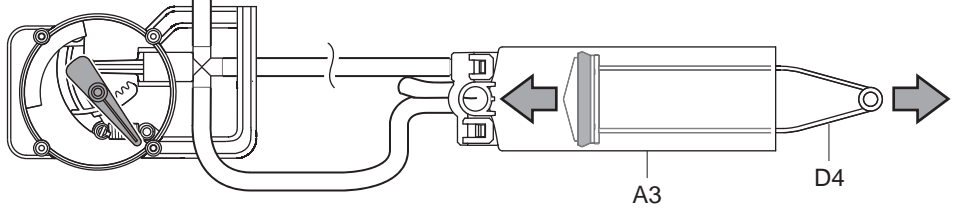

Air Leakage

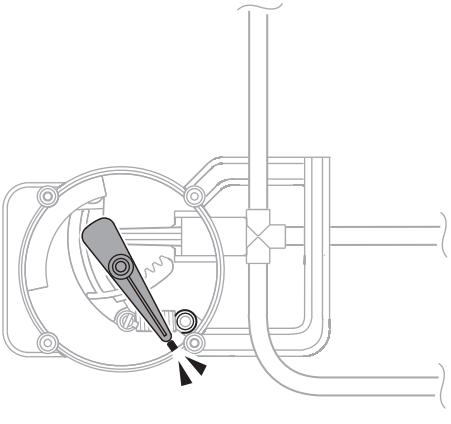

Pointer stays still

Working Functionally

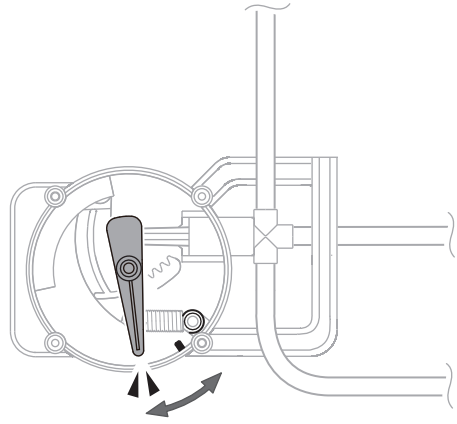

Pointer moves to the above position

Check the following locations if air leaks occurred, and re-install as below:

MADE IN TAIWAN

Location 1:

Location 1:

Back to page 8 , and re-install step 5 again.

Location 2:

Back to page10, and re-install steps 7-13 again.

Location 3:

Back to page12, and re-install steps 1-6 again.

Location 2:

Location 3:

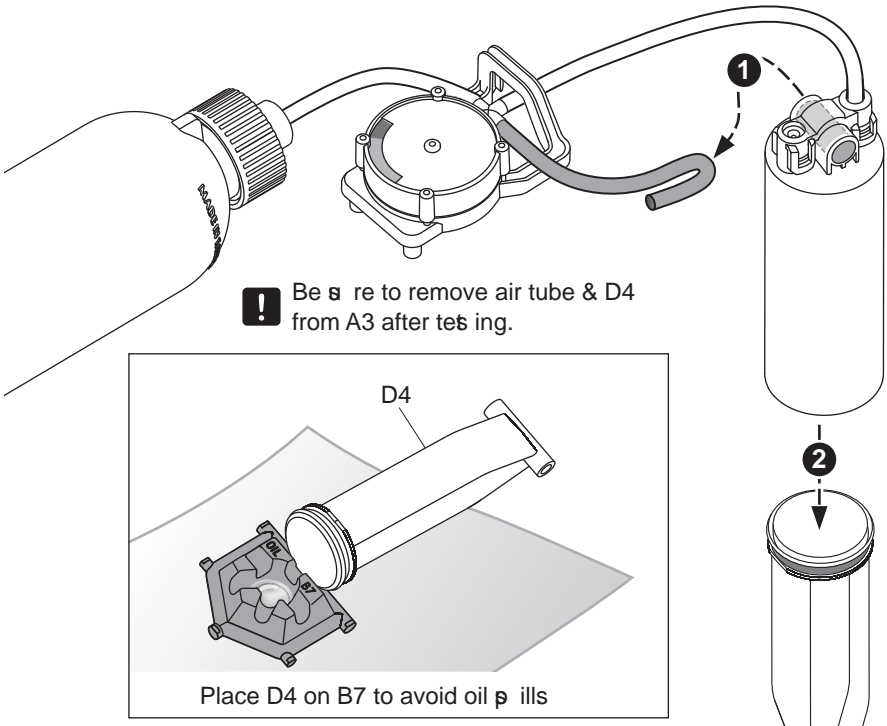

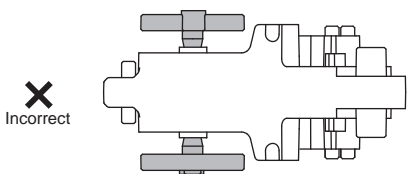
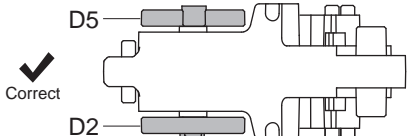
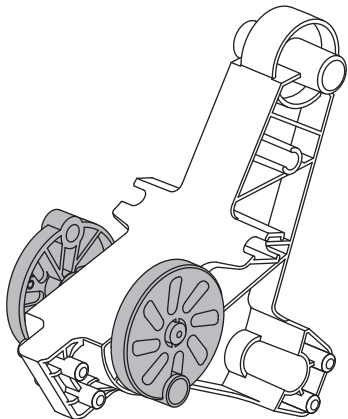

 Make sure parts D5 & D2 are properly connected as shown above.

3

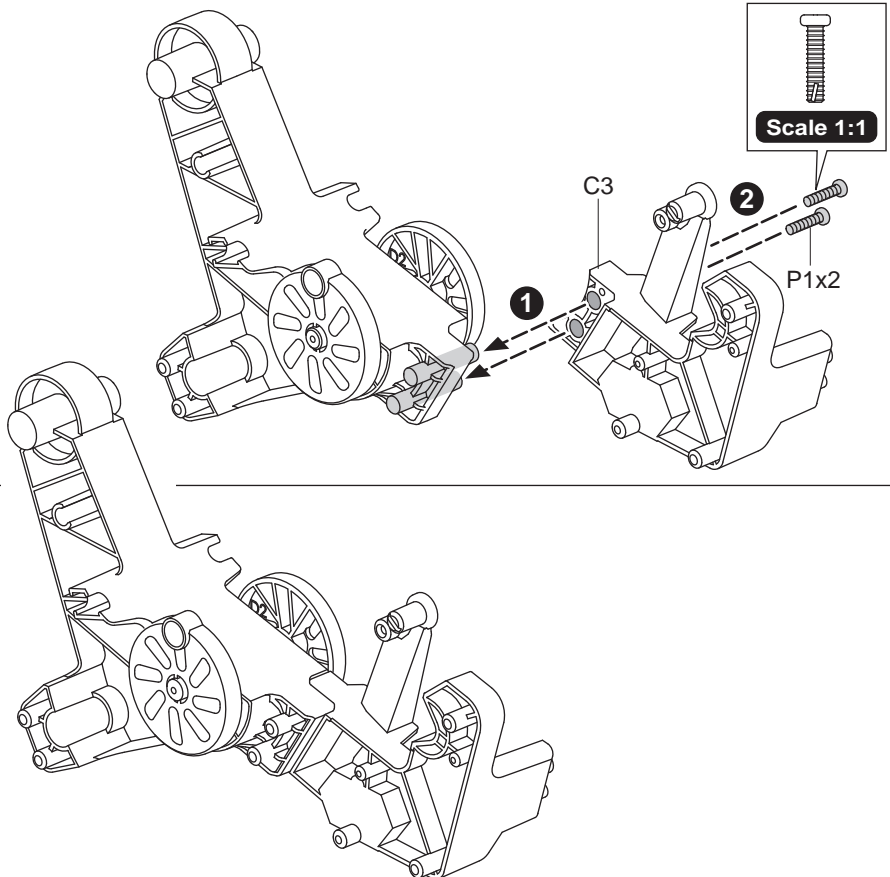

4

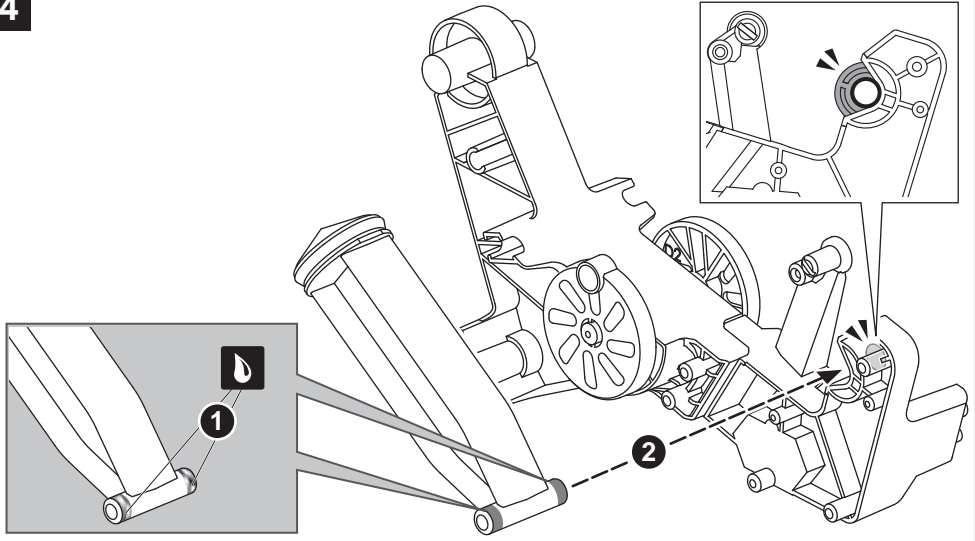

5

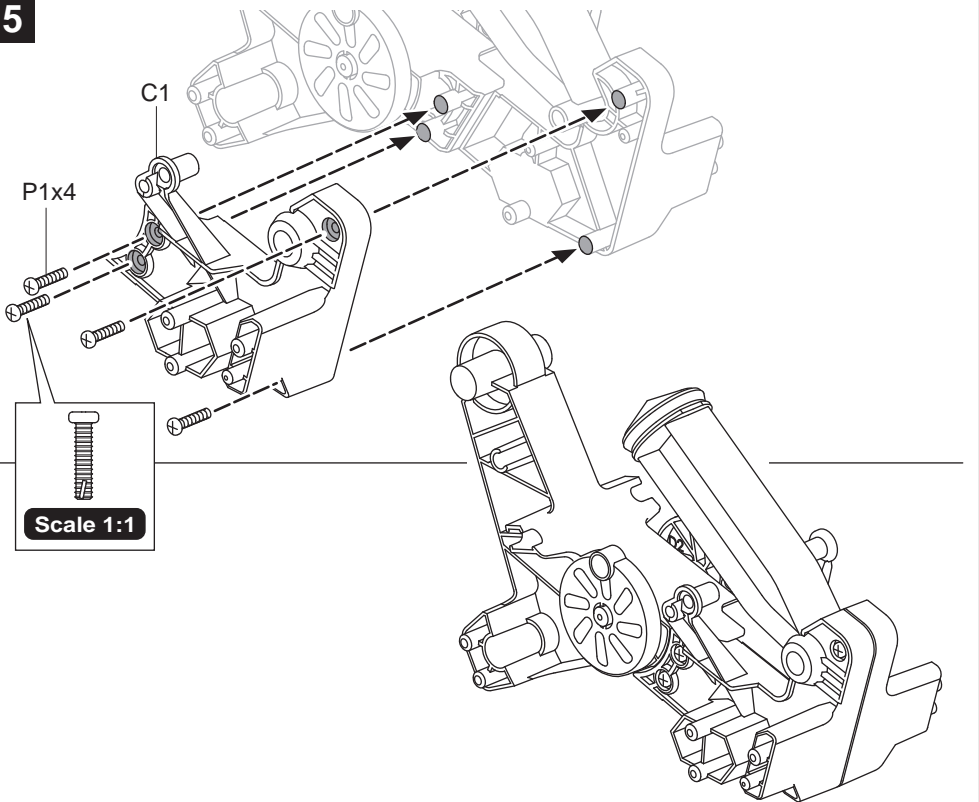

6



! Cut off burrs before assembly.

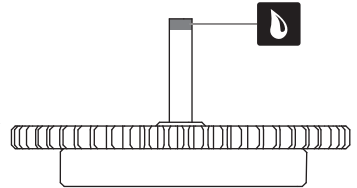
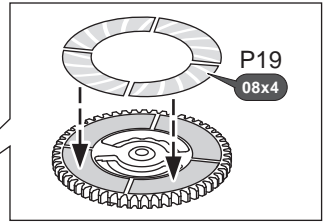
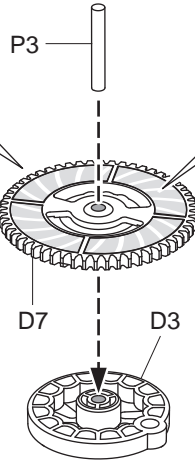
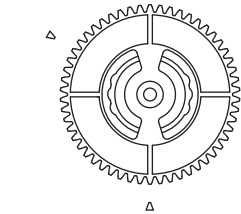
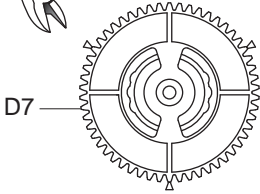

Scale 1:1

! Insert P3 to the bottom to match fig B own above. (Scale 1:1)

7

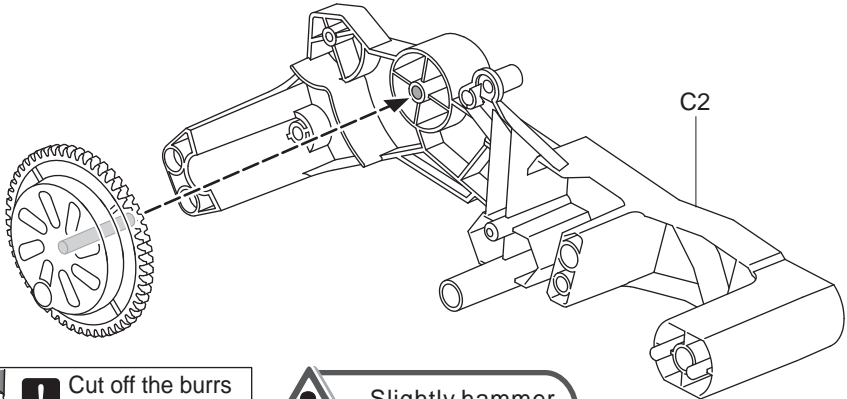

8



! Cut off the burrs before assembly.

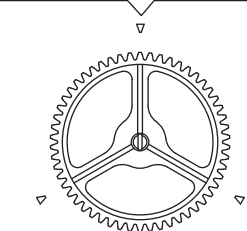
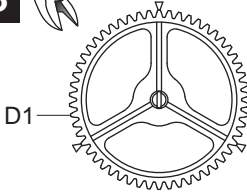

! Slightly hammer P5 into D1.

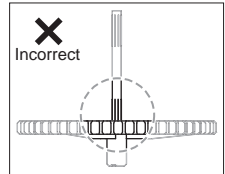
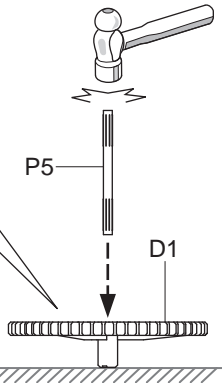

Scale 1:1

! Insert P5 to the bottom to match fig B own above. (Scale 1:1)

9

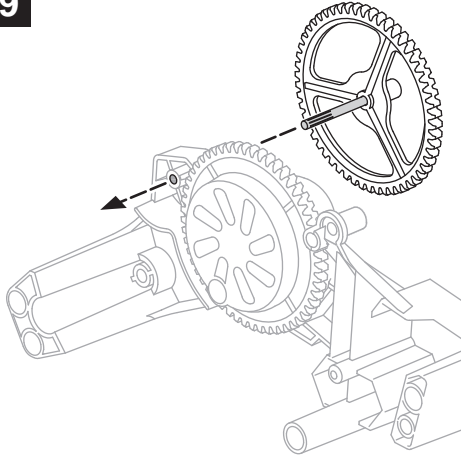

10

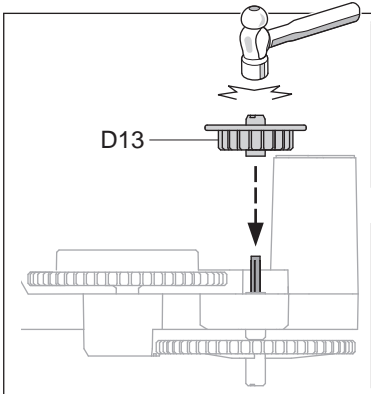
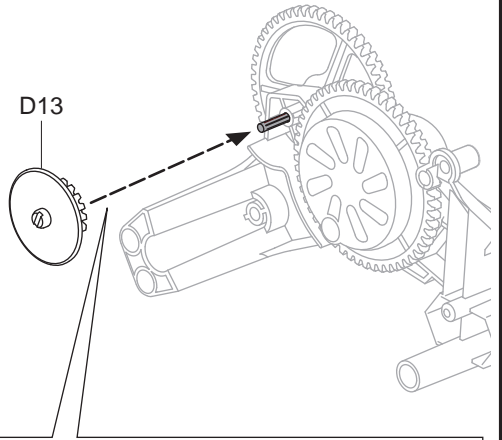

Gently tap D13 with hammer to the bottom as shown below.

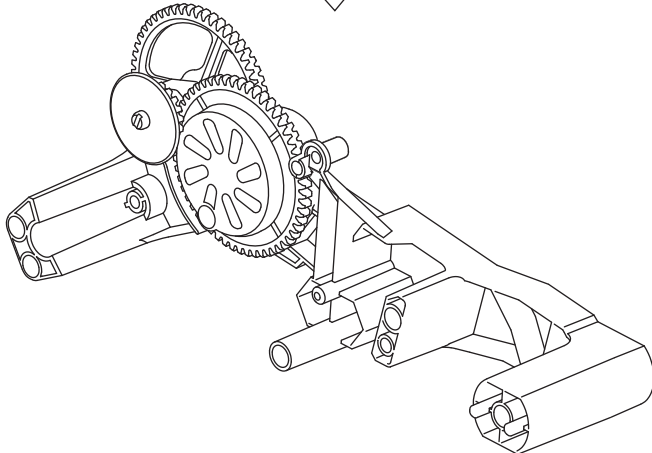
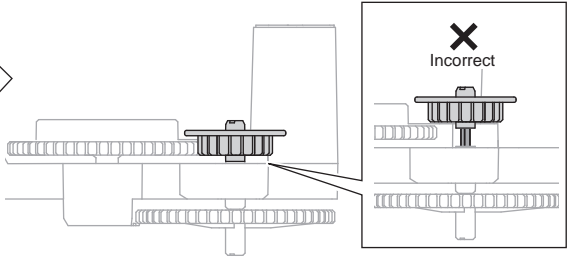



Make Sure P10 Set To B13 Step By Step As Shown Below.

11



Ensure that P10 is inserted in the proper direction to avoid air leaks.

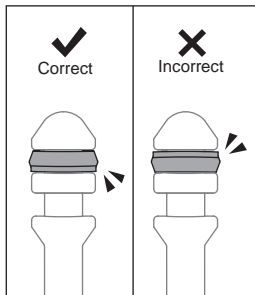
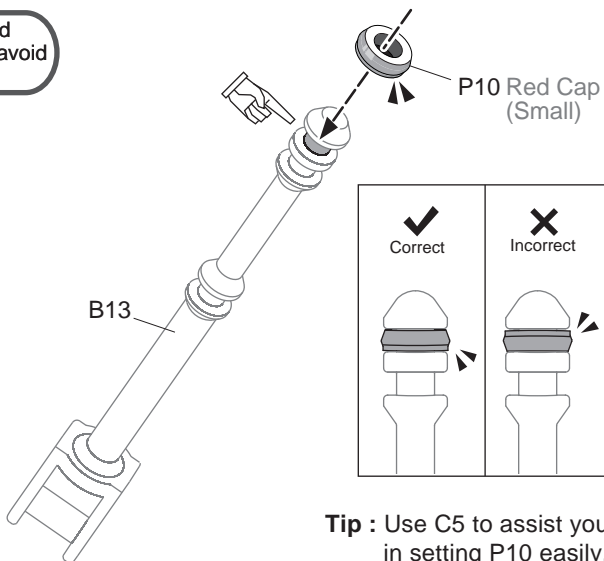
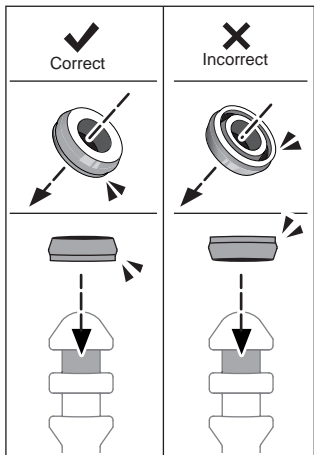

12



Ensure that P10 is inserted in the proper direction to avoid air leaks.

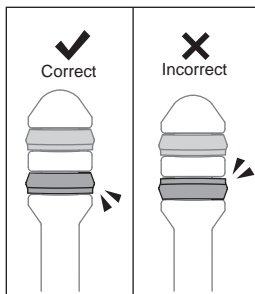
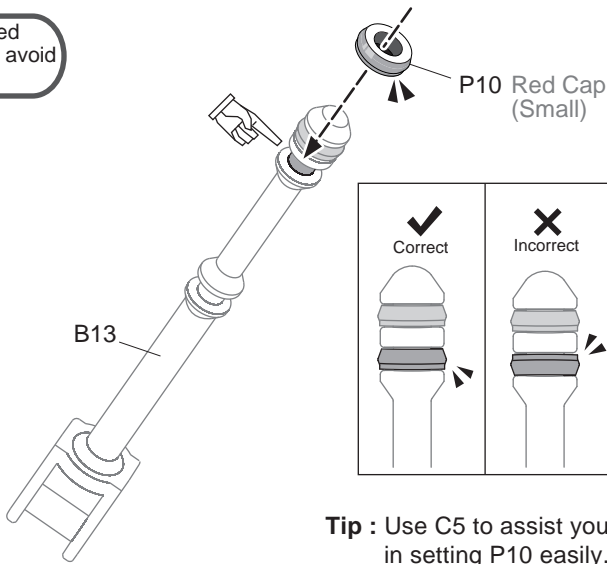
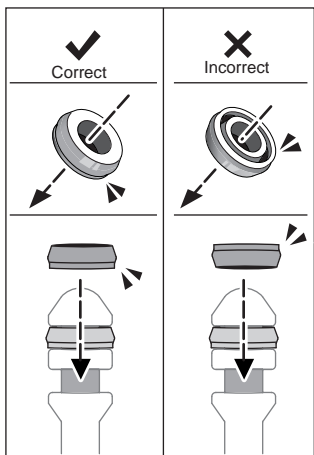

13

Ensure the direction of P10 to avoid air leakage.

Note: Direction of P10 on step 13 is different from step 11 & 12.



P10 Red Cap (Small)

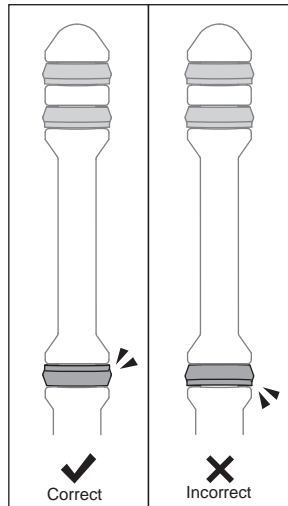
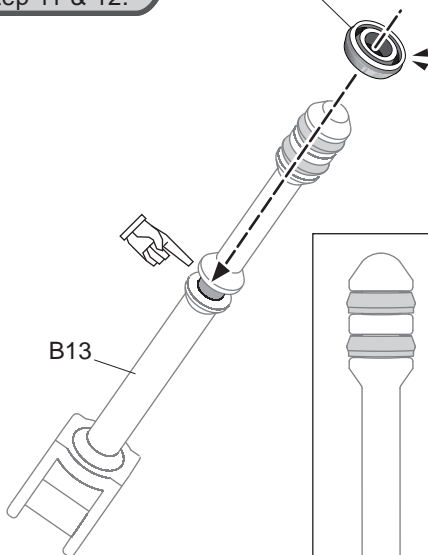
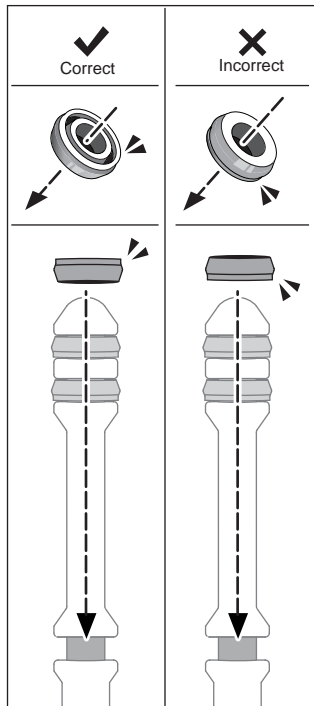

Tip : Use C5 to assist you in setting P10 easily.

Tip :

Use C5 to make it smooth if P10 was twisted during assembly.

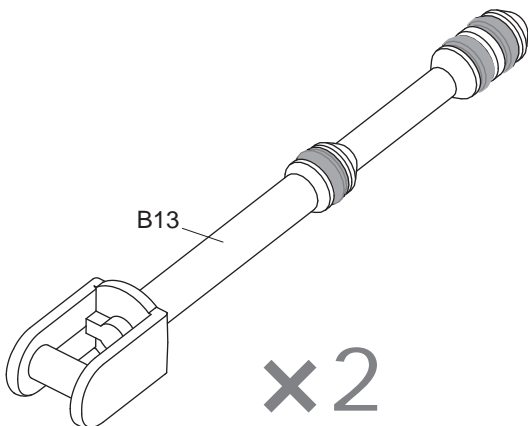
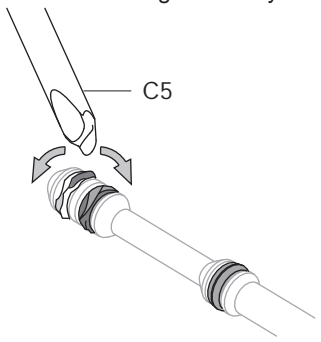

14

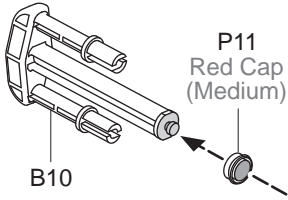
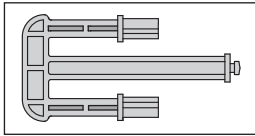

P11
Red Cap
(Medium)

B10

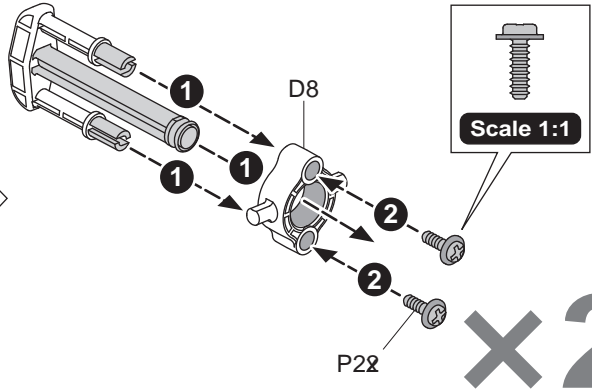

D8

Scale 1:1

P28

x2

15

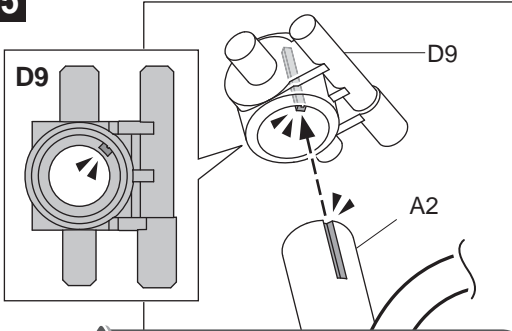

D9

D9

A2

Note:
Make sure to lock A2 / D9 firmly.

Do not mix up D9 & D14, make sure to use D9 for assembly.

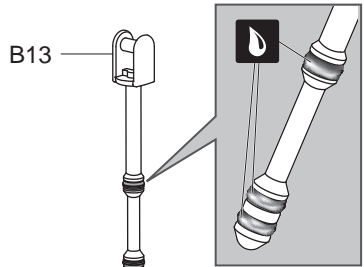

B13

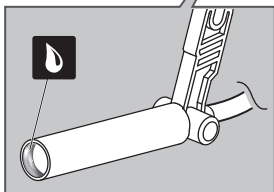
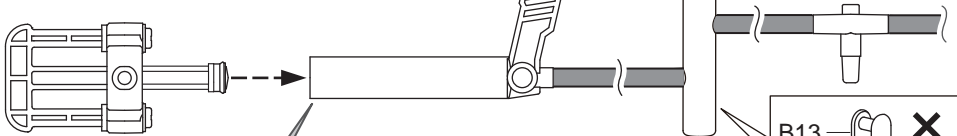

Take out B13 if P10 (Red Cap) was twisted during assembly. Un-twist P10 and re-insert B13 into A2.

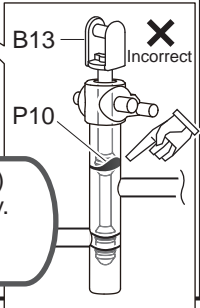



B13

P10

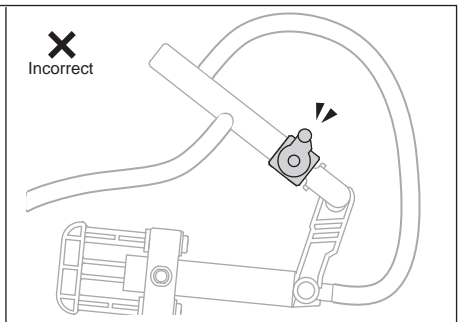
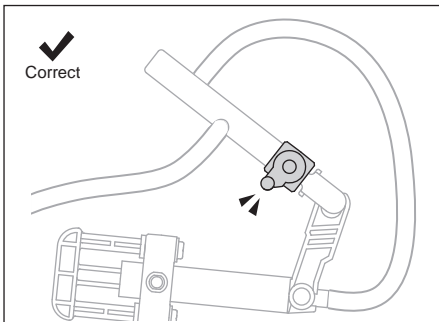
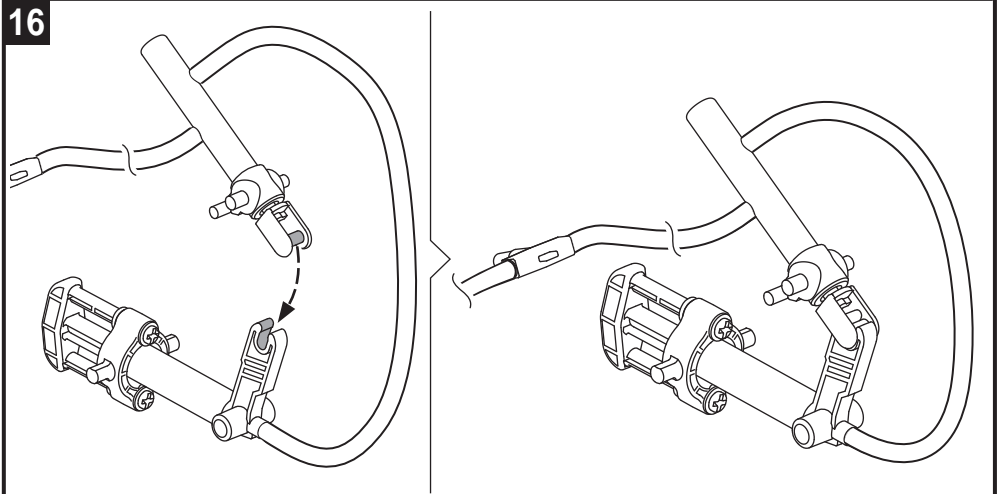
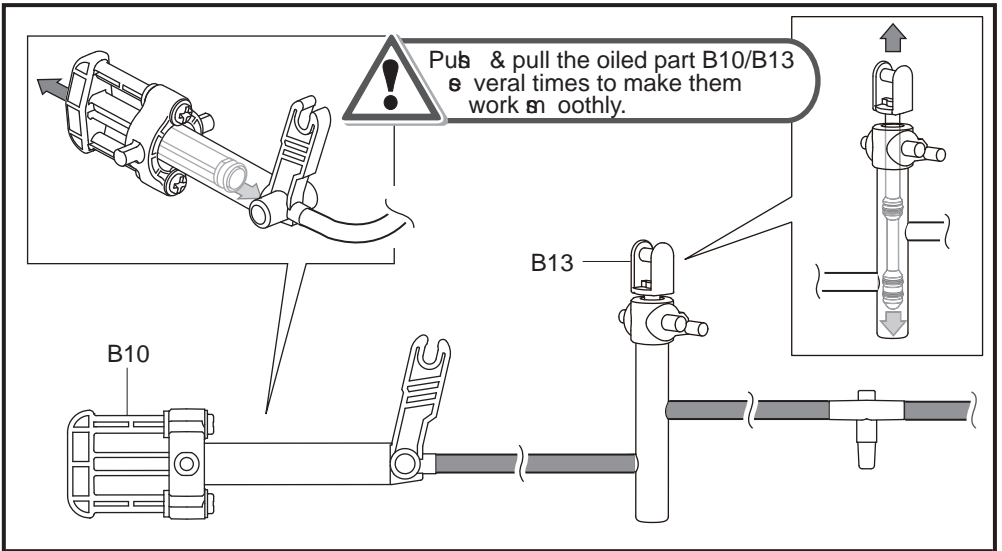
Incorrect

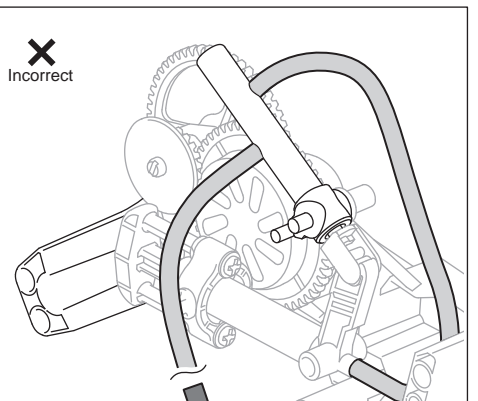
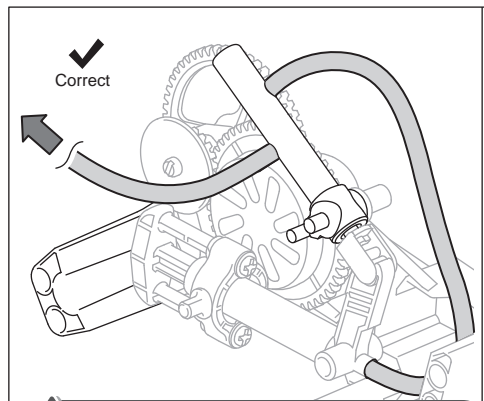
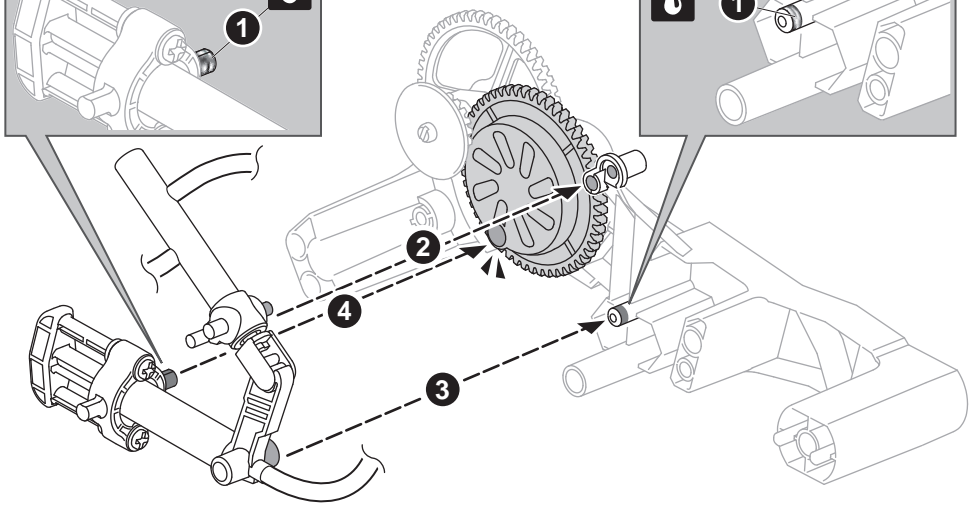
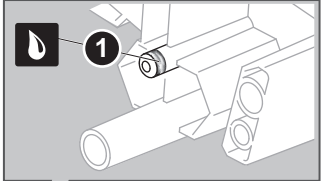
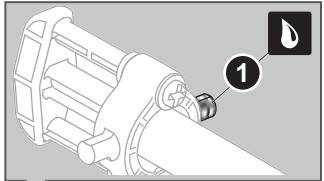
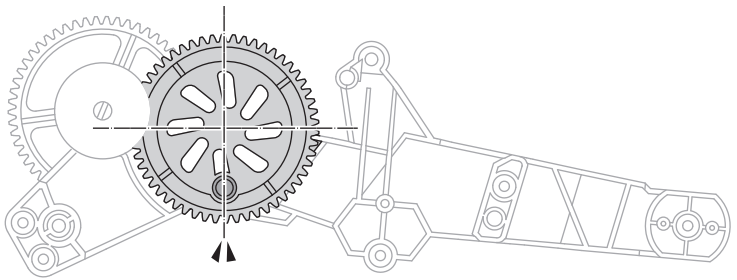



 Route the air tube to the position as shown above.

18

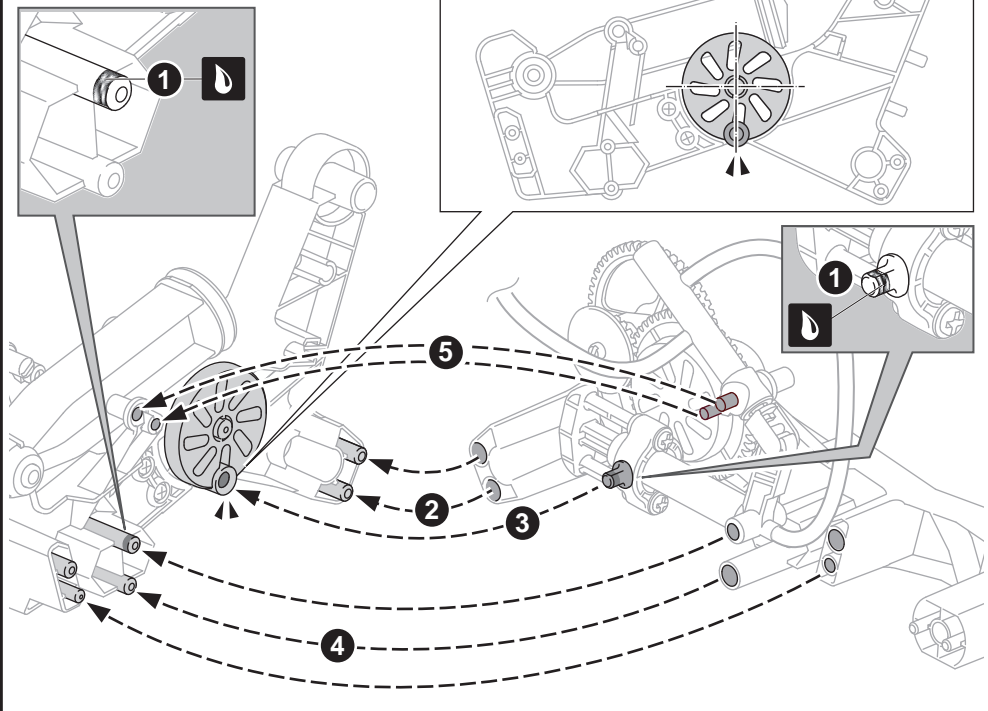

19

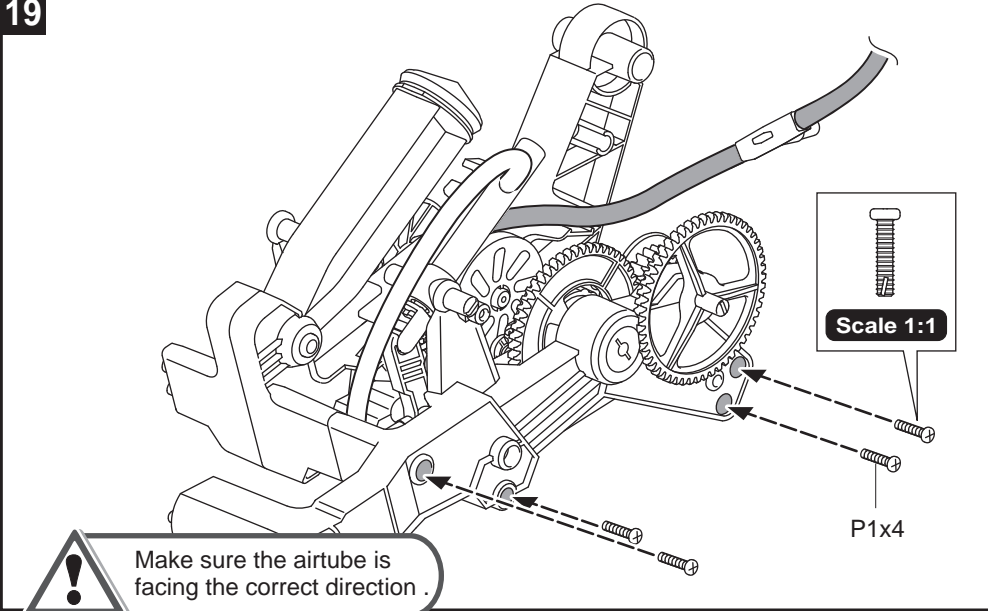

20

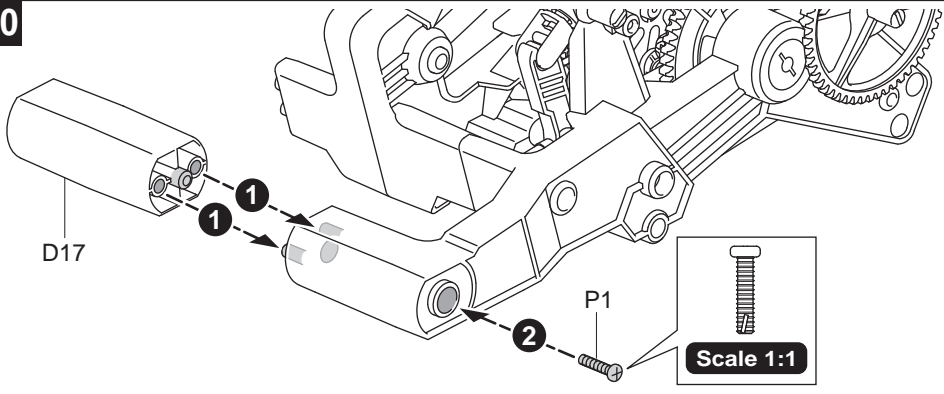

21

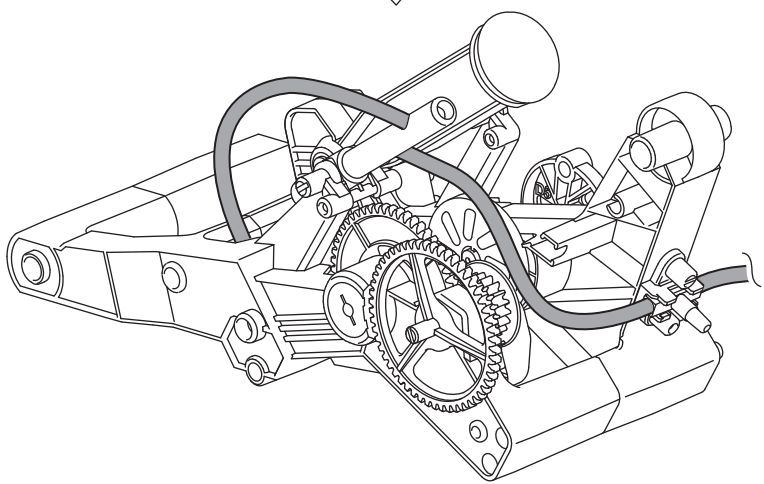
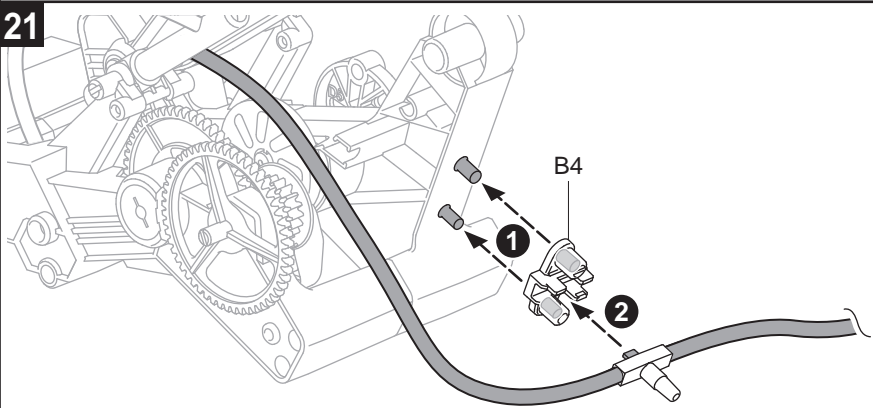

22

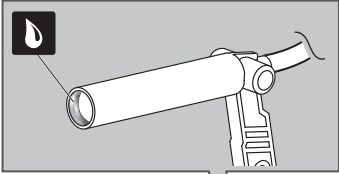

Take off B13 if P10 (Red Cap) was twisted during assembly. Untwist P10 and re-insert B13 into A2.

X
Incorrect

B13
P10

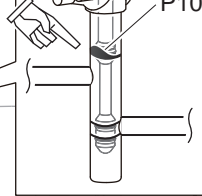
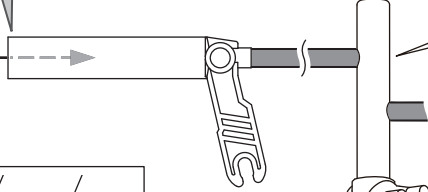
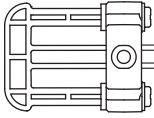

D14

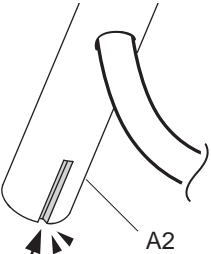
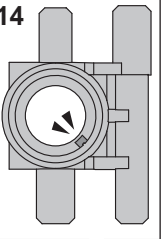

A2

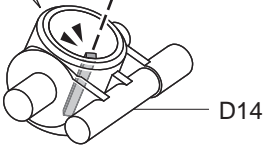

D14

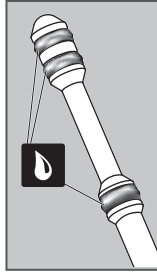

Note:
Make sure to lock A2 into D14 firmly.



Do not mix up D9 & D14, make sure to use D14 for assembly.

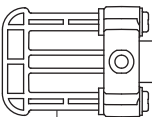

B10

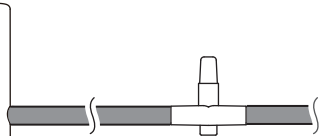

B13



Pump & pull oiled parts B10 and B13 several times to make sure they move smoothly.

23

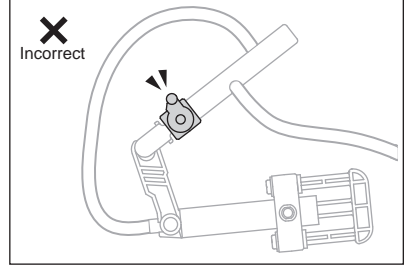
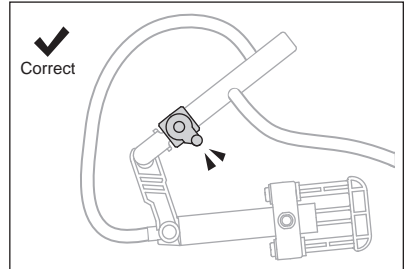
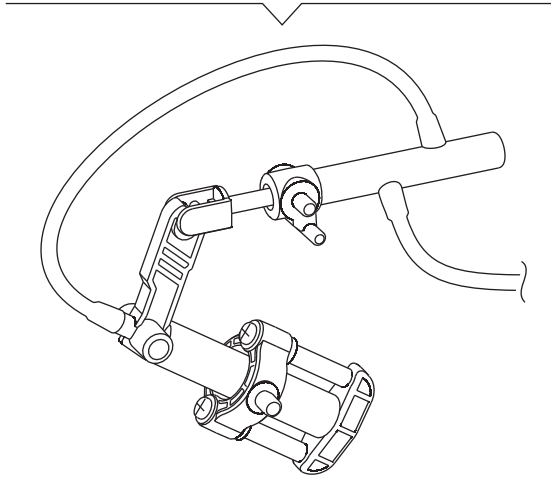
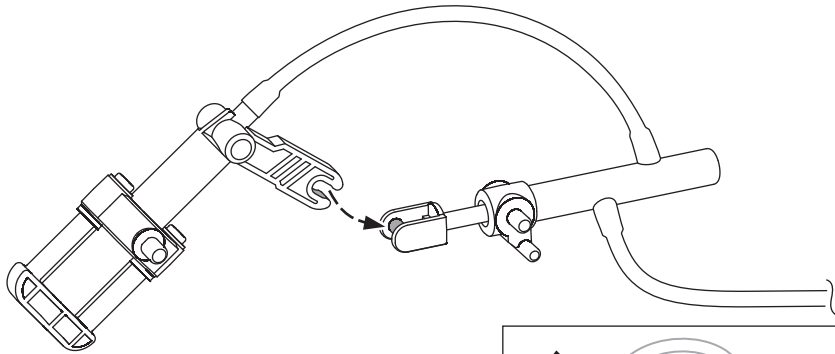

24

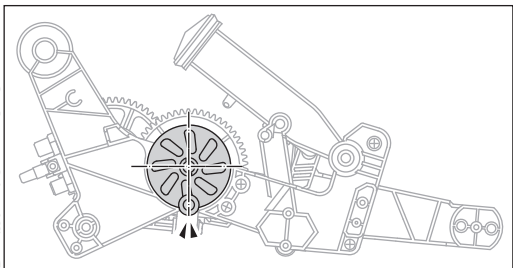
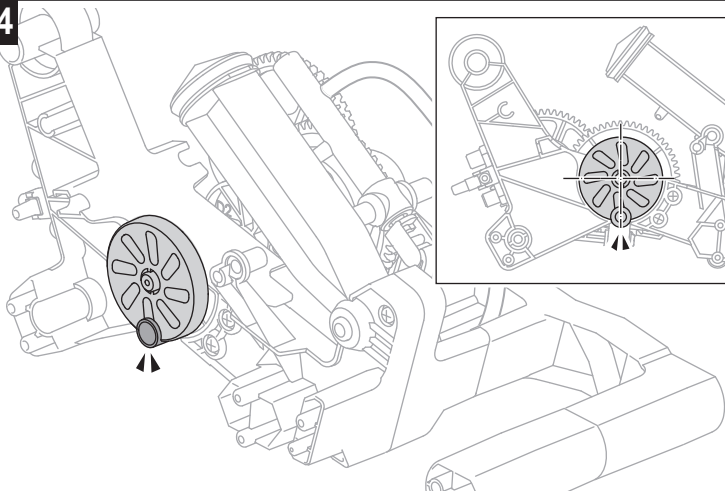

25

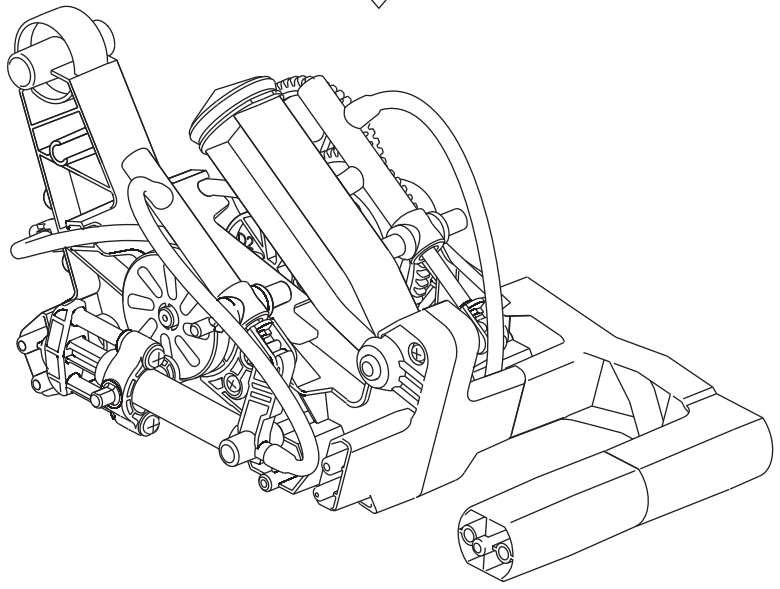
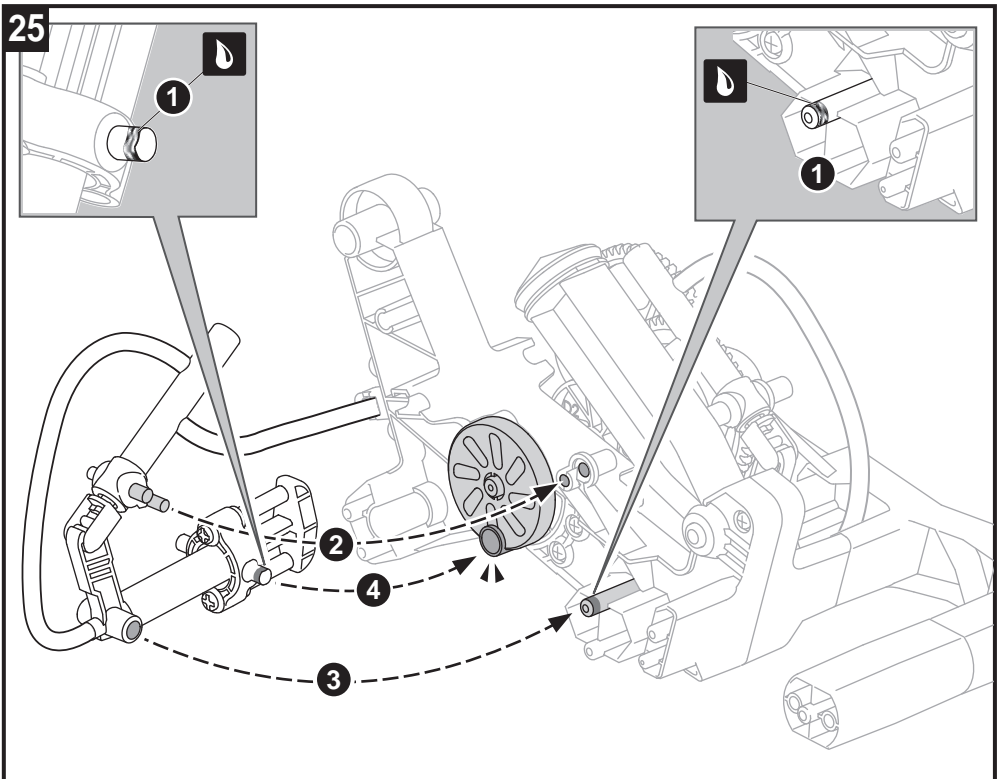

26

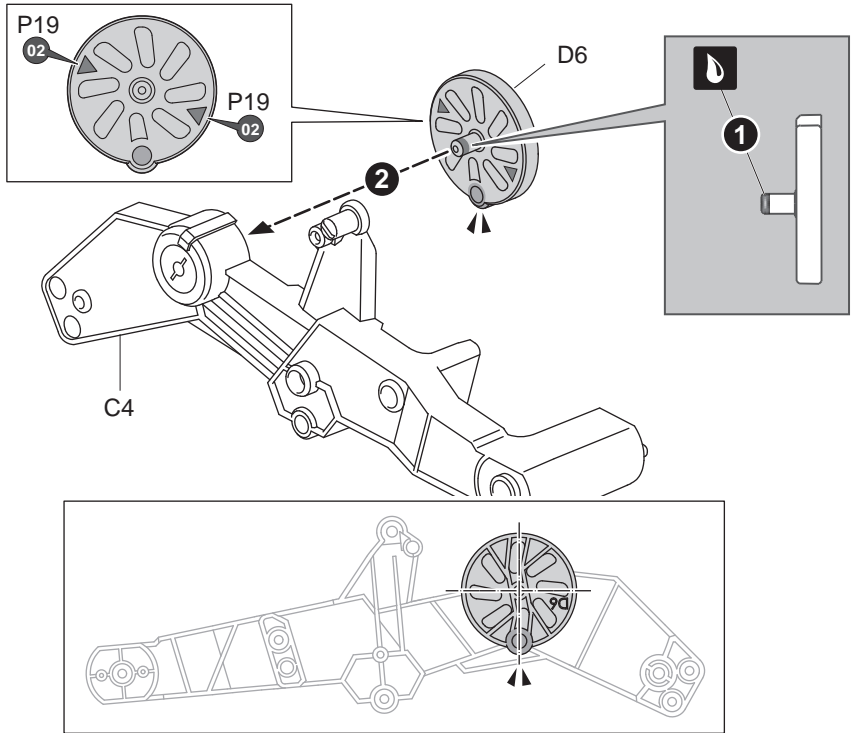

27

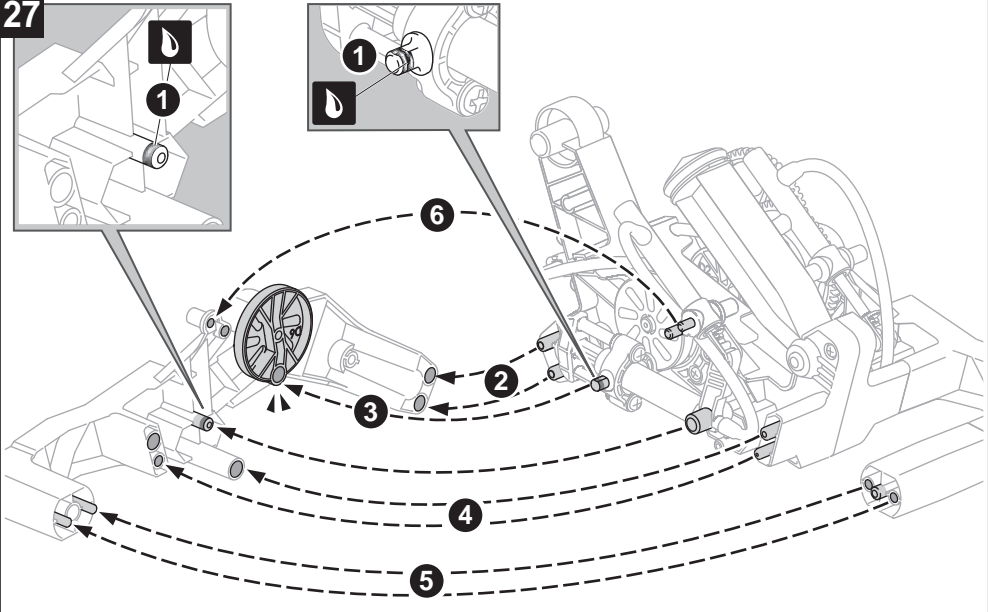

28

P1x5

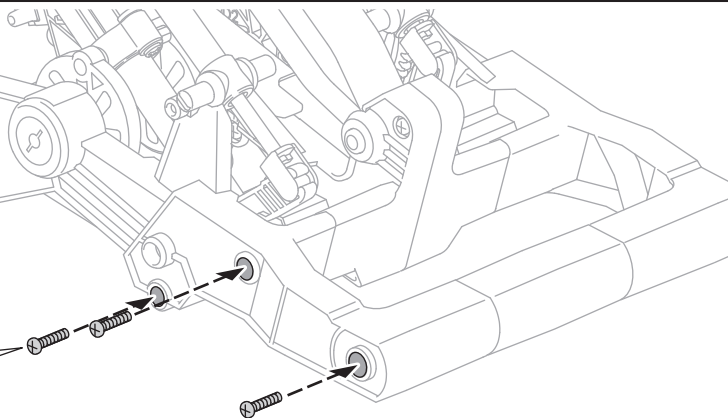
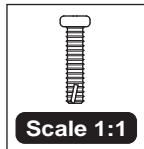

29

Top View

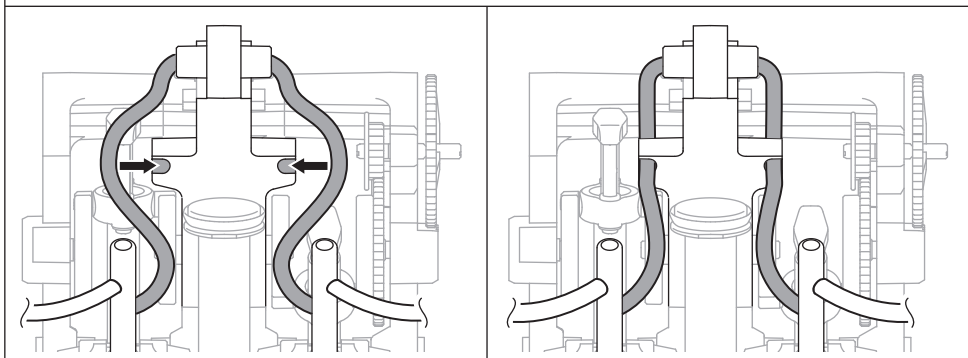

✗
Incorrect

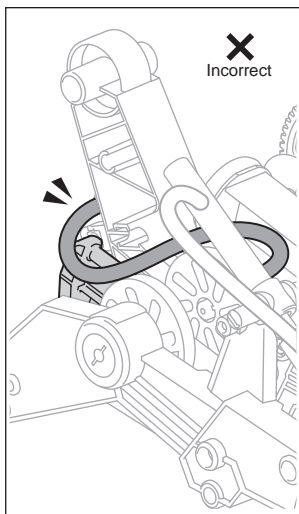

✓
Correct

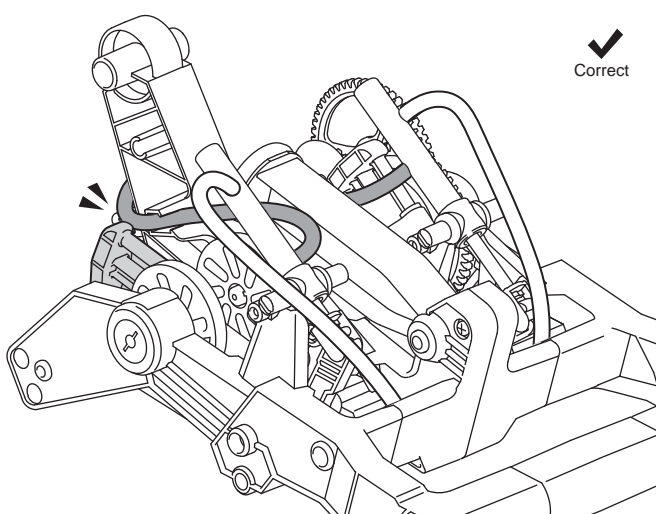

30

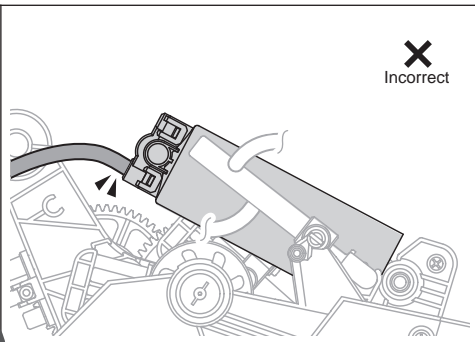
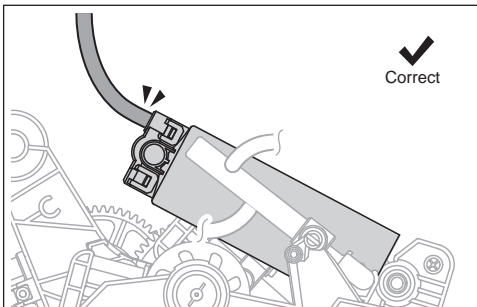
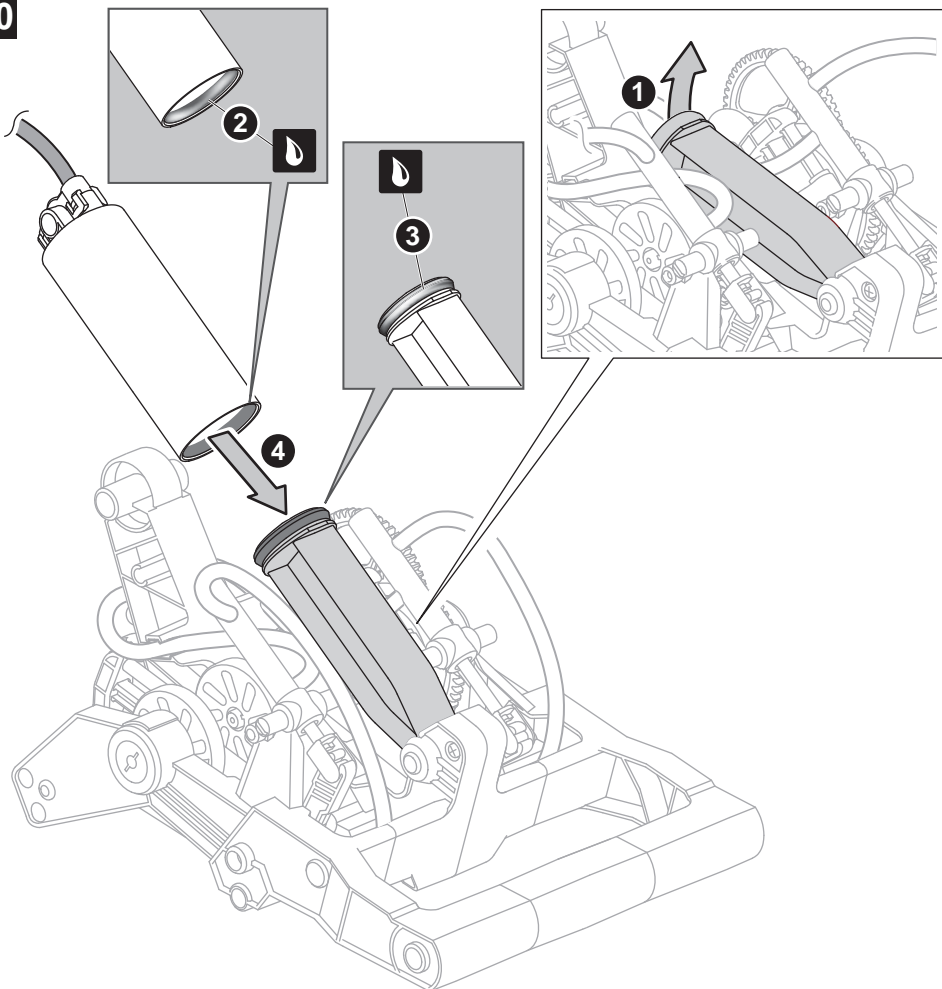

Ensure the correct direction of air tube.

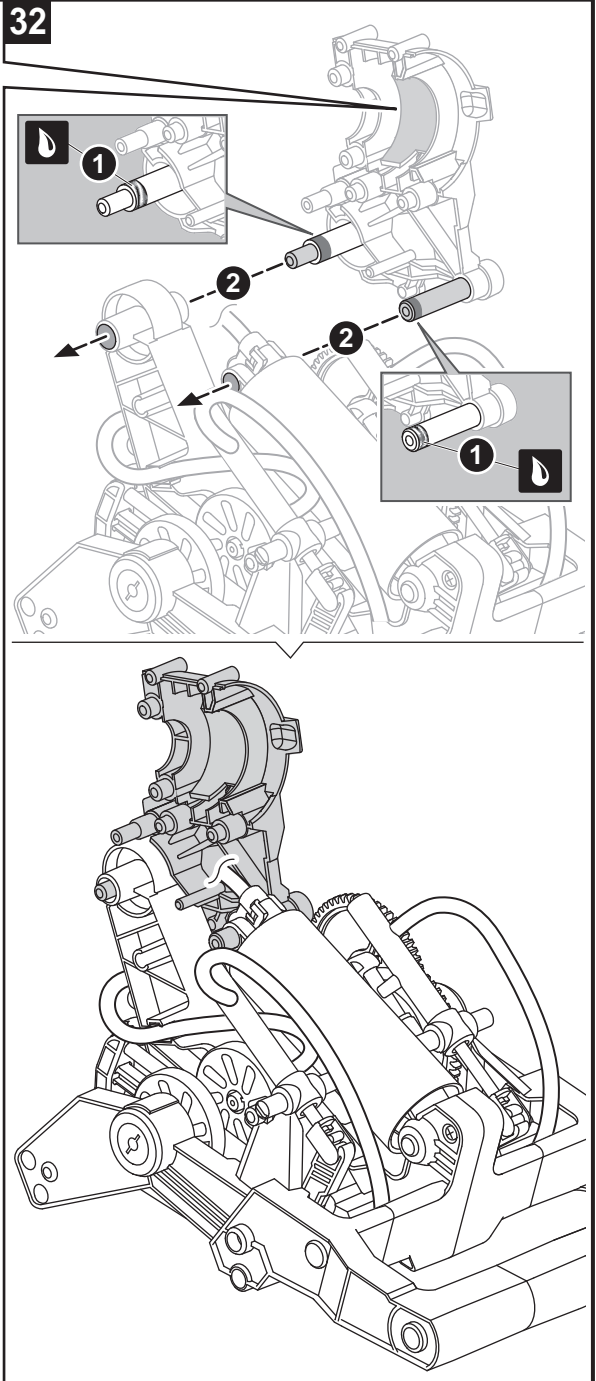
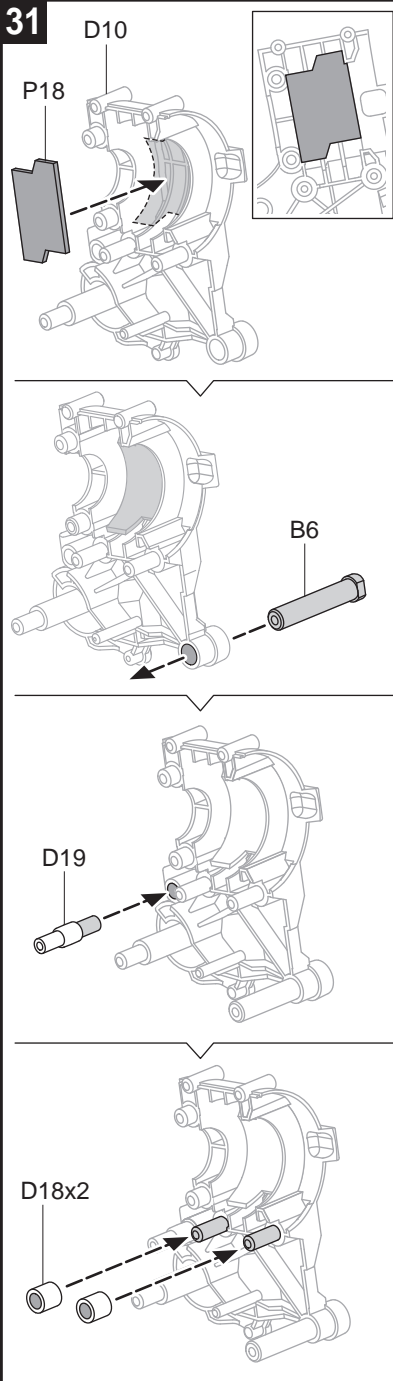

33

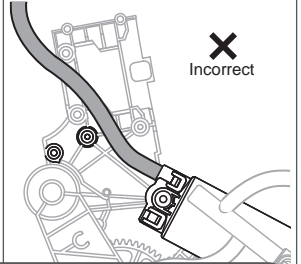
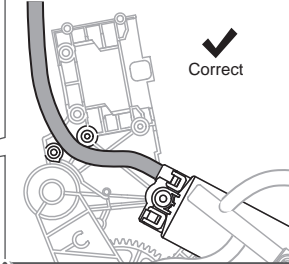
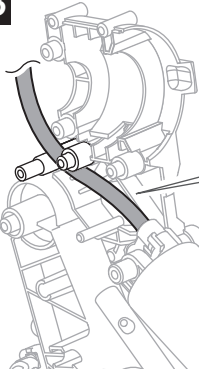

Make sure air tube is installed at a right position as shown above. If positioned wrong, air tube may fail to pump.

34

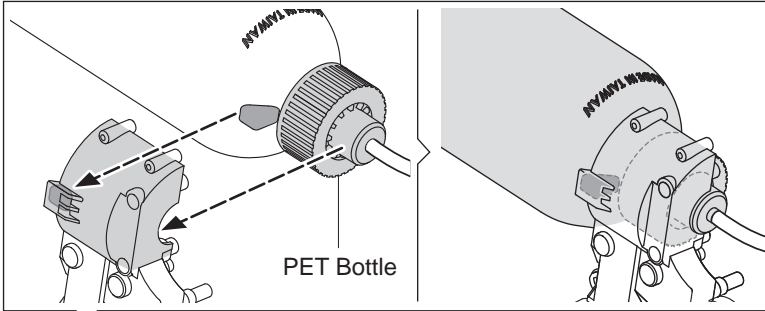

✓
Correct

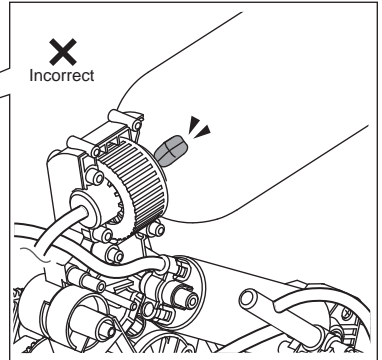
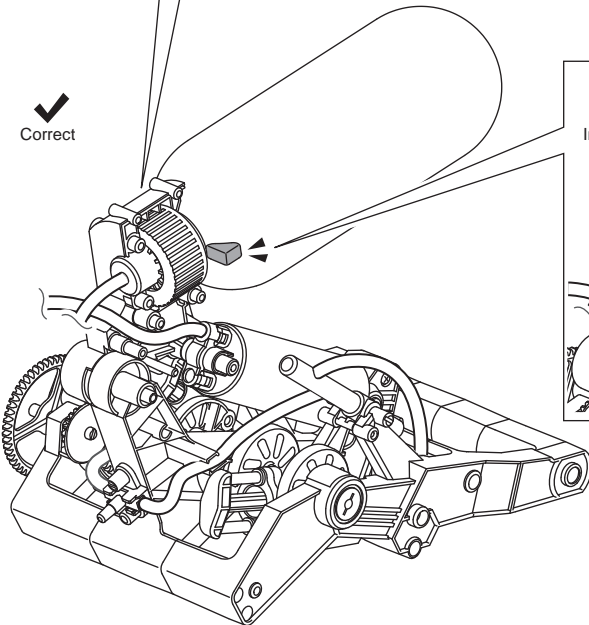

35

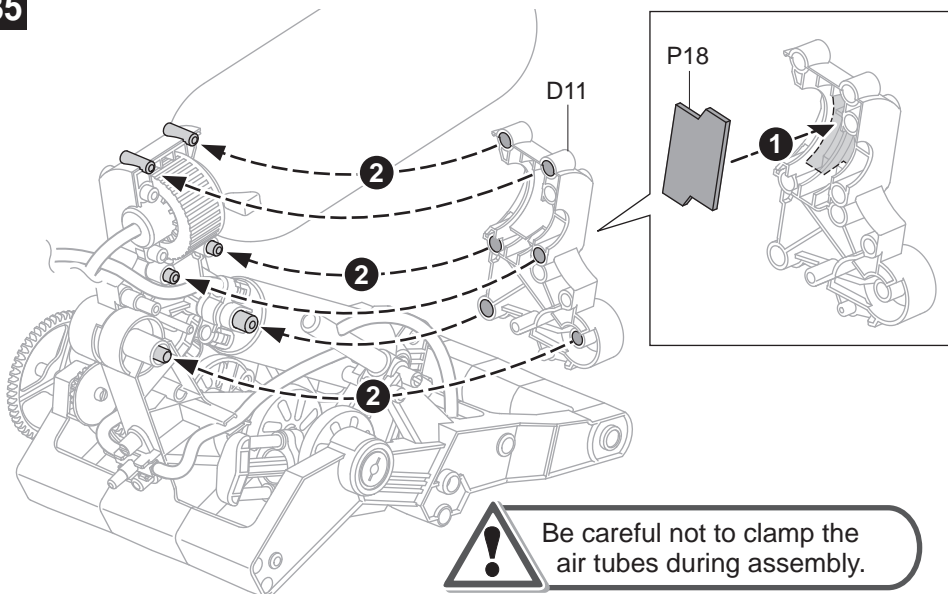

36

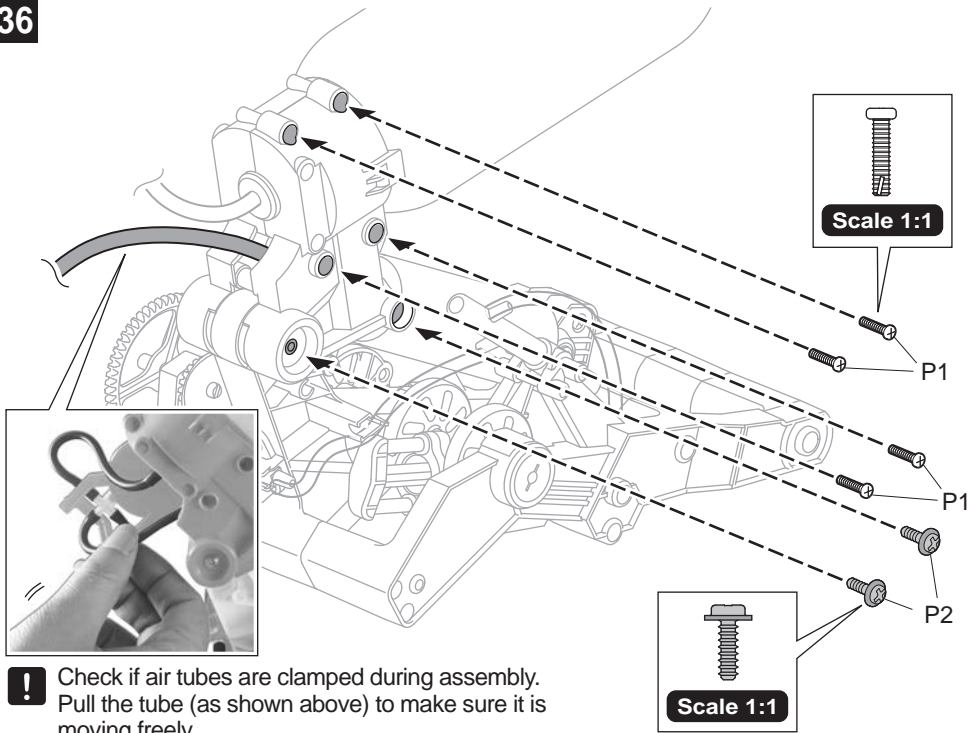

37

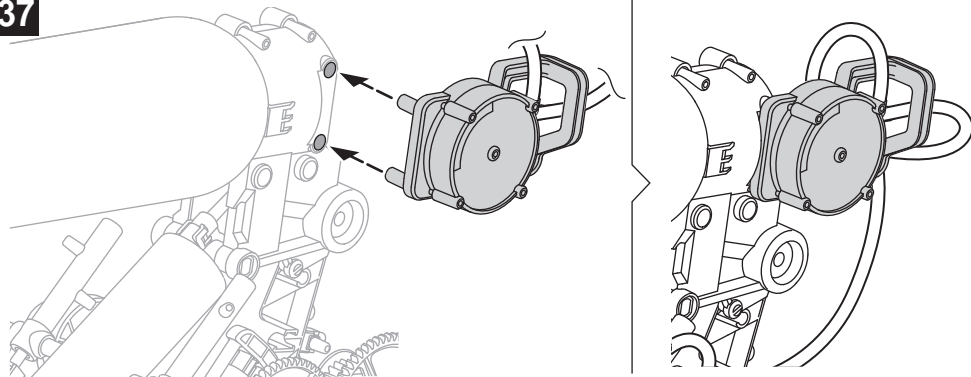

38

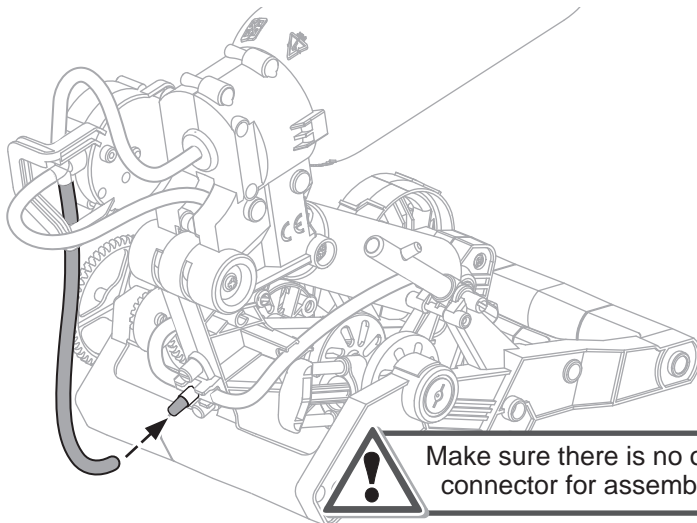

39

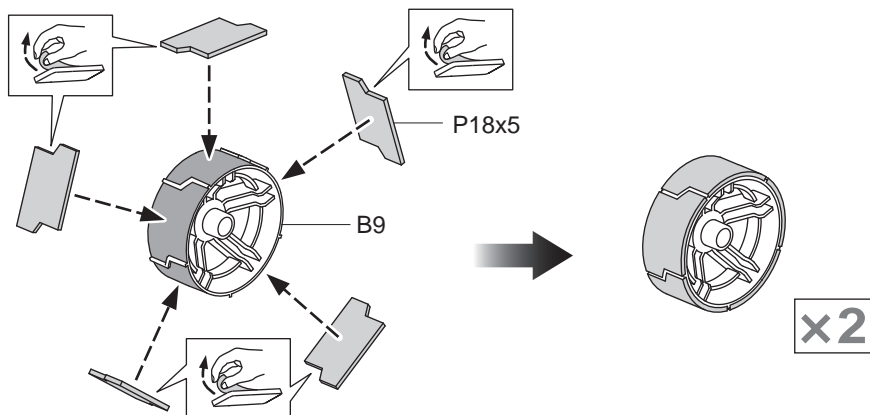

40

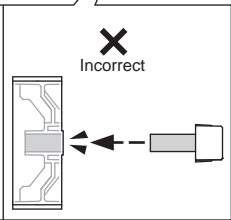
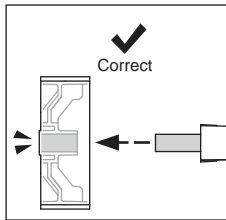
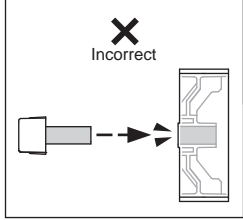
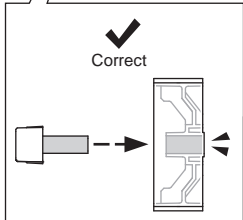
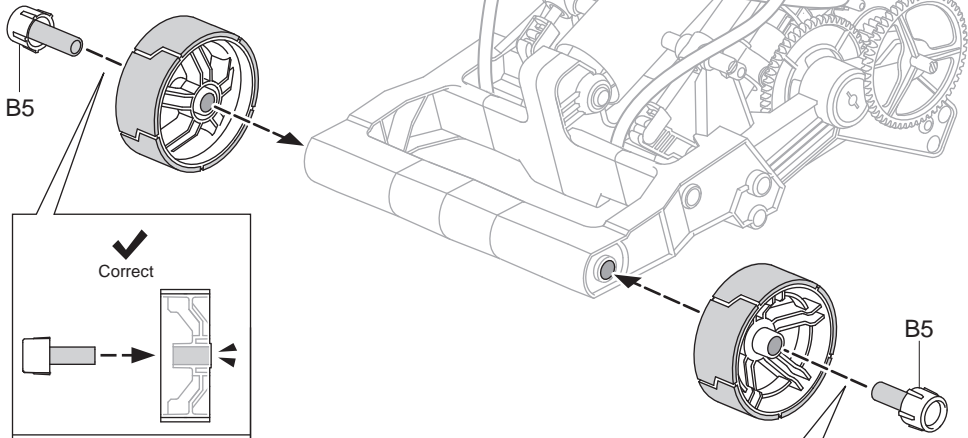

41

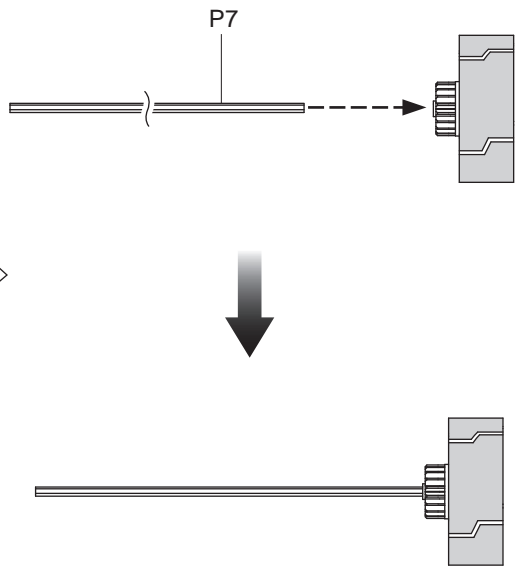
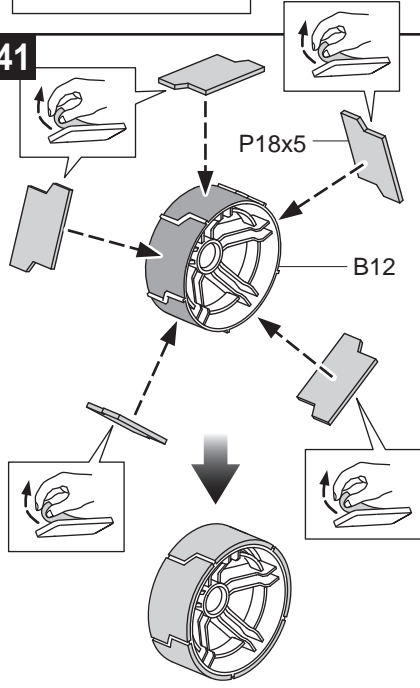

42

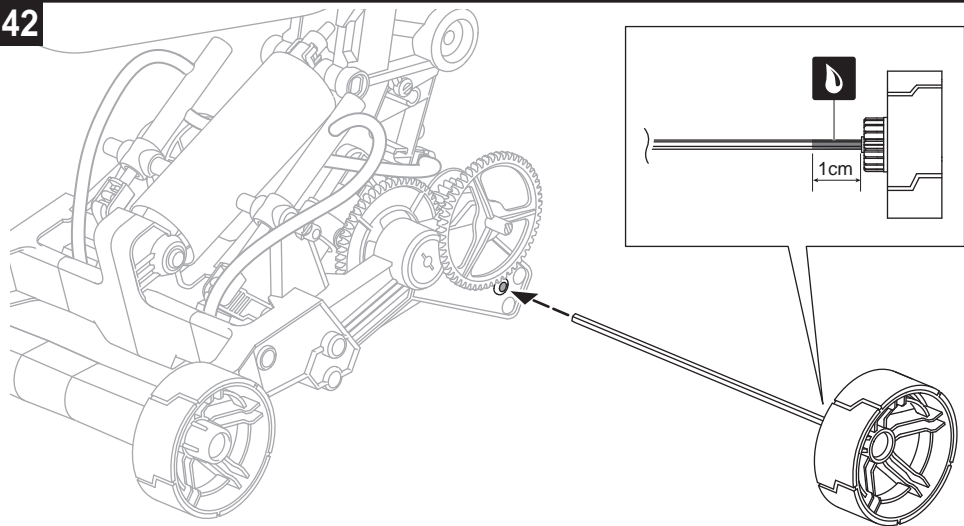

43

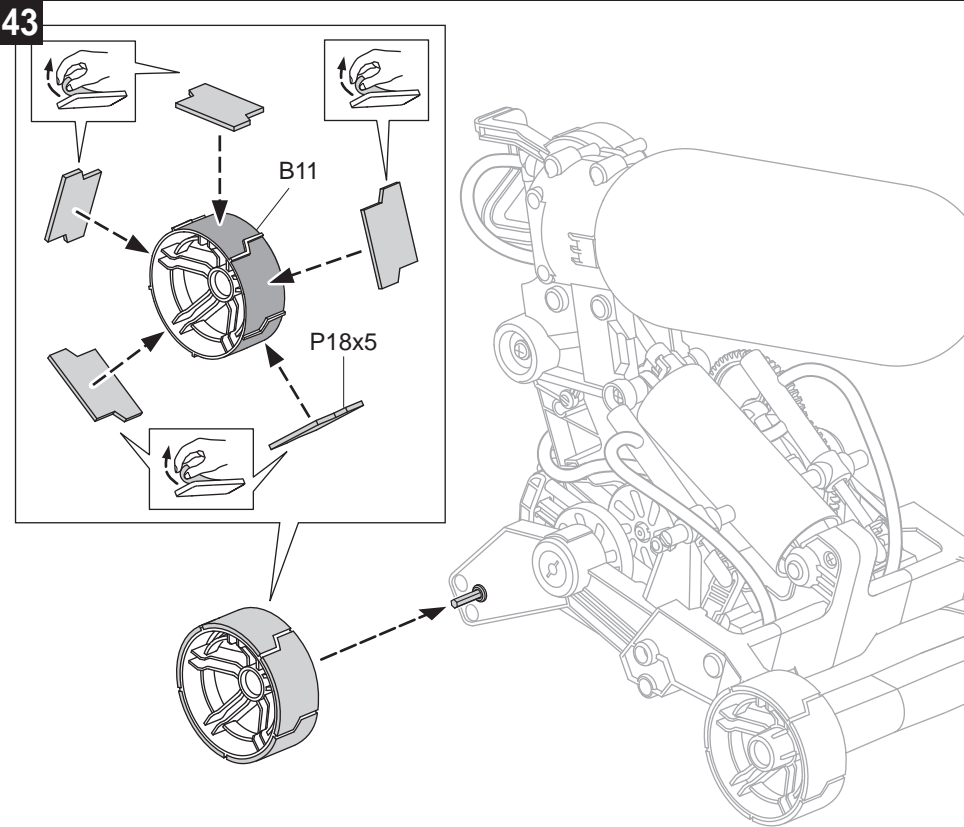

44 Finib ed

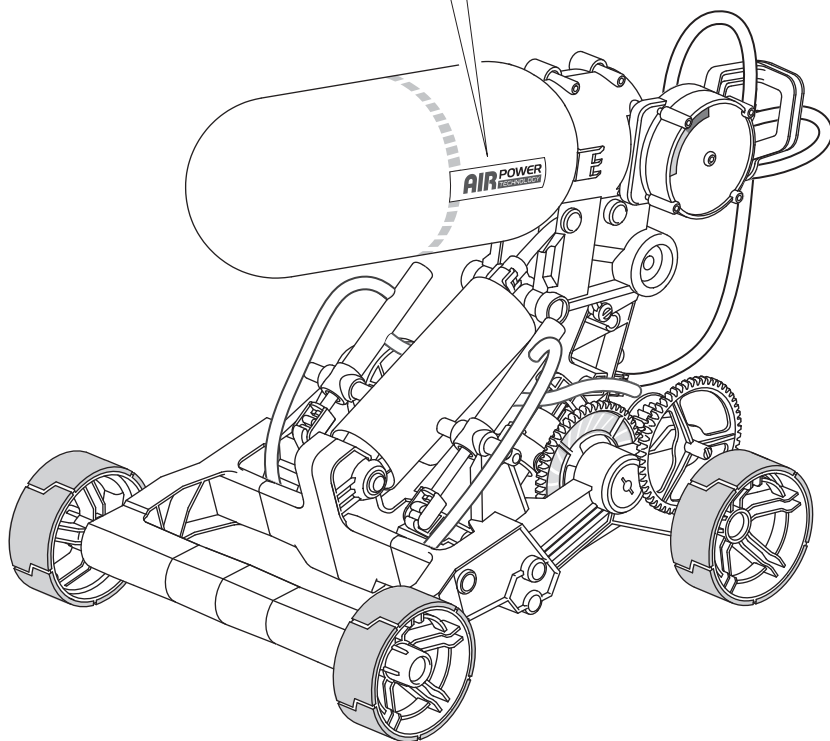
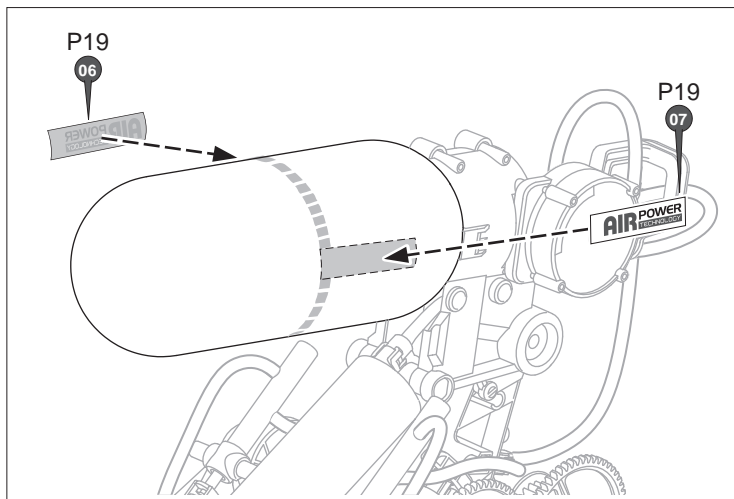

How To Play

1. Spin the rear wheel (as below) to release air completely.

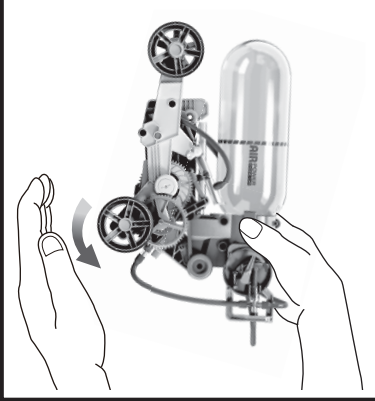

2. Rotate the rear wheel and have the "▽" align to the protrusion on bar (as below), then start to pump.

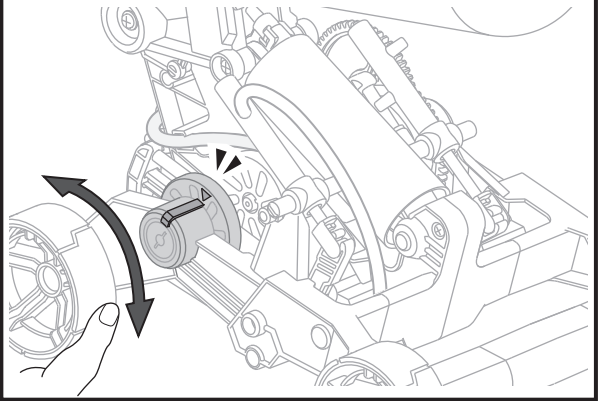

3. Pumping as below figures.

! In the beginning, pump up at least 20 times to start.
(To obtain the best results, do not stop pumping until pressure meter means red and pointed to the red range.)

1

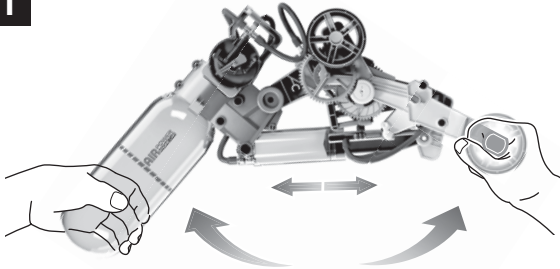

2

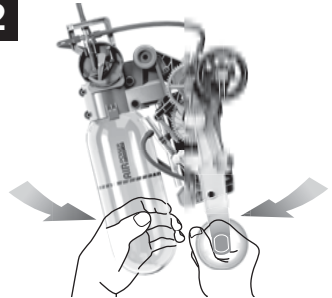

As an equipped safety device, excess air will be automatically released once pressure meter is in the "red" range.

3

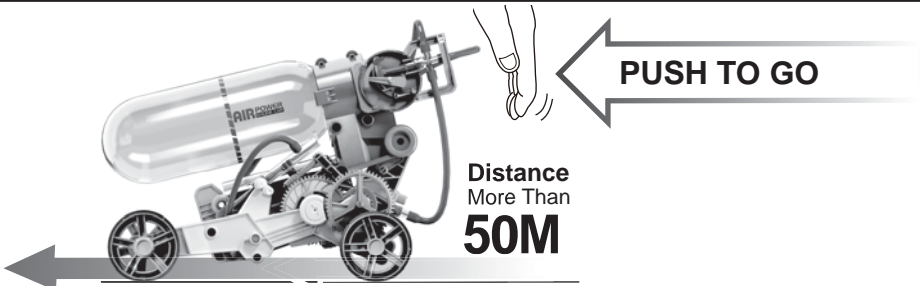

Trouble Shooting

1 Check if pressure meter can not gauge to red range, or if air leaks from anywhere.

1-1 Check if air tubes are installed correctly. (Below marked positions to help you quick check the air tubes, for exact assembly steps - refer to page 4 “ How To Fit Air Tube ”)

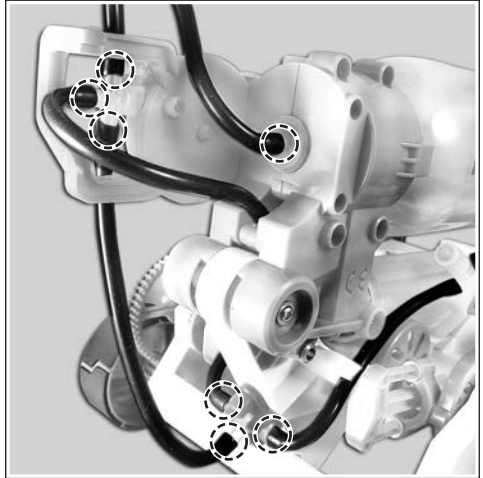
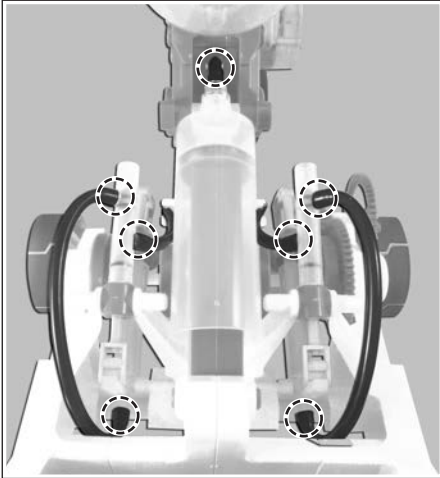

1-2 Check if D9,A2 / D14, A2 are loose..
(refer to page 24, step 15 & page 29, step 22)

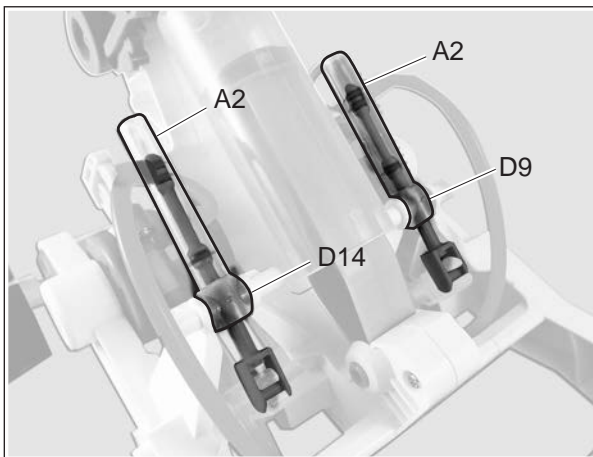

1-3 Check if P10 & D16 are installed correctly. (refer to page 10, step 7)

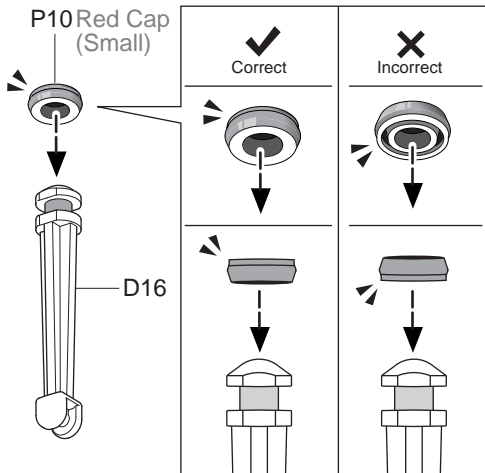
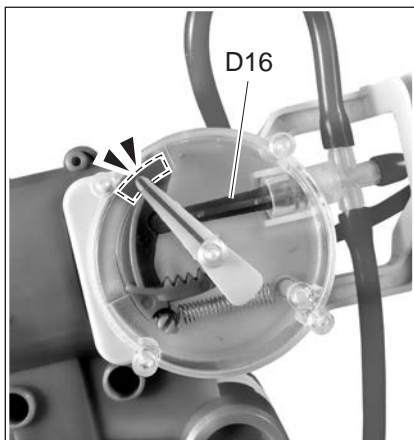

1-4 Check if P14 is fastened tightly. (refer to page 8, step 5)

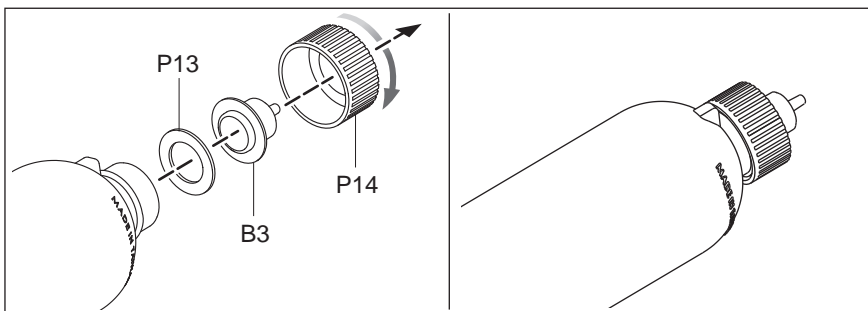

1-5 Check if E2 / A3 are loose. (refer to page 12, step 4)

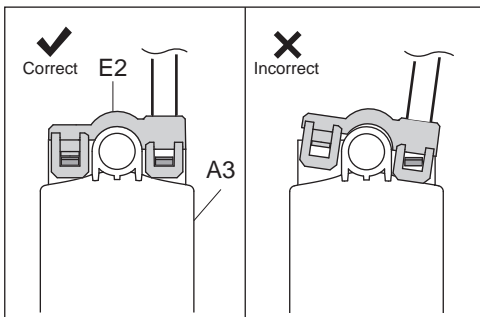
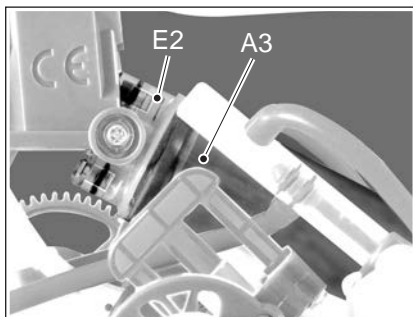

1-6 Check if P9 (O-ring) is seated flat. (refer to page 12, § ep 6)

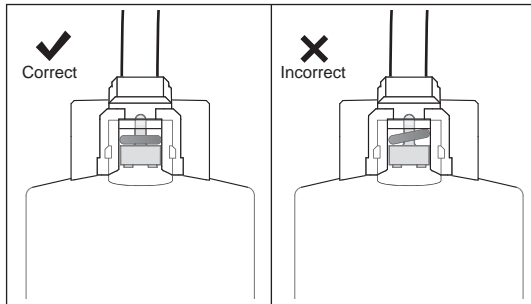
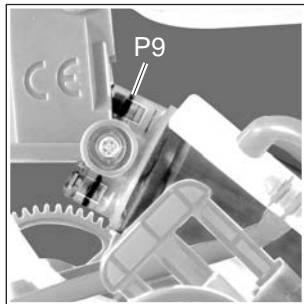

1-7 Check if P17 is installed in the right direction. (refer to page 12, § ep 3)

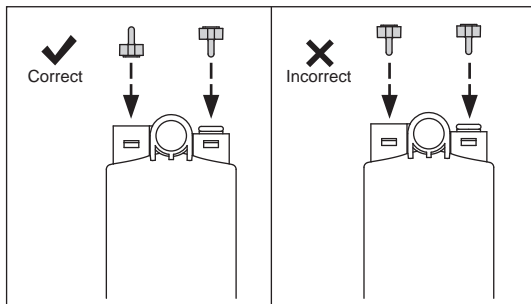
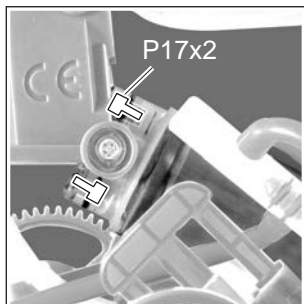

1-8 Check if P10/ B13 are installed in the correct direction. (refer to page 22, § eps 11~13)

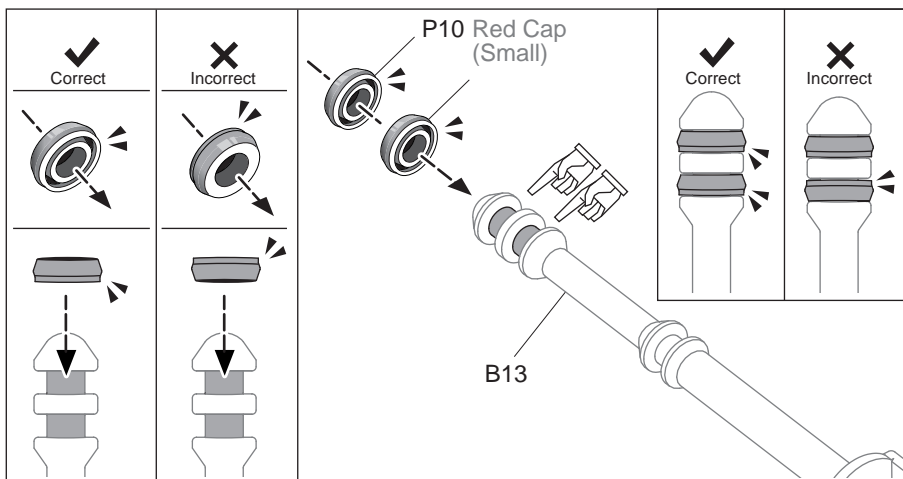

✓
Correct

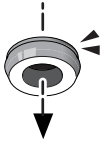

✗
Incorrect

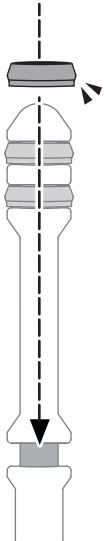
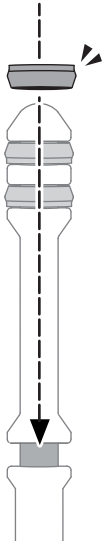
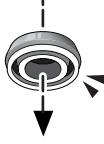

P10
Red Cap
(Small)

B13

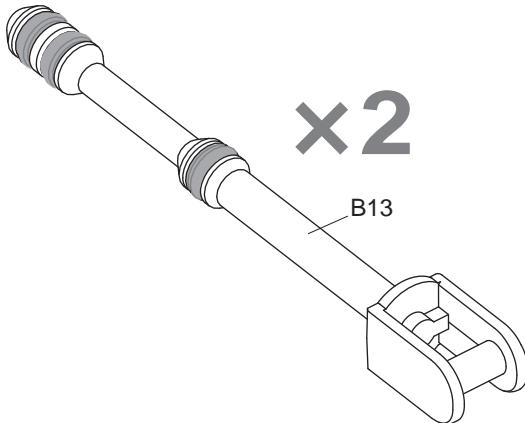
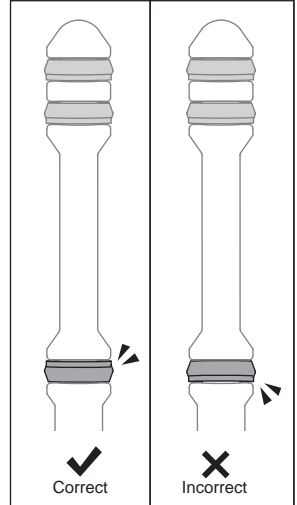
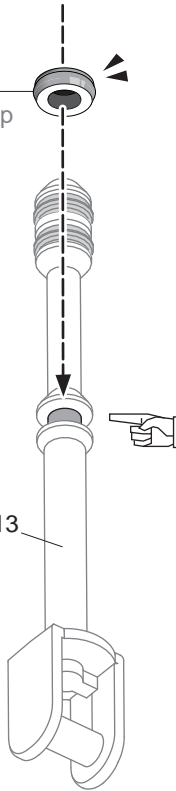

Tip :

Use C5 to adjust if P10 was twisted during assembly.

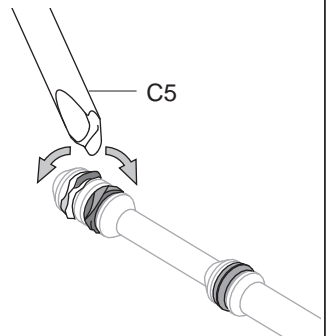

2 If air tubes are loosened while pumping.

2-1 Check if connectors have oil on surface. Take off the connectors/air tubes, make sure to wipe off the oil and use neutral detergent to clean the parts thoroughly.

2-2 Check if air tubes are kinked or clamped during assembly. Slightly pull the tube (as shown below) to make sure it is moving freely .



3 If the pressure meter does not function while pumping.

3-1 Check if pointer is installed correctly (refer to page 11, step 12)

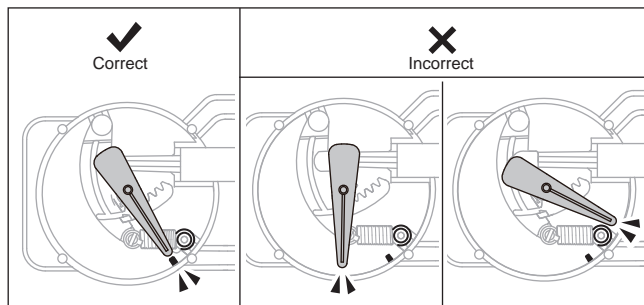

3-2 Check if air tubes are clamped (refer to Trouble Shooting 2-2)

4 Check if D2 / D5 are installed in the right direction. (refer to page17, step 2)

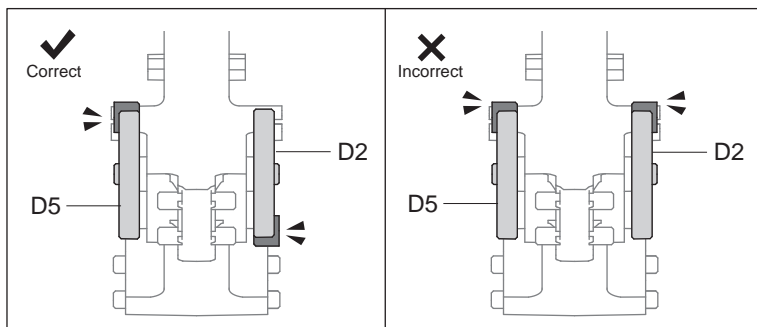

Notes

Notes

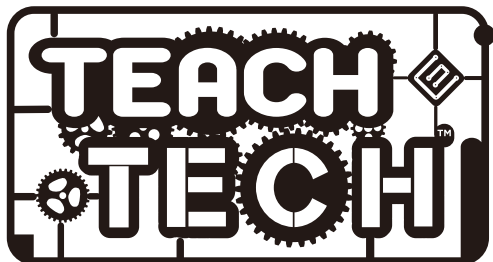

ELENCO®

Learn by doing.™

150 Carpenter Ave.
Wheeling, IL 60090, USA

(847) 541-3800 or (800) 533-2441
elenco.com



CHOKING HAZARD. Small Parts.
Not for children under 3 years old.

No part of this book shall be reproduced by any means: electronic, photocopying,
or otherwise without written permission from the publisher.

Printed in Taiwan

US Patent D762269 S

Not responsible for typographical errors.

Teach Tech™ is a trademark of Elenco Electronics Inc.

Copyright© 2019 Elenco Electronics Inc. All rights reserved.

753182