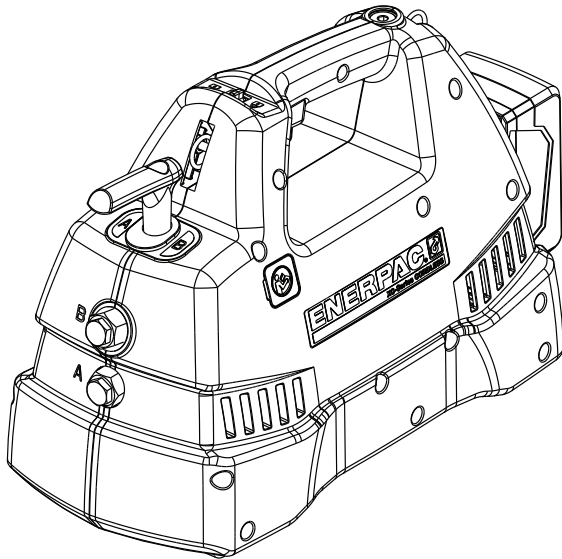
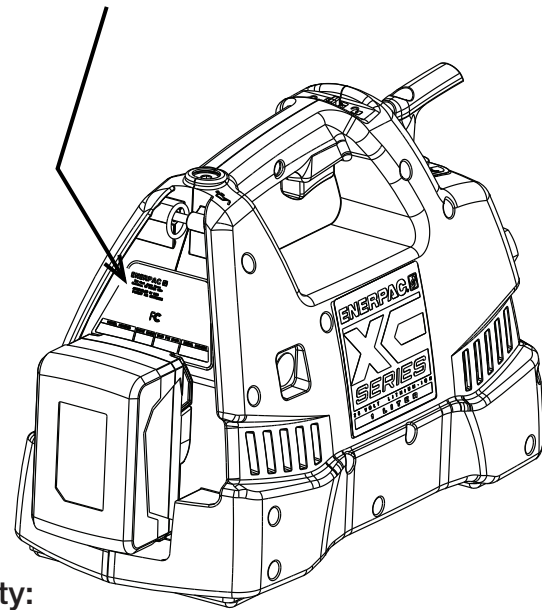


Document Number	Document Revision	Document Revision Date	Product Date Code Beginning With
L4006	C	05/2017	A, B or C



Product Information: Model Number, Serial Number, Maximum Pressure and Date Code.



**IMPORTANT: To maintain your warranty:**

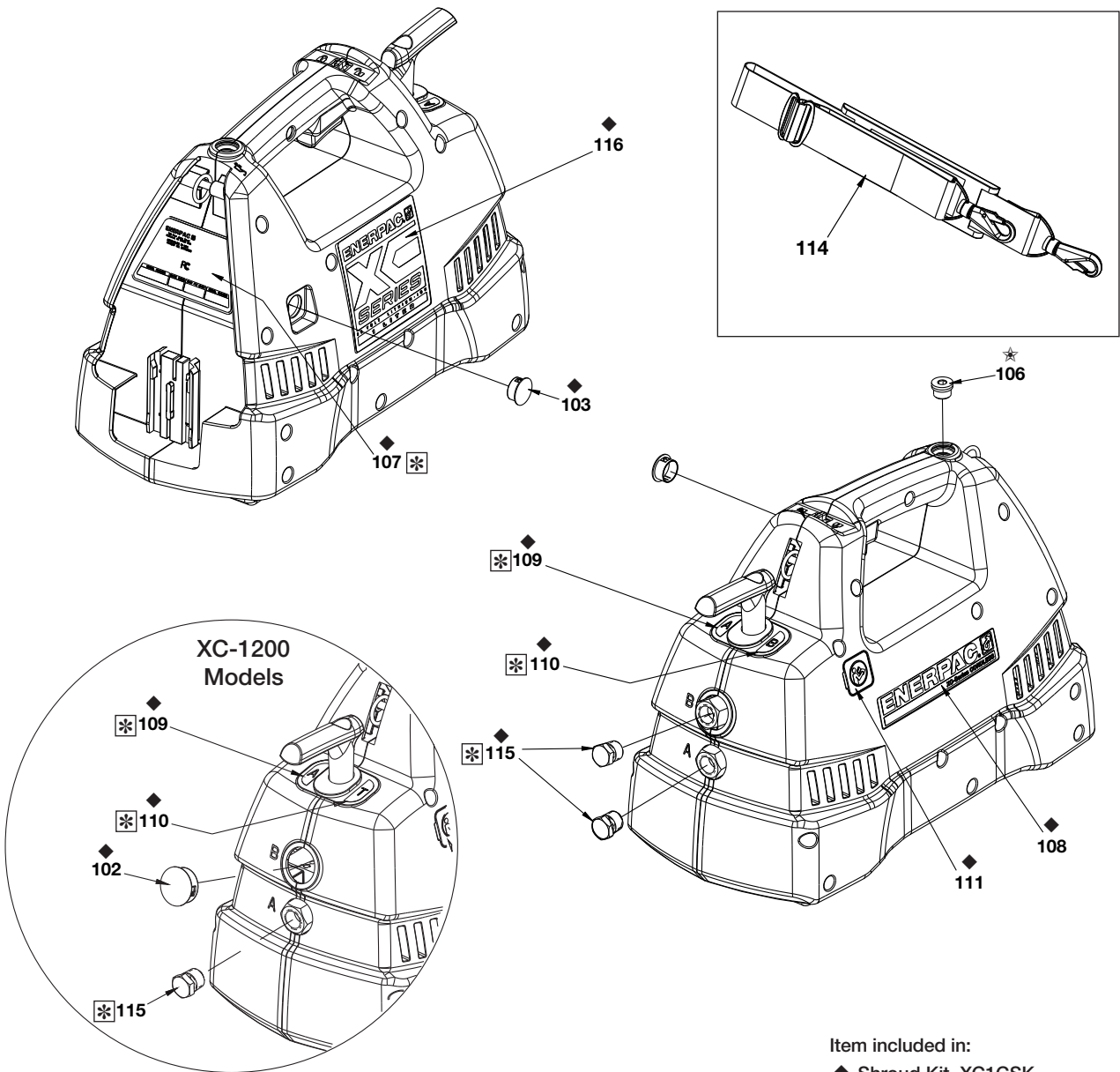
- Use only Enerpac Oil.
- Have your products inspected and repaired by an Enerpac Authorized Service Center.

**Table of Contents:**

	Page		Page
Fig. 1, Decals, Plugs, Caps & Shoulder Strap . . . . .	2	Fig. 9, Control Valve, 4-Way, 3-Position (XC-1400 Models Only) . . . . .	11
Fig. 2, Pump LH Shroud & Hardware . . . . .	3	Fig. 10, Valve Cover Assembly, 4-Way, 3-Position Control Valve (XC-1400 Models Only) . . . . .	12
Fig. 3A, Pump RH Shroud & Electrical Components .4		Fig. 11, Eccentric Shaft & Housing Subassembly . . . . .	13
Fig. 3B, Electrical Components, Old Style . . . . .	5	Fig. 12, Eccentric Shaft Subassembly . . . . .	14
Fig. 4, Oil Fill & Vent Lines . . . . .	6	Fig. 13, Pump Assembly . . . . .	14
Fig. 5, Power Unit Assembly . . . . .	7	Fig. 14, Pump Element . . . . .	15
Fig. 6, Release Valve & Eccentric Assembly (XC-1200 Models Only) . . . . .	8	Fig. 15, Battery & Charger . . . . .	16
Fig. 7, Release Valve Subassembly (XC-1200 Models Only) . . . . .	9	Fig. 16A, Electrical Schematic, Date Code A & B . . . . .	17
Fig. 8, Control Valve, 4-Way, 3-Position (XC-1400 Models Only) . . . . .	10	Fig. 16B, Electrical Schematic, Date Code C . . . . .	18
		Service Information . . . . .	19

**⚠ WARNING** Fully relieve hydraulic pressure, remove battery, and disconnect hydraulic hoses before beginning any maintenance, repair or inspection procedures. Failure to observe these precautions could result in death or serious personal injury.

**Fig. 1, Decals, Plugs, Caps & Shoulder Strap**

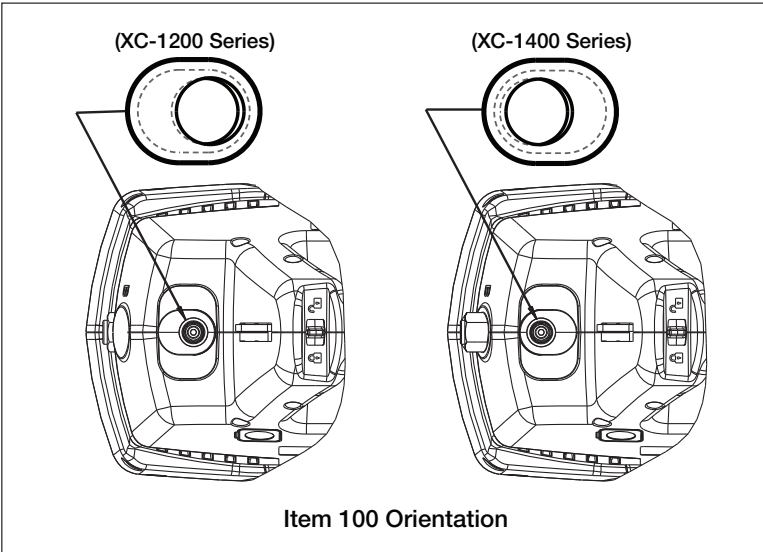
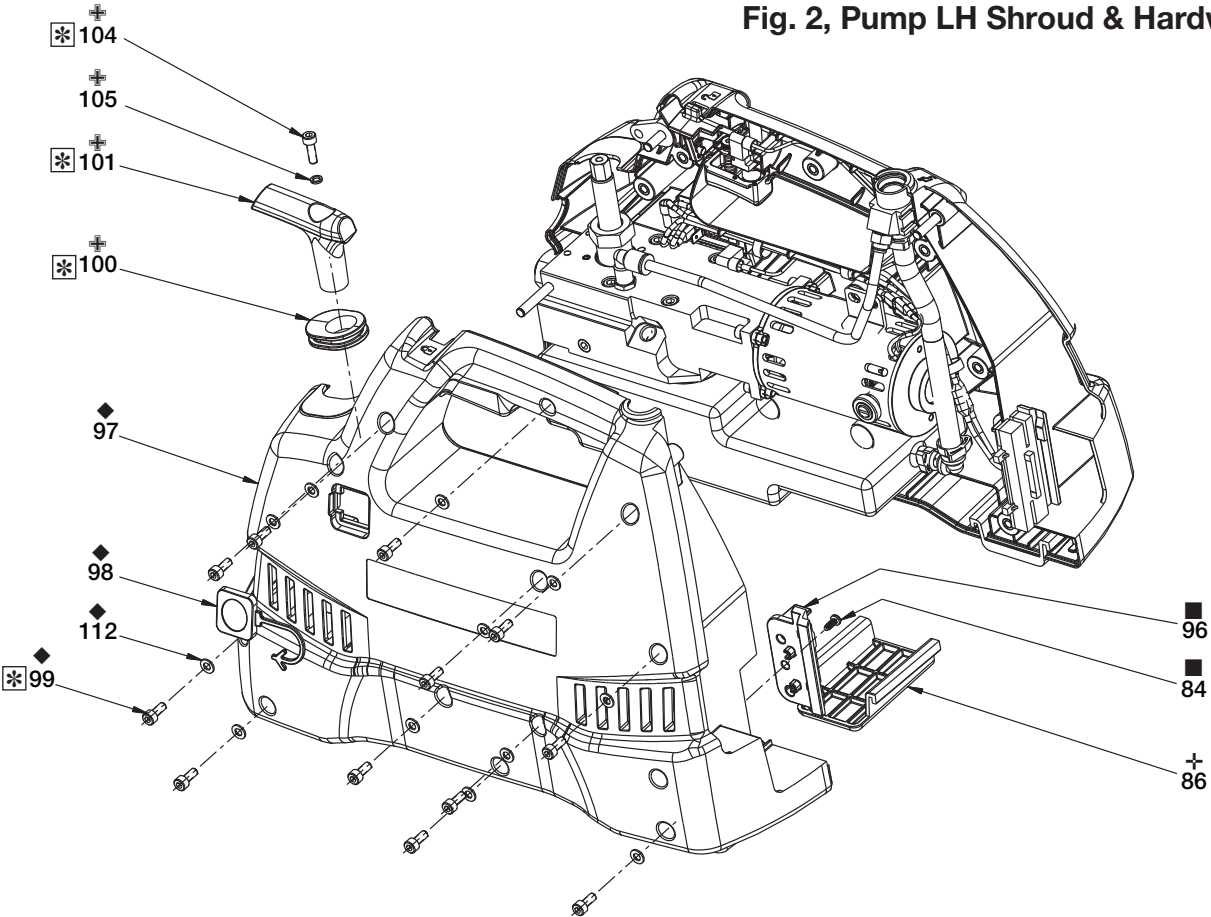


Item included in:  
 ◆ Shroud Kit, XC1CSK  
 ☆ Oil Fill Service Kit, XC1VFK

Repair Parts List, Fig. 1							L4006
Item	Part Number	Qty.	Description	Item	Part Number	Qty.	Description
102	◆ DD4112009	1	Plug, 28 mm (XC-1200)	111	◆ DC7887026	1	Label, Read Instructions
103	◆ DD4110009	1	Dome Plug, 19 mm	114	DD3418528	1	Strap, Shoulder
106	☆ DD3948006	1	Plug, SAE #6 Int. Hex.	115	R515245-2	1	Plug (XC-1200)
107	◆ DD3410026	1	Decal, Product Spec XC	115	R515245-2	2	Plug (XC-1400)
108	◆ DD3409026	1	Decal, Enerpac XC	116	◆ DD4023026	1	Decal, XC Classic 1L
109	◆ DD3937026	1	Decal, "A", XC Pump	116	◆ DD4241026	1	Decal, XC Classic 2L
110	◆ DD3938026	1	Decal, "T", (XC-1200)				
	◆ DD5577026	1	Decal, "B", (XC-1400)				

**IMPORTANT:** Shaded items are available only in kits (not sold separately).

Fig. 2, Pump LH Shroud & Hardware



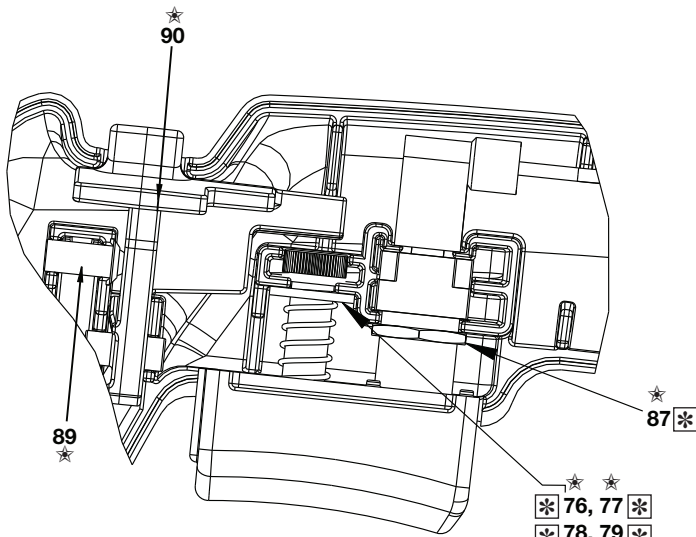
- Item included in:
- ◆ Shroud Kit, XC1CSK
  - + Rubber Foot Kit, XC1FK
  - Battery Guide Kit, XC1BGK
  - + Handle Kit, XC1VHK



Repair Parts List, Fig. 2							L4006
Item	Part Number	Qty.	Description	Item	Part Number	Qty.	Description
84	■ DD3883028	1	Screw, M4 x 10 TRX	100	+ DD3888808	1	Grommet, Valve
86	+ DD3414339	2	Foot, Rubber	101	+ DD3398070	1	Handle
96	■ DD3420101	1	Battery Plate, LH	104	+ CBE517028-1A	1	Screw
97	◆ DD3405424	1	Shroud, LH	105	+ B1086066	1	Washer
98	◆ DD3408098	1	Cap, UARV	112	◆ CAE1050108-1A	12	Washer
99	◆ CBE517028-1A	12	SHCS, M5 x 12 Zinc				

IMPORTANT: Shaded items are available only in kits (not sold separately).

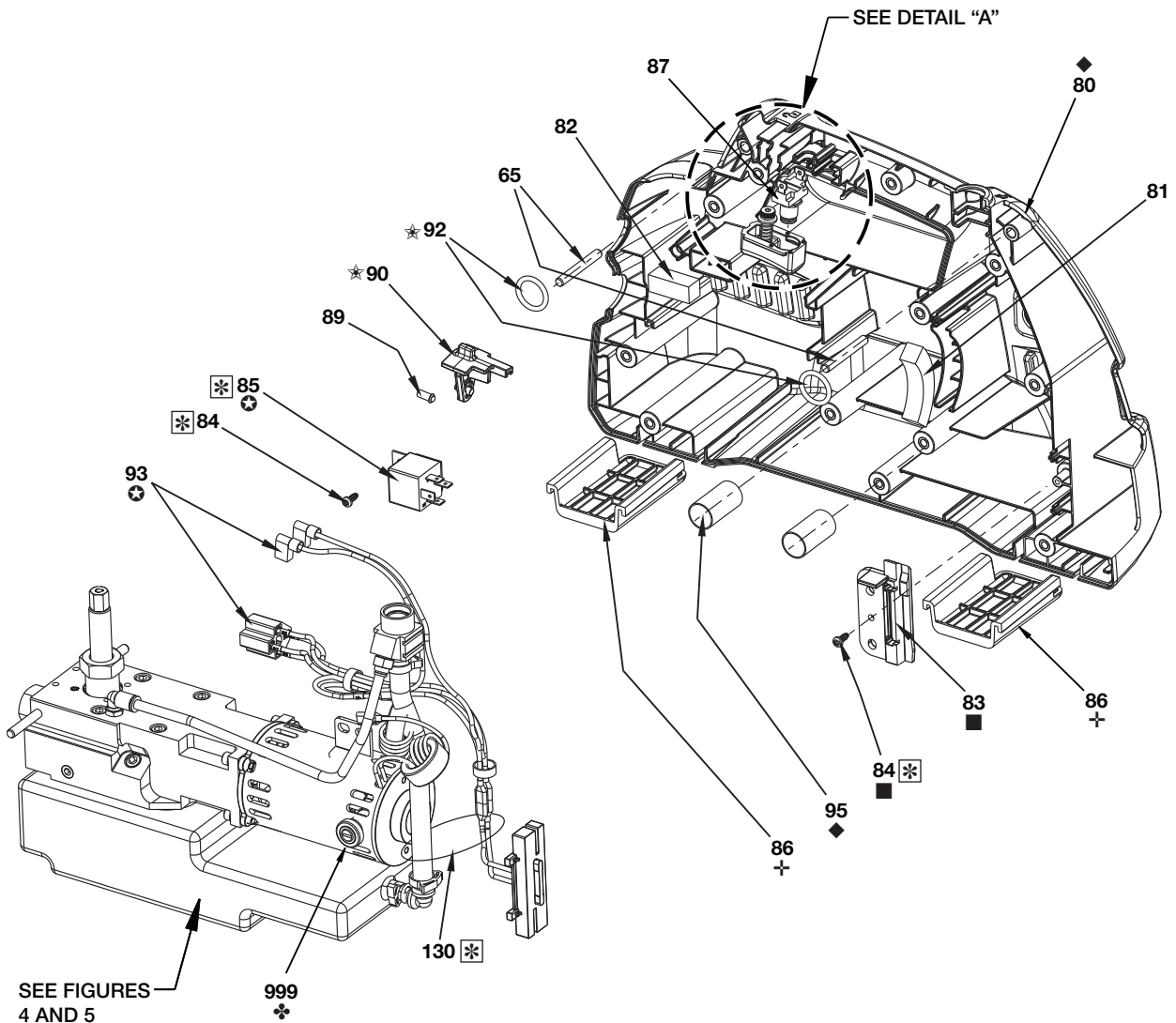
**Fig. 3A, Pump RH Shroud & Electrical Components**



**DETAIL "A" - SWITCH AND TRIGGER**

Item included in:

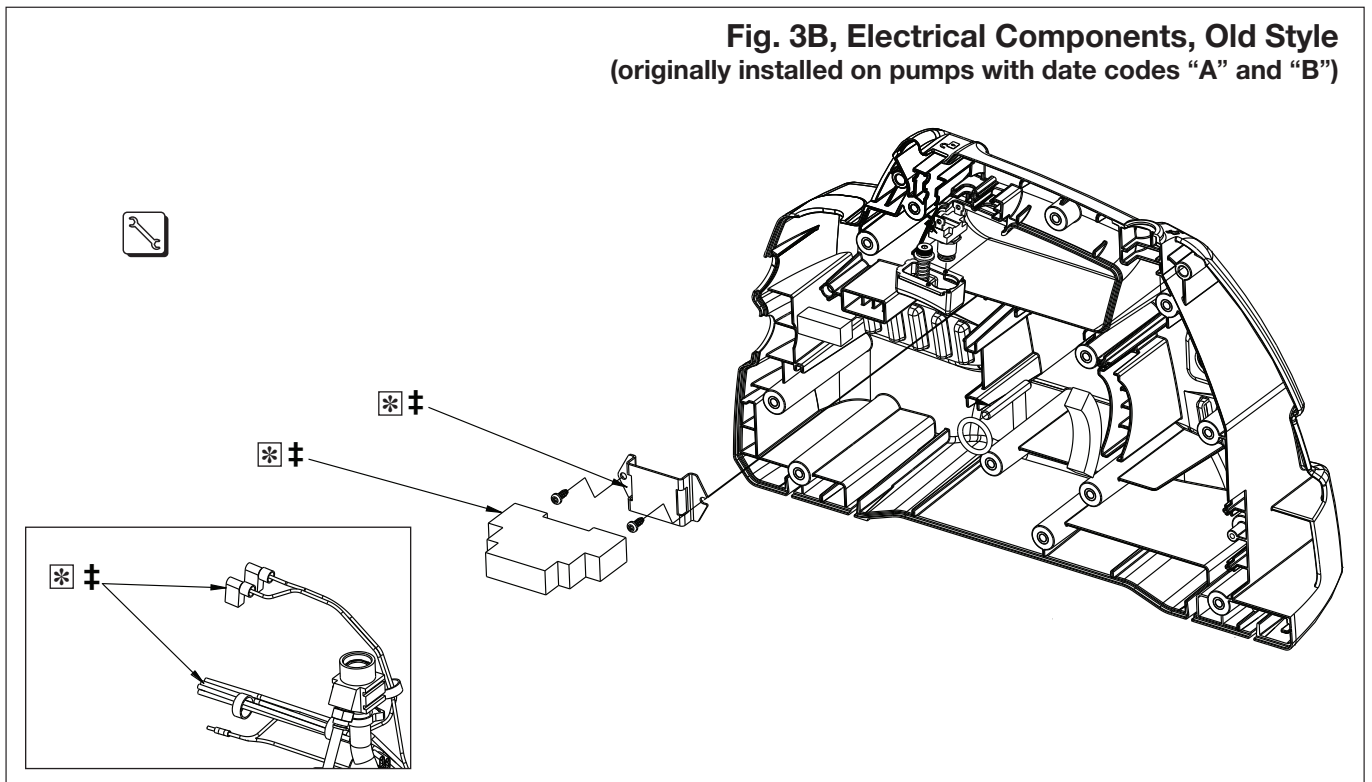
- + Rubber Foot Kit, XC1FK
- ★ Trigger Assembly, XC1TRK
- ◆ Shroud Kit, XC1CSK
- Battery Guide Kit, XC1BGK
- ⊕ Motor Brush Kit, XC1MBK
- ⊗ Harness & Relay Kit, DD6094380K



Repair Parts List, Fig. 3A			L4006
Item	Part Number	Qty.	Description
65	DD3417059	2	Pin, 6 mm x 45 mm Long
76	★ DD4114098	1	Cover, Trigger Switch (with insert)
77	★ DD3407110	1	Spring, Trigger
78	★ B1088108	1	Washer
79	★ DD4109028	1	Screw, Shoulder, 0.25 Dia.
80	◆ DD3406424	1	Shroud, RH
81	DD4113339	2	Bumper, Motor Isolator (one per shroud)
82	DD3887339	2	Bumper, Pump Isolator (one per shroud)
83	■ DD3426101	1	Guide, RH Battery Lock
84	■ DD3883028	1	Screw (secures item 83 to RH shroud)
84	DD3883028	1	Screw (secures item 85 to RH shroud)
85	⊕ DD6094380	1	Relay, 60 Amp, 24VDC
86	† DD3414339	2	Foot, Slide
87	★ DD3423379	1	Switch, On-Off, Momentary
89	★ DD3421013	1	Safety Detent
90	★ DD2998098	1	Safety Switch
92	DD4769667	2	Ring, Round
93	⊗ DD6095960	1	Wiring Harness
95	◆ DD3886268	2	Sleeve
130	DC9876647	1	Cable Tie, 6"
999	❖ Order Kit XC1MBK	1	Motor Brush Kit (each kit includes two brushes and two brush caps)

**IMPORTANT:** Shaded items are available only in kits (not sold separately).

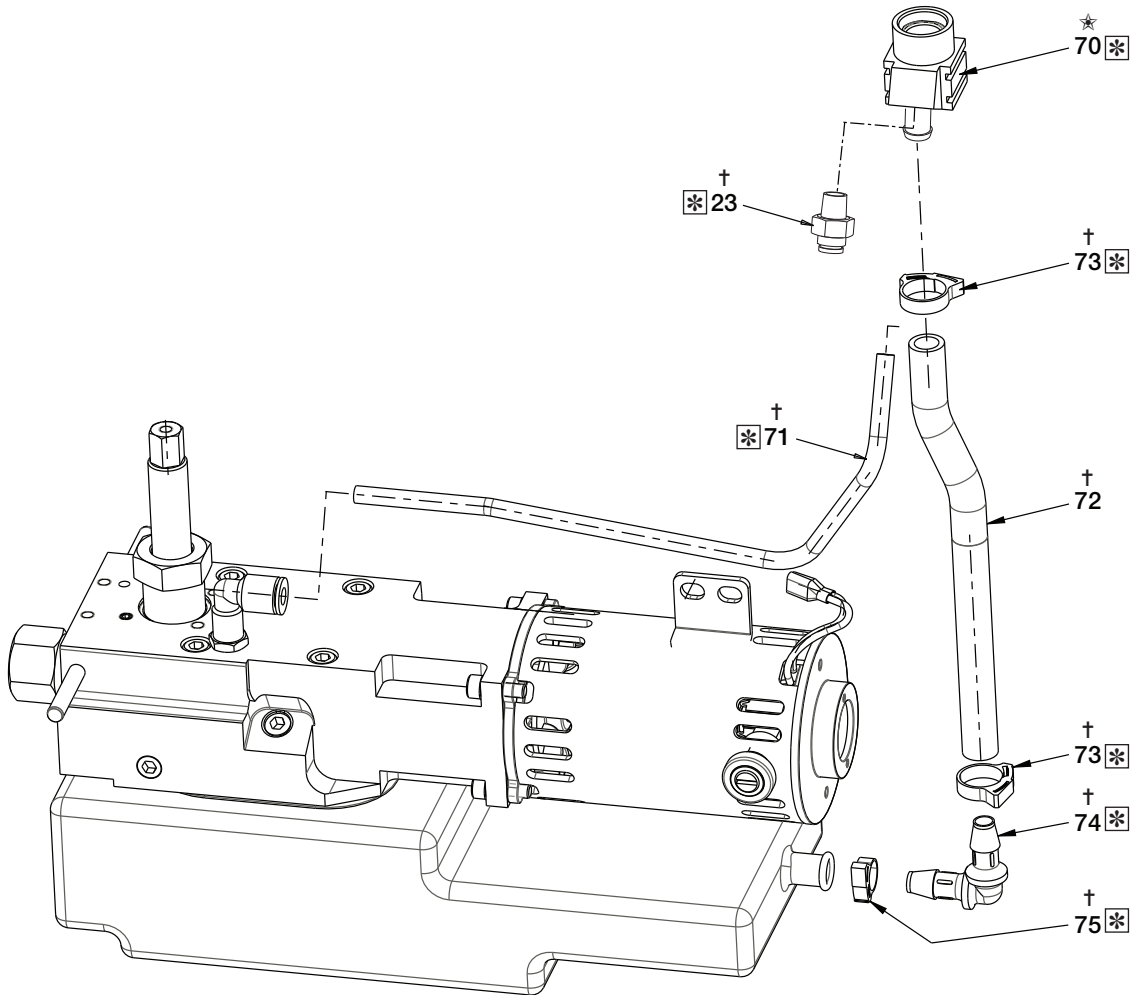
**Fig. 3B, Electrical Components, Old Style**  
(originally installed on pumps with date codes "A" and "B")



**Fig. 4, Oil Fill & Vent Lines**

Item included in:

- † Oil Fill Tubing Kit, XC1TK
- ★ Oil Fill Service Kit, XC1VFK



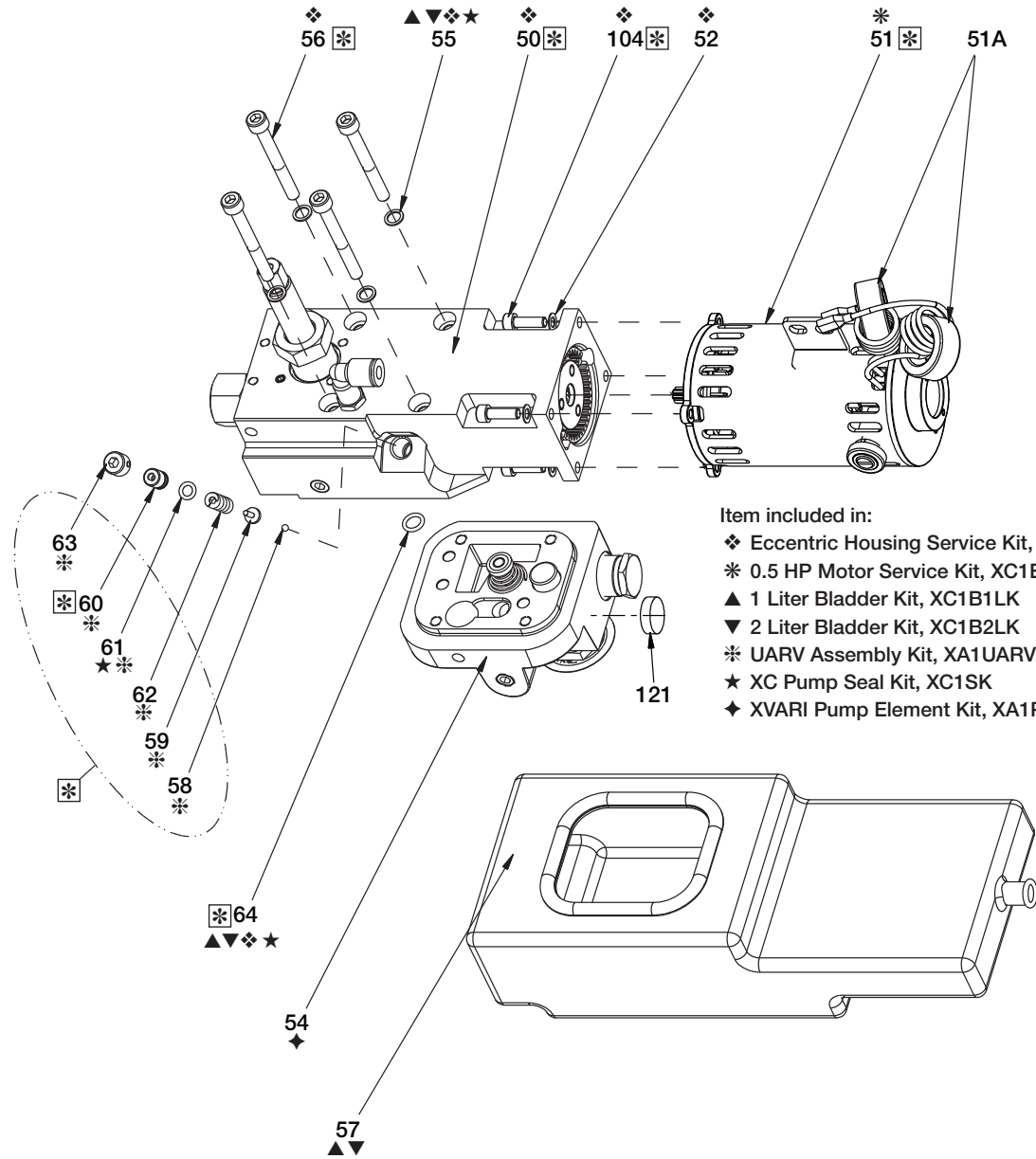
**Repair Parts List, Fig. 4**

**L4006**

Item	Part Number	Qty.	Description	Item	Part Number	Qty.	Description
23	† F100097-33	1	Fitting	73	† DD4118017	2	Clip, Oil Fill, Reusable
70	★ DD3403900	1	Fill Assembly, Vented	74	† DD3416097	1	Elbow, Barbed 0.38"
71	† DD4108646	1	Tube, Oil Vent	75	† DD3885017	1	Clip, Reusable 0.38"
72	† DD3415646	1	Tube, Oil Fill				

**IMPORTANT:** Shaded items are available only in kits (not sold separately).

**Fig. 5, Power Unit Assembly**

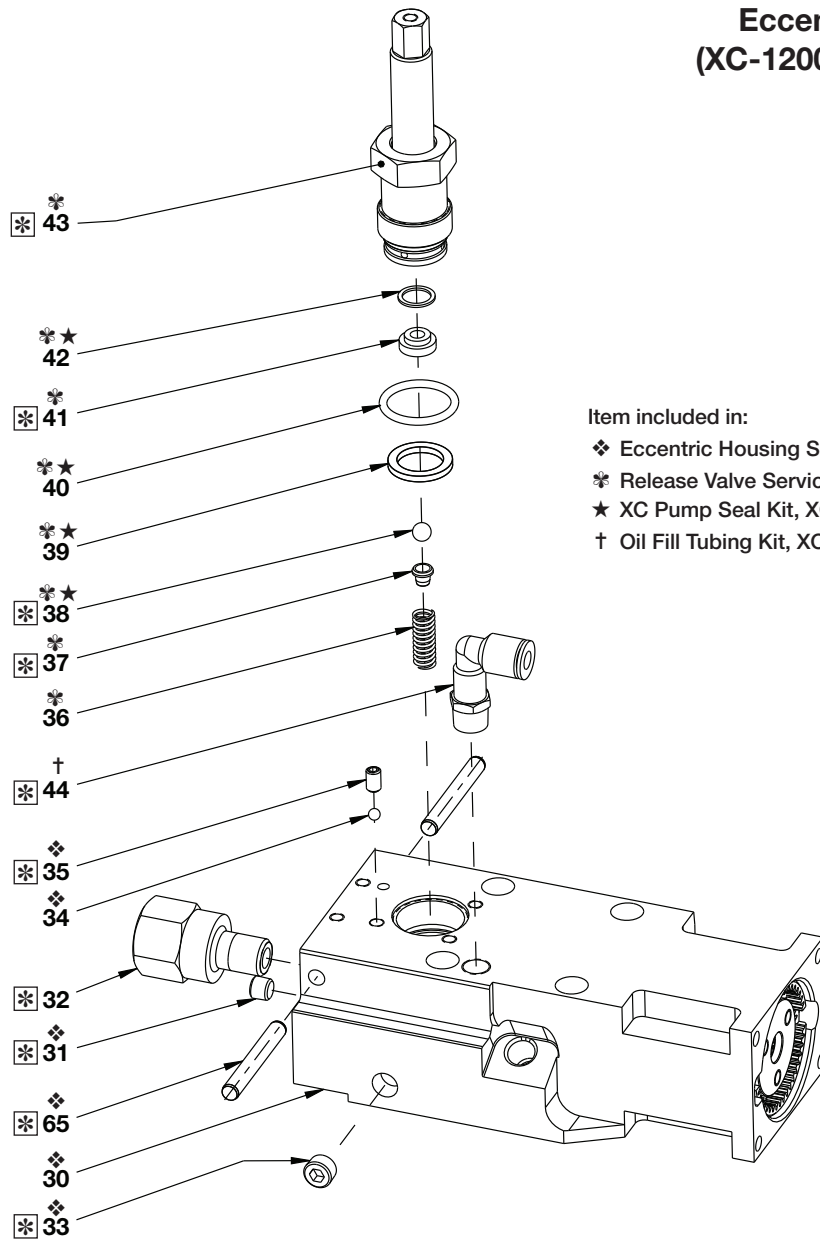


- Item included in:
- ◆ Eccentric Housing Service Kit, XC1ECK
  - \* 0.5 HP Motor Service Kit, XC1EMK
  - ▲ 1 Liter Bladder Kit, XC1B1LK
  - ▼ 2 Liter Bladder Kit, XC1B2LK
  - \* UARV Assembly Kit, XA1UARVK
  - ★ XC Pump Seal Kit, XC1SK
  - ◆ XVARI Pump Element Kit, XA1PEK

Repair Parts List, Fig. 5							L4006
Item	Part Number	Qty.	Description	Item	Part Number	Qty.	Description
50	(See Fig. 6)	1	(not sold as subassembly)	58	* B1003016	1	Ball, 1/8" Diameter
51	* DD2993259	1	Motor, PMDC 28VDC	59	* A8038570	1	Ball Cap
51A	DD4406380	1	Cores (included with 51)	60	* DC7234009	1	Plug
52	◆ CCE1050108-6A	4	Lock Washer	61	*★ B1004503	1	O-Ring
54	◆ (See Fig 11)	1	Pump Element	62	* A8126110	1	Spring, Coil, 2000 lbs.
55	▲▼◆★ S3037	4	Gasket	63	* DC10131048	1	Set Screw, Cup Pt. Nylok
56	◆ CCA635028-1A	4	Screw, SHCS M6 x 55	64	▲▼◆★ B1011803	1	O-Ring
57	▲ DD2995025	1	Bladder, 1 Liter	104	◆ CBE519028-1A	4	Capscrew
	▼ DD2991025	1	Bladder, 2 Liter	121	C187018	1	Magnet

**IMPORTANT:** Shaded items are available only in kits (not sold separately).

**Fig. 6, Release Valve & Eccentric Assembly (XC-1200 Models Only)**



Item included in:

- ❖ Eccentric Housing Service Kit, XC1ECK
- \* Release Valve Service Kit, XC1MVSK
- ★ XC Pump Seal Kit, XC1SK
- † Oil Fill Tubing Kit, XC1TK

**Repair Parts List, Fig. 6**

**L4006**

Item	Part Number	Qty.	Description	Item	Part Number	Qty.	Description
30	❖ (See Fig. 8)	1	Eccentric and Housing	38	*★ B1007016	1	Ball, 1/4" Dia.
31	❖ DC6792245	1	Plug, Flush NPTF .062	39	*★ CL344167	1	Gasket
32	FZ1055	1	Adapter	40	*★ B1118903	1	O-Ring
33	❖ DC6793245	1	Plug, Flush NPTF .125	41	* DC7305290	1	Seat
34	❖ B1004016	1	Ball, 5/32" Dia.	42	*★ P20037	1	Gasket
35	❖ CCA513028-5A	1	Screw, M5 x 8mm Flat Pt.	43	* (See Fig. 7)	1	Release Valve Subass'y
36	* DC10140110	1	Spring, Compression	44	† F100097-52	1	Elbow
37	* DC7309013	1	Ball Guide	65	❖ DD3417059	2	Pin, 6mm x 45mm Long

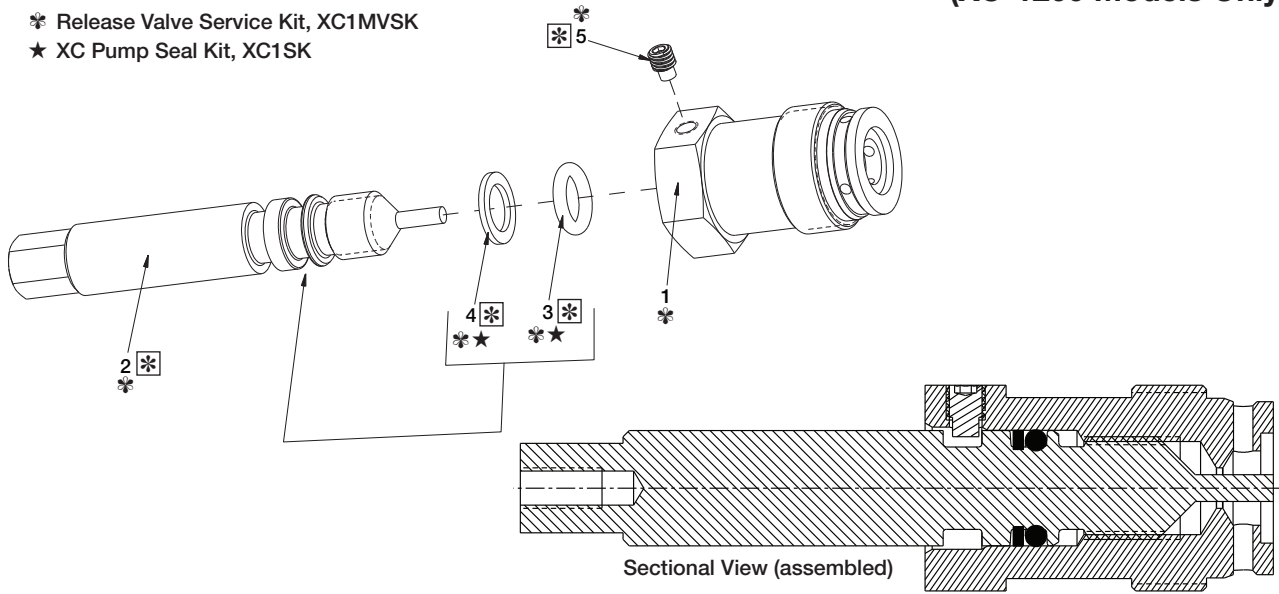
**IMPORTANT:** Shaded items are available only in kits (not sold separately).



**Fig. 7, Release Valve Subassembly  
(XC-1200 Models Only)**

Item included in:

- \* Release Valve Service Kit, XC1MVSK
- ★ XC Pump Seal Kit, XC1SK



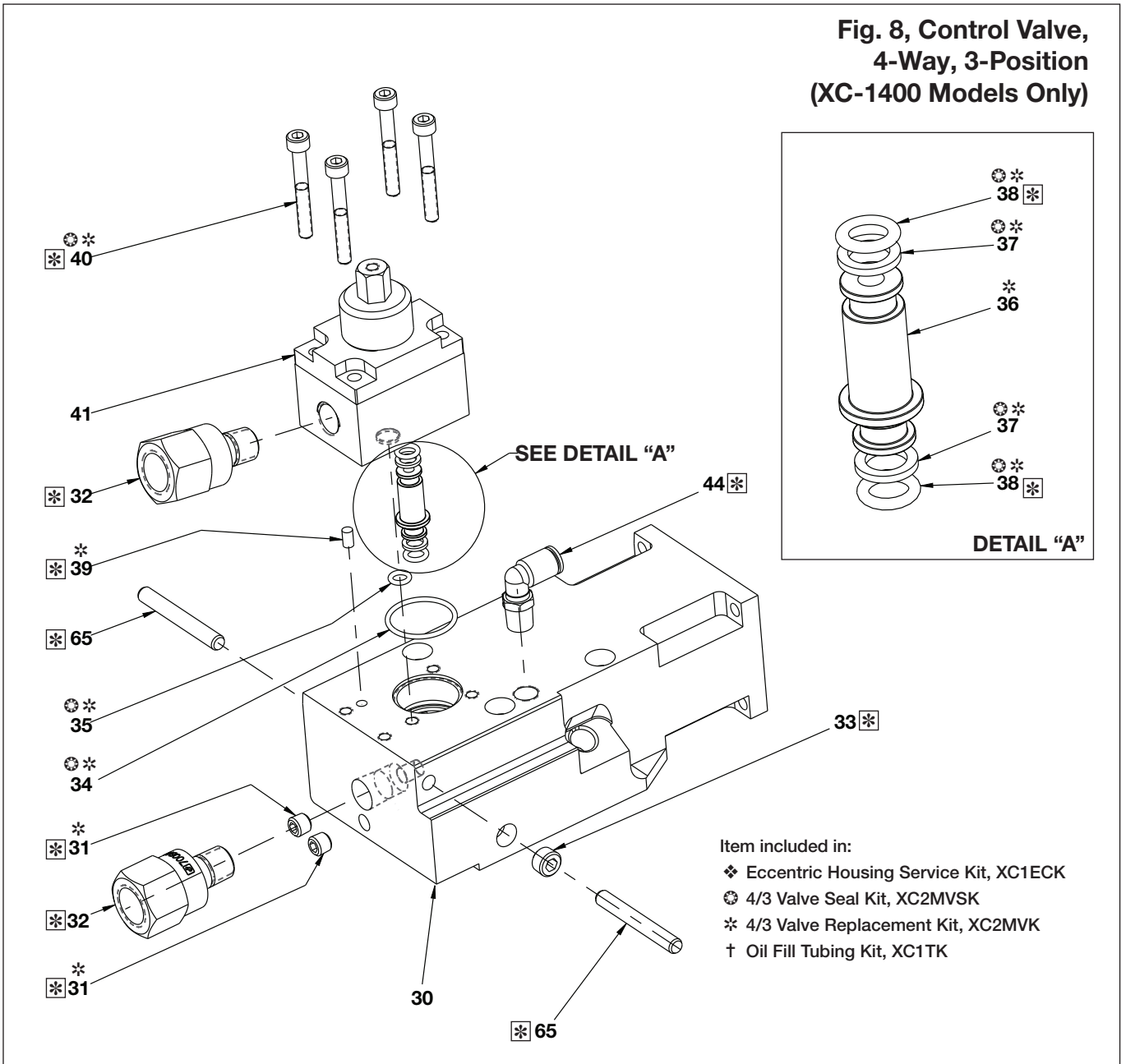
**Repair Parts List, Fig. 7**

**L4006**

Item	Part Number	Qty.	Description	Item	Part Number	Qty.	Description
1	* DD2988013	1	Body, Release Valve	4	*★ B1110564	1	Back-Up, Teflon
2	* DD2992010	1	Spindle, Release Valve	5	* DD3400027	1	Set Screw
3	*★ B1110203	1	O-Ring, Viton				

**IMPORTANT:** Shaded items are available only in kits (not sold separately).

**Fig. 8, Control Valve,  
4-Way, 3-Position  
(XC-1400 Models Only)**



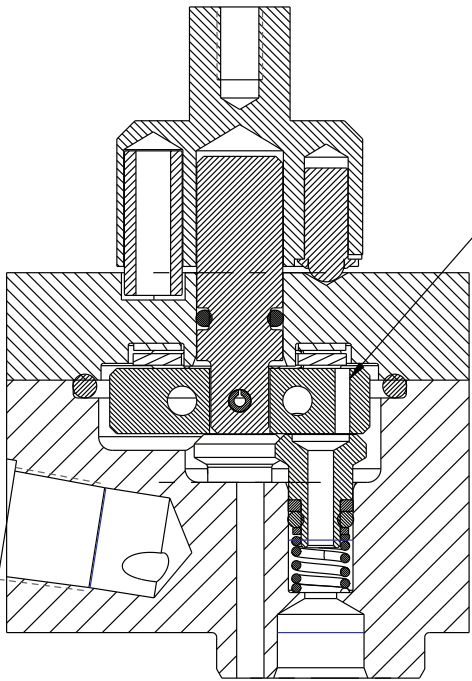
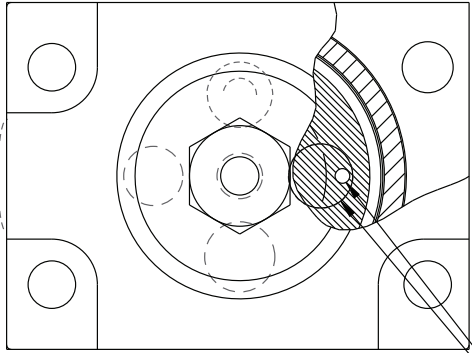
**Repair Parts List, Fig. 8**

**L4006**

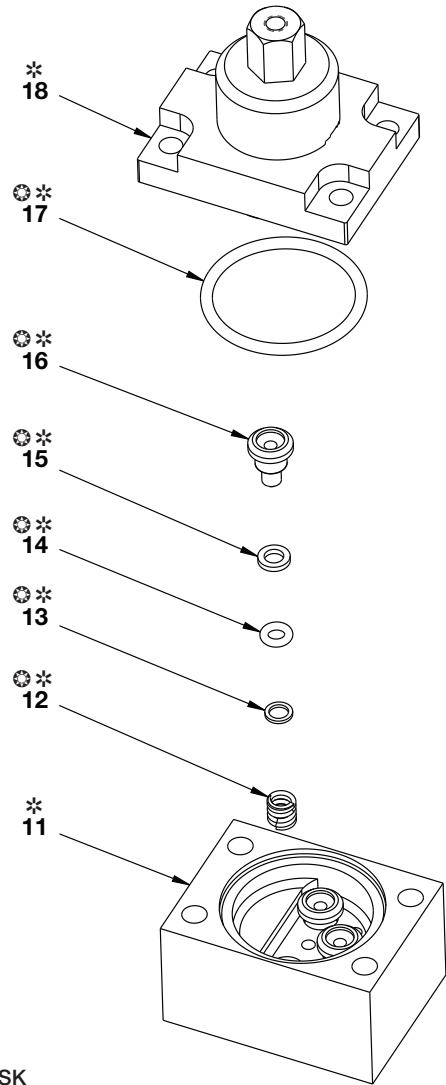
Item	Part Number	Qty.	Description
30	❖ (See Fig. 8)	1	Eccentric and Housing
31	❖ * DC6792245	1	Flush Plug, .062PTF_SAE
32	CF927038	1	Adaptor
33	❖ DC6793245	1	Plug, Flush NPTF .125
34	⊗ * B1227503	1	O-Ring 70 Duro -021
35	⊗ * B1009803	1	O-Ring, .22, x .34 x 06)
36	* DD2996268	2	Transfer Tube, 4/3 Valve XC
37	⊗ * B1010566	2	Teflon Washer
38	⊗ * B1005503	2	O-Ring
39	⊗ * CAA411061-2B	1	Dowel Pin, 4mm Dia. x 8mm Lg.
40	⊗ * CCA529028-1A	1	Screw, SHCS 5 x 40 CLS 12.9 Din 912
41	DD5253900	1	Valve Assembly, 4-Way, 3-Position Manual
44	† F100097.52	1	Elbow
65	❖ DD3417059	1	Pin, 6mm x 45mm Long

**IMPORTANT:** Shaded items are available only in kits (not sold separately).

**Fig. 9, Control Valve,  
4-Way, 3-Position  
(XC-1400 Models Only)**



**ORIENT HOLES  
AS SHOWN**

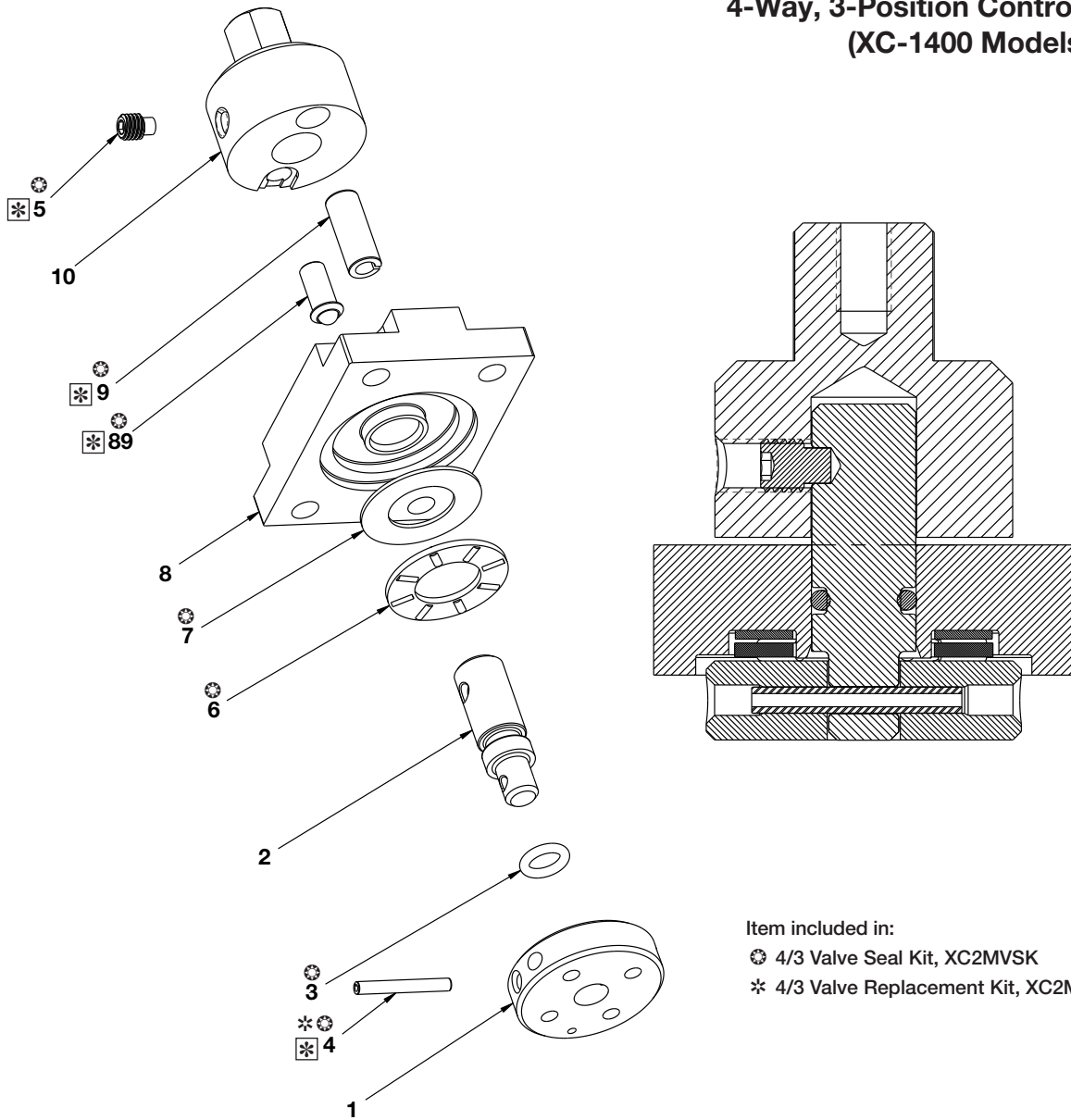


Item included in:  
 ⦿\* 4/3 Valve Seal Kit, XC2MVSK  
 \* 4/3 Valve Replacement Kit, XC2MVK

Repair Parts List, Fig. 9				L4006
Item	Part Number	Qty.	Description	
11	* DD2997840	1	Manifold, 4-Way, 3-Position Valve	
12	⦿* DD4446110	3	Spring, .25" OD, .172" ID	
13	⦿* DD4464108	3	Shim, .171 ID, .241 OD	
14	⦿* B1002503	3	O-Ring	
15	⦿* DA7285566	3	Back-Up Washer	
16	⦿* DA11071041	3	Metal Seal, Poppet	
17	⦿* B1259503	1	O-Ring	
18	* DD5252900	1	Cover Assembly, Valve	

**IMPORTANT: Shaded items are available only in kits (not sold separately).**

**Fig. 10, Valve Cover Assembly,  
4-Way, 3-Position Control Valve  
(XC-1400 Models Only)**



Item included in:

- ⊗ 4/3 Valve Seal Kit, XC2MVSK
- \* ⊗ 4/3 Valve Replacement Kit, XC2MVK

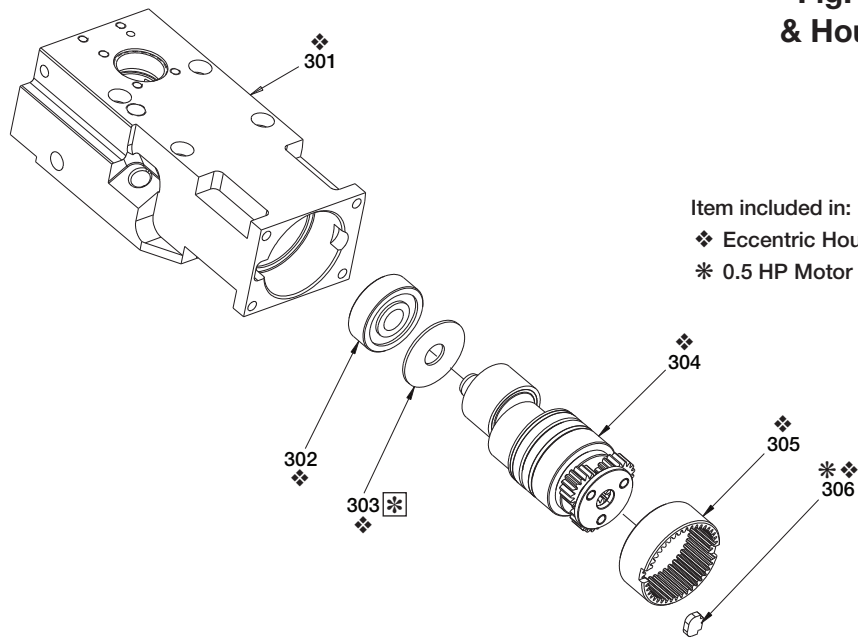
**Repair Parts List, Fig. 10**

**L4006**

Item	Part Number	Qty.	Description
01	DA7289900	1	Assembly, Plug and Disc
02	DD4470104	1	Shaft, Valve
03	⊗ B1005503	1	O-Ring
04	* ⊗ B1040057	1	Spring Pin
05	⊗ DD3400027	1	Set Screw, 10-32 x .25 Long Pt.
06	⊗ CB183155	1	Needle Bearing
07	⊗ CB184155	1	Thrust Race
08	DD4443098	1	Cover, Valve
09	B1126057	1	Roll Pin
10	DD2999489	1	Collar
89	⊗ DD3421013	1	Detent, Safety Lock XB

**IMPORTANT: Shaded items are available only in kits (not sold separately).**

**Fig. 11, Eccentric Shaft & Housing Subassembly**



Item included in:

- ❖ Eccentric Housing Service Kit, XC1ECK
- \* 0.5 HP Motor Service Kit, XC1EMK

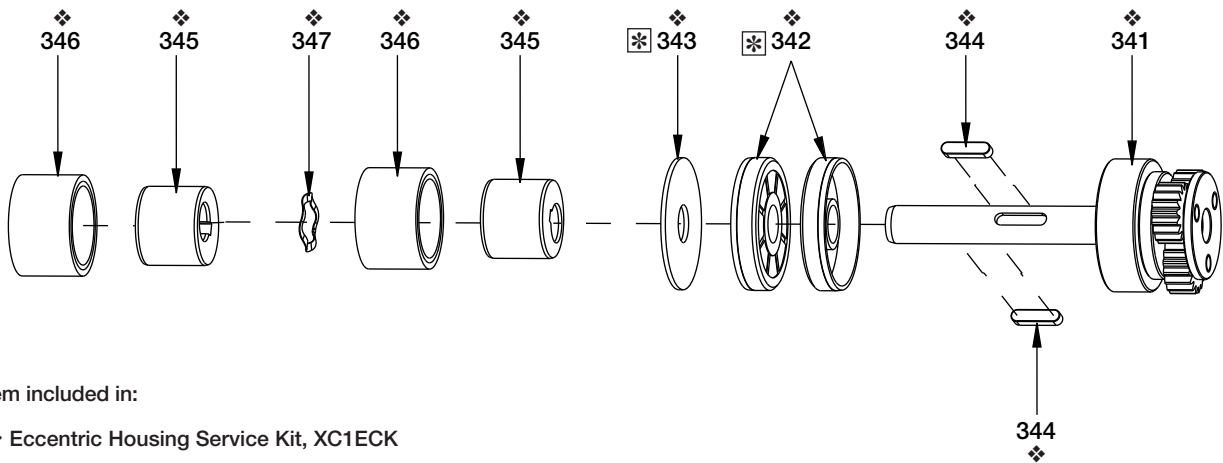
**Repair Parts List, Fig. 11**

**L4006**

Item	Part Number	Qty.	Description	Item	Part Number	Qty.	Description
301	❖ DD2989001	1	Housing, Eccentric	304	❖ (See Fig. 9)	1	Assy, Eccentric Shaft
302	❖ DC7096155	1	Bearing	305	❖ DC7089228	1	Inner Gear
303	❖ DC7464108	1	Bushing 12 x 37 x 1.5	306	*❖ DC7452251	1	Key, Gear Ring

**IMPORTANT:** Shaded items are available only in kits (not sold separately).

**Fig. 12, Eccentric Shaft Subassembly**



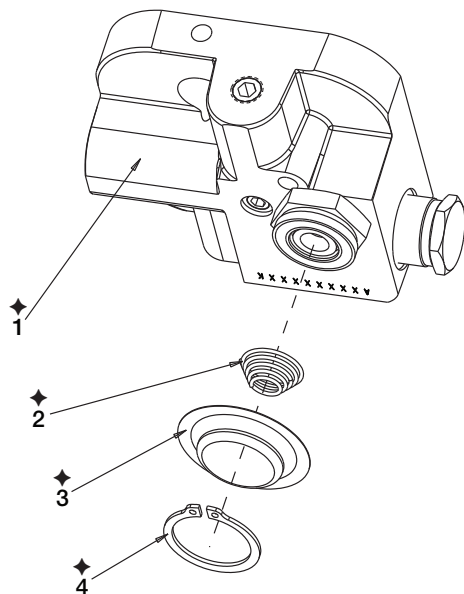
**Repair Parts List, Fig. 12**

**L4006**

Item	Part Number	Qty.	Description	Item	Part Number	Qty.	Description
341	❖ DC7870950	1	S/A, Eccentric Shaft	345	❖ DC7117537	2	Eccentric
342	❖ DC7090476	2	Lip Seal	346	❖ DC7755950	2	Subassembly, Cam
343	❖ DC7186108	1	Washer, Thrust	347	❖ DC7750410	1	Spring, Wave
344	❖ DC7191251	2	Key				

**IMPORTANT: Shaded items are available only in kits (not sold separately).**

**Fig. 13, Pump Assembly**



Item included in:  
 ◆ XVARI Pump Element Kit, XA1PEK

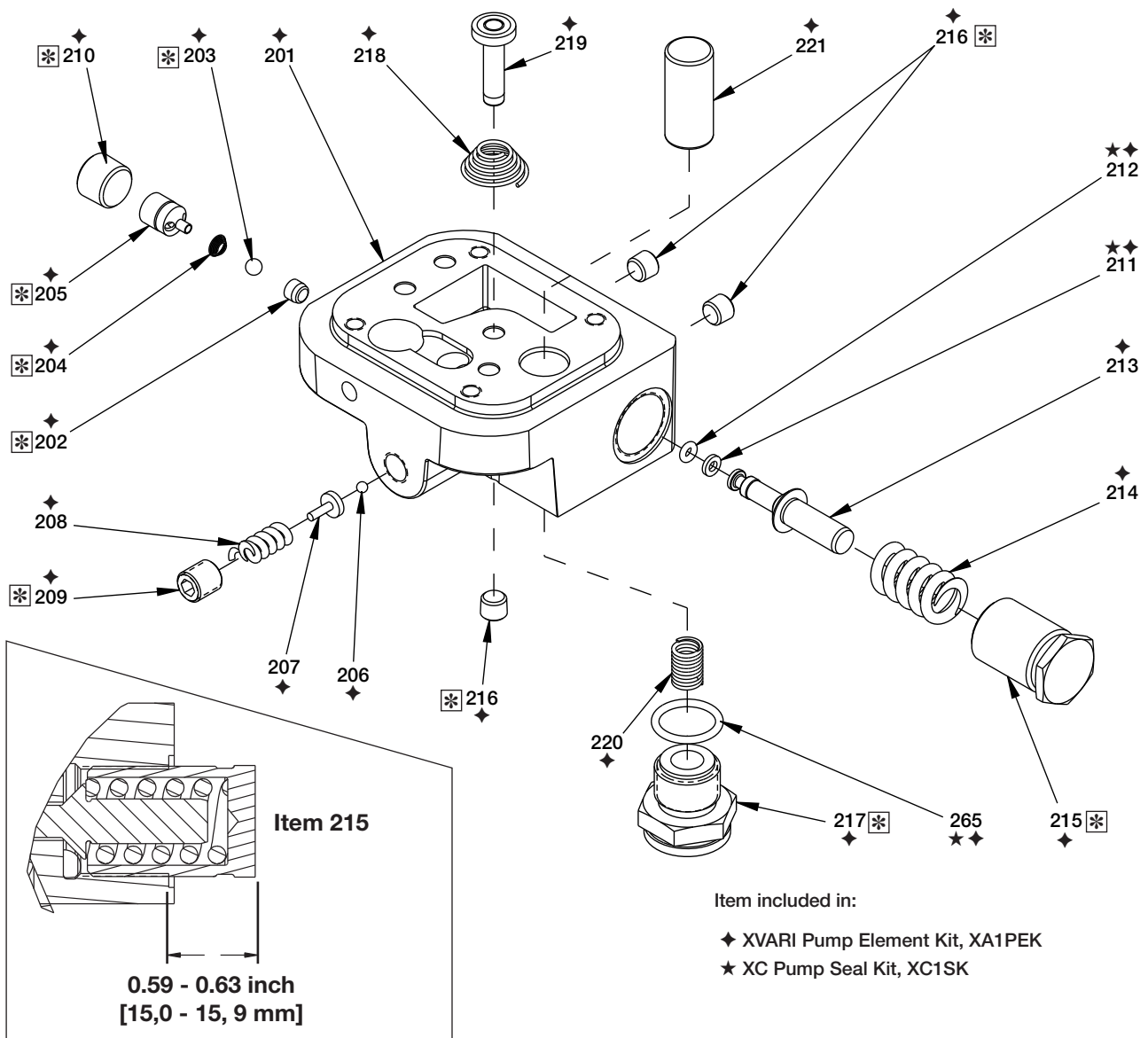
**Repair Parts List, Fig. 13**

**L4006**

Item	Part Number	Qty.	Description
1	◆ DC7206950	1	Assy, Pump Element (See Fig. 11)
2	◆ BSS5509D	1	Spring
3	◆ DC7152018	1	Screen
4	◆ CCA1025044-1A	1	Ring, Retaining

**IMPORTANT: Shaded items are available only in kits (not sold separately).**

Fig. 14, Pump Element



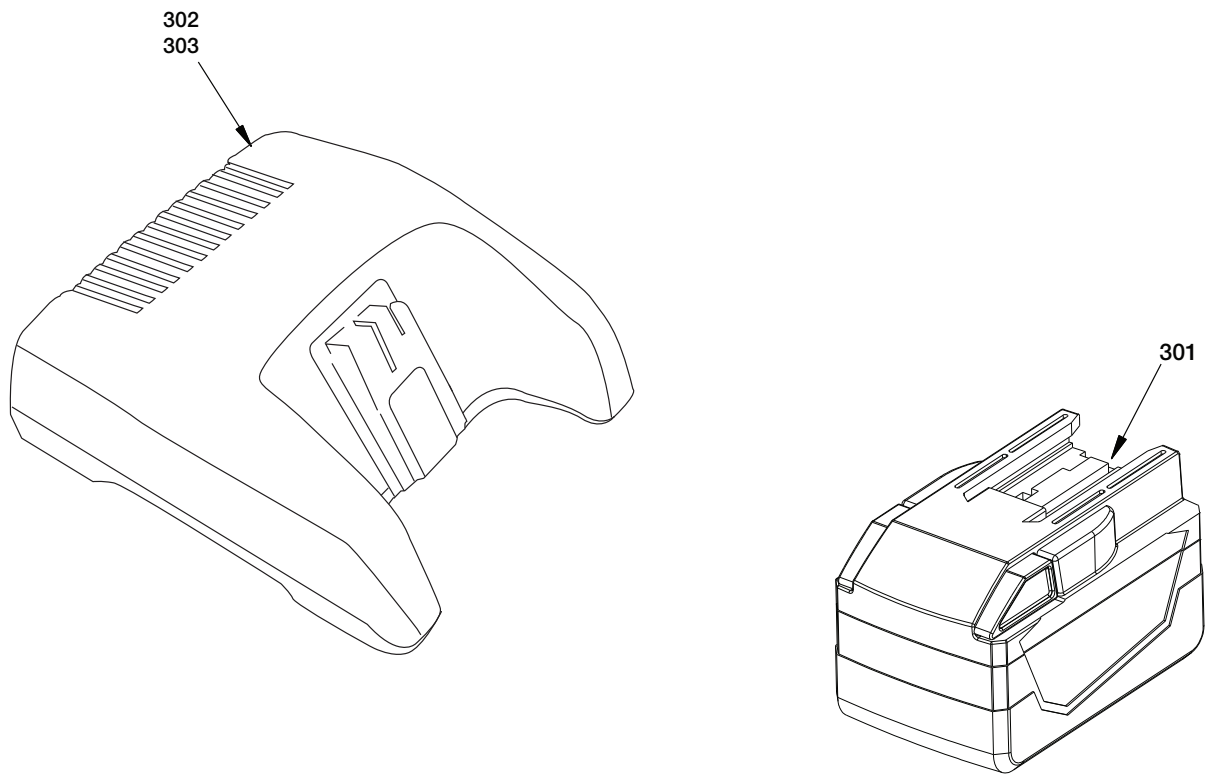
Repair Parts List, Fig. 14

L4006

Item	Part Number	Qty.	Description	Item	Part Number	Qty.	Description
201	◆ DC7201190	1	Body, Pump	212	★◆ B1006803	1	O-Ring, 0.25" O.D.
202	◆ BSS5358D	1	Ball Seat, Inlet	213	◆ DC9292051	1	Piston, Bypass
203	◆ B1005016	1	Ball, 3/16" Dia.	214	◆ DC394110	1	Spring, Bypass
204	◆ BSS5809D	1	Spring	215	◆ DC9208020	1	End Cap, Bypass
205	◆ DC7904900	1	Assy, Outlet Check	216	◆ A1006245	3	Plug, Flush 1/16"
206	◆ B1003016	1	Ball, 1/8" Dia	217	◆ DC7453950	1	Assembly, Inlet Check
207	◆ A8038570	1	Ball Cap	218	◆ BSS5509D	1	Spring, Conical
208	◆ A8126110	1	Spring	219	◆ DC9244920	1	Piston, 6 mm Dia
209	◆ DC1185048	1	Soc. Hd. Set Scw., Hollow	220	◆ DC7026110	1	Spring, Large Piston
210	◆ DC6794245	1	Plug, NPTF 1/4"	221	◆ DC7027051	1	Piston, 14 mm Dia
211	★◆ B1006564	1	Washer, B/U	265	★◆ B1908503	1	O-Ring

IMPORTANT: Shaded items are available only in kits (not sold separately).

**Fig. 15, Battery & Charger**

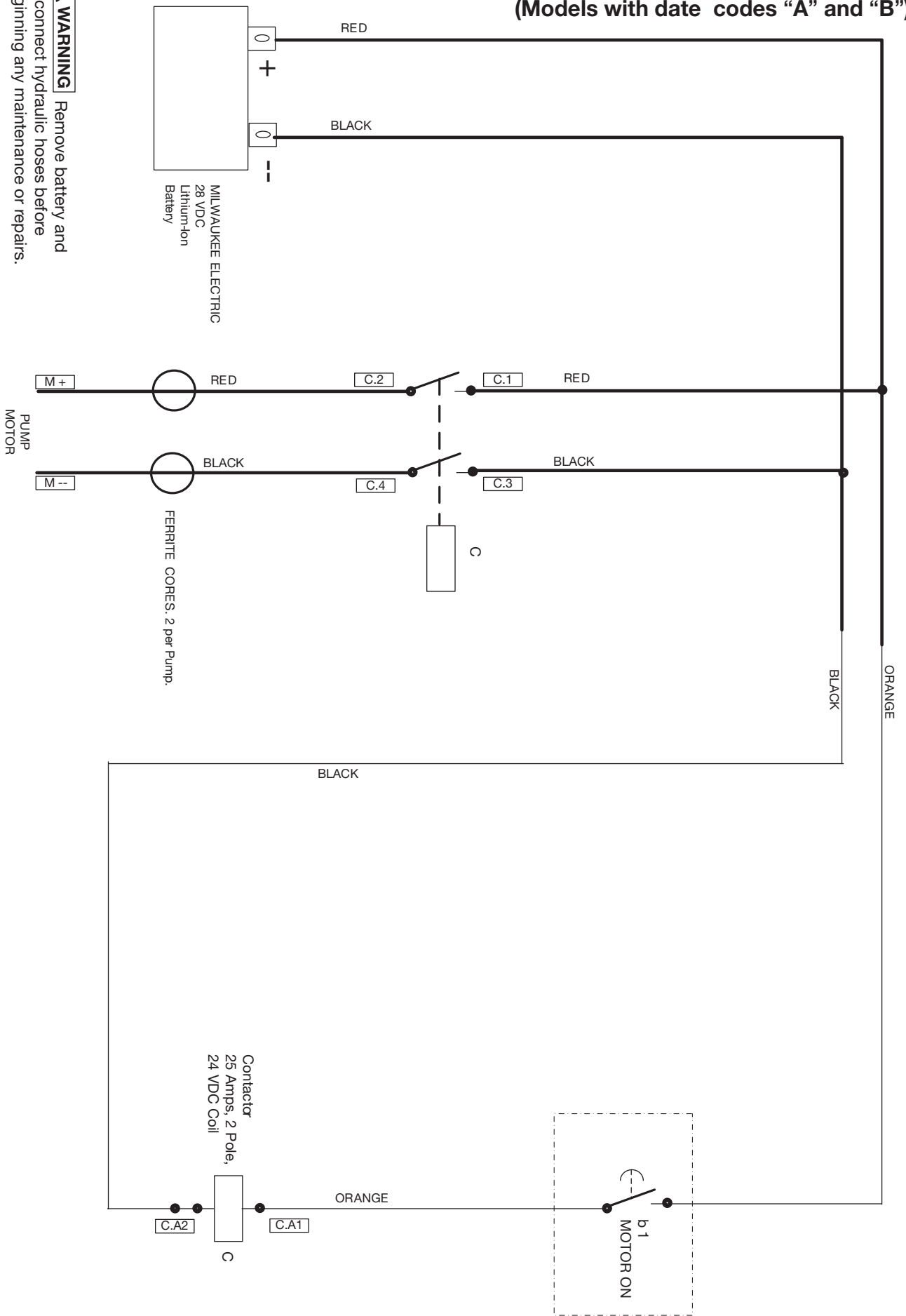


Repair Parts List, Fig. 15				L4006
Item	Part Number	Qty.	Description	
301	XC28V	1	Battery, 28 Volt Li-Ion	
302	XC115VC	1	Battery Charger, 115 VAC input	
303	XC230VC	1	Battery Charger, 230 VAC input	
<p><b>Note:</b> "M28™" and the Milwaukee Electric Tool logo are trademarks and intellectual property of Milwaukee Electric Tool Corporation. Exact appearance of battery and charger may vary.</p>				

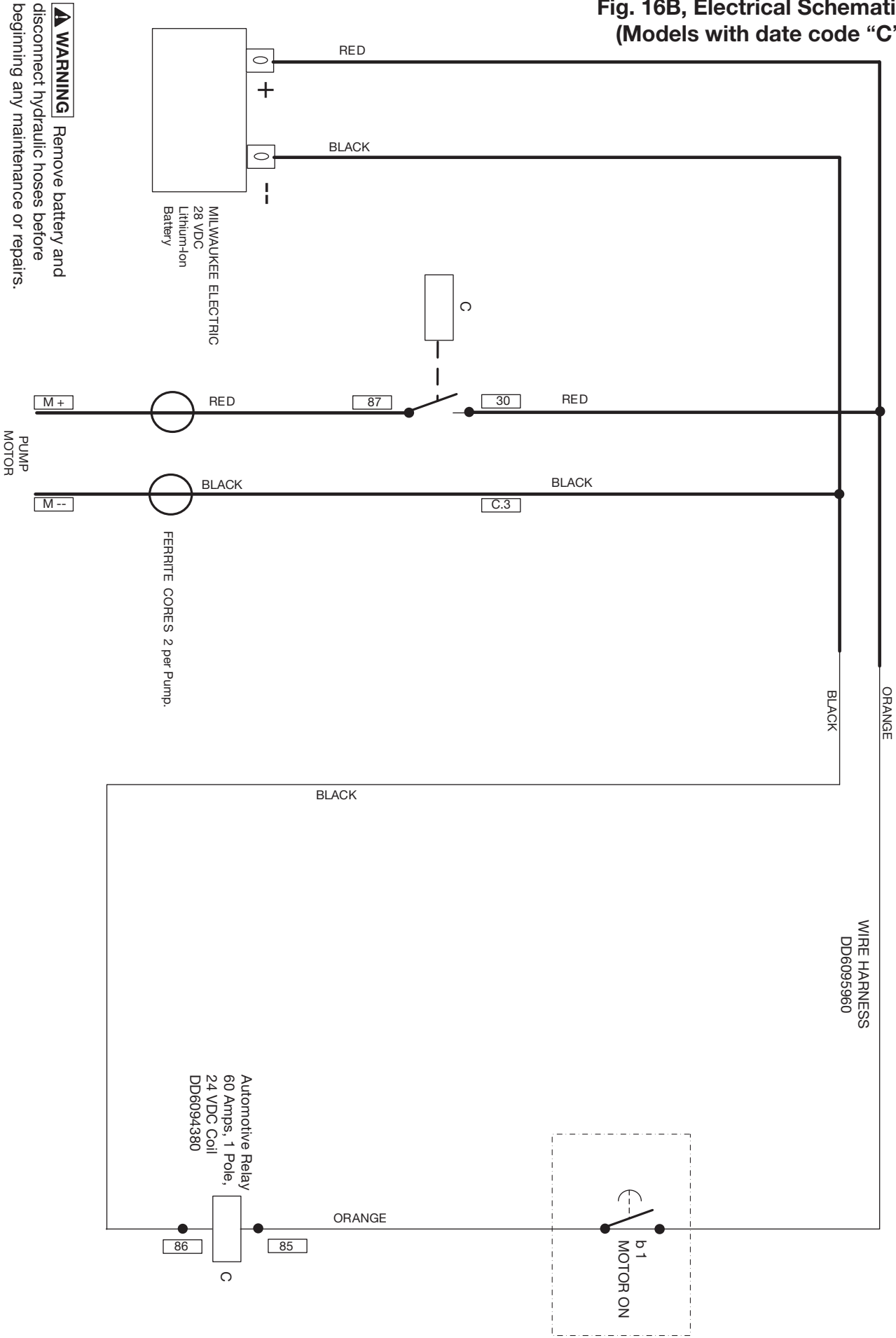


**Fig. 16A, Electrical Schematic  
(Models with date codes "A" and "B")**

**⚠ WARNING** Remove battery and disconnect hydraulic hoses before beginning any maintenance or repairs.



**Fig. 16B, Electrical Schematic  
(Models with date code "C")**





* Service Information		L4006
Fig.	Item	Torque / notes
1	106	4,5 - 5,7 Nm [40 - 50 In - Lbs.]
1	107	Apply self adhesive label. Locate as shown.
1	108	Apply self adhesive label. Locate as shown.
1	109	Apply self adhesive label. Locate as shown.
1	110	Apply self adhesive label. Locate as shown.
1	111	Apply self adhesive label. Locate as shown.
1	115	13,6 - 16,3 Nm [10 - 12 Ft - Lbs]
1	115	When loosening plug (Fig. 1, item 115), use a second wrench to prevent adapter fitting (Fig. 6, item 32) from turning.
2	84	0,9 - 1,1 Nm [8 - 10 In - Lbs]
2	97	No gap between LH and RH shroud halves when assembled.
2	99	2 - 3 Nm [18 - 26 In - Lbs]
2	100	Be sure that item 100 is properly oriented for your pump model. See diagram at bottom of Fig. 2.
2	101	Before installing handle, rotate valve clockwise until it stops.
2	104	Apply Loctite 243.
2	104	2 - 3 Nm [18 - 26 In - Lbs]
3A	76, 77, 78 & 79 and Detail A	Assemble washer and spring below tab in housing.
3A	80	No gap between LH and RH shroud halves when assembled.
3A	84	0,9 - 1,1 Nm [8 - 10 In - Lbs]
3A	85	Orient as shown.
3A	87	Apply Loctite 2760.
3A	87	Install switch mounting nut finger tight on shroud rib, then remove and screw nut on 1/2 turn. Reinstall.
3A	130	Secure cables with wire ties.
3B	‡	Old style relay, bracket and wiring harness (parts marked with ‡) are no longer available. Order harness and relay kit, DD6094380K if replacement is necessary. Replace both wiring harness and relay as a set. Old relay mounting plate is no longer needed and can be discarded. Refer to Figure 3A for new parts arrangement.
4	23	Torque to 4,0 - 5,6 Nm [36 - 50 In - Lbs]
4	70	Apply grease as required when assembling tubes to fitting.
4	71	Push to connect.
4	73	Squeeze until tight.
4	74	Apply grease as required when assembling tube to fitting.
4	75	Squeeze until tight.
5	50, 51	Apply grease to ring gear teeth before installing motor.
5	51	Orient with tab UP.
5	51A	Ferrite cores (item 51A) are included with motor (item 50).
5	104	Apply Loctite 243.
5	104	5,3 - 7,6 Nm [45 - 60 In - Lbs]
5	56	Apply Loctite 2760.
5	56	17,0 - 20,5 Nm [12 - 15 Ft - Lbs]
5	58 - 63	Install last - after pump, bladder and motor.
5	60	Plug includes M4 tapped hole. Remove using M4 screw.
5	64	Install on eccentric housing.

(Continued on next page.)



* Service Information (Continued)		L4006
Fig.	Item	Torque / notes
6	31	Apply Teflon tape to threads.
6	31	13,5 - 16,3 Nm [10 - 12 Ft - Lbs]
6	32	Apply Teflon tape to threads.
6	32	43 - 53 Nm [32 - 39 Ft - Lbs]
6	33	Apply Teflon tape to threads.
6	33	22,0 - 25,0 Nm [16 - 19 Ft - Lbs]
6	35	Apply Loctite 243.
6	35	4,1 - 6,8 Nm [36 - 60 In - Lbs]
6	37	Apply grease to aid assembly.
6	38, 41	Coin seat before installation.
6	43	Apply Loctite 243.
6	43	122,0 - 128,8 Nm [90 - 95 Ft - Lbs] (valve body)
6	44	Apply Teflon tape to threads.
6	44	4,1 - 6,8 Nm [30 - 60 In - Lbs]
6	65	Press fit.
7	2	Turn counter-clockwise to assemble. Turn-in until groove is seen in body through hole.
7	3, 4	Apply grease to O-Ring and back-up after assembly to spindle, before assembly to body.
7	5	Apply Loctite 243.
7	5	2,4 - 3,0 Nm [21 - 26 In - Lbs]
8	31	13,5 - 16,3 Nm [10 - 12 Ft - Lbs]
8	32	Apply Teflon tape to threads.
8	32	43 - 53 Nm [32 - 39 Ft - Lbs]
8	33	22,0 - 25,0 Nm [16 - 19 Ft - Lbs]
8	38	Lubricate seals before assembling them into items 41 and 30.
8	39	Press fit.
8	40	Apply Loctite 243.
8	40	4,6 - 5,4 Nm [55 - 65 In - Lbs]
8	44	Torque to 4,0 - 7,6 Nm [36 - 60 In - Lbs]
8	65	Press fit.
10	1	Orient as shown before assembly.
10	4	Press fit into item 1 when aligned with item 2.
10	5	Apply Loctite 243.
10	5	2,4 - 3,0 Nm [21 - 26 In - Lbs]
10	9	Press fit into item 10.
10	89	Press fit into item 10.

(Continued on next page.)

* Service Information (Continued)		L4006
Fig.	Item	Torque / notes
12	303	Position gray coated side of bushing (item #303) toward eccentric (item #304).
12	342, 343	Position gray coated side of thrust washer (item 343) toward eccentric (item 345).
14	202, 203 204, 205	Outlet check valve components are permanently installed in valve body. These components cannot be removed.
14	209	Set safety relief valve pressure to 711 - 737 Bar [10300 - 10700 Psi].
14	210	Apply Teflon tape to threads.
14	210	60 - 71 Nm [44.2 - 52.3 Ft - Lbs]
14	215	Bypass setting end cap dimension: 15,0 - 15,9 mm [0.59 - 0.63 inch] (measured from counterbore to edge of cap)
14	216	Apply Teflon tape to threads.
14	216	13 - 16 Nm [9.8 - 11.8 Ft - Lbs]
14	217	25 - 30 Nm [18.4 - 22.1 Ft - Lbs]





## Enerpac Worldwide Locations

◆ e-mail: [info@enerpac.com](mailto:info@enerpac.com)

◆ internet: [www.enerpac.com](http://www.enerpac.com)

### Australia and New Zealand

Actuant Australia Ltd.  
P.O. Box 6867  
Wetherhill Park, NSW 1851  
Block V Unit 3  
Regents Park Estate  
391 Park Road  
Regents Park NSW 2143  
Australia  
T +61 287 177 200  
F +61 297 438 648

### Brazil

Power Packer do Brasil Ltda.  
Rua Luiz Lawrie Reid, 548  
09930-760 - Diadema (SP) - Brazil  
T +55 11 5687 2211  
Toll Free: 0800 891 5770

### China (Taicang)

Actuant (China) Industries Co. Ltd.  
No.6 Nanjing East Road,  
Taicang Economic Dep Zone  
Jiangsu, China  
T +86 0512 5328 7500  
F +86 0512 5335 9690  
Toll Free: +86 400 885 0369

### France, Switzerland, North Africa and French speaking African countries

ENERPAC  
Une division d'Actuant France S.A.S  
Zone Orlytech Bâtiment 516  
1 allée du commandant Mouchotte  
CS 40351  
91550 Paray-Vieille-Poste  
France  
T +33 1 60 13 68 68  
F +33 1 69 20 37 50

### Germany and Austria

Actuant GmbH  
P.O. Box 300113  
D-40401 Düsseldorf  
Willstätterstrasse 13  
D-40549 Düsseldorf, Germany  
T +49 211 471 490  
F +49 211 471 49 28

### India

Actuant India Private Limited  
No. 10, Bellary Road, Sadashivanagar,  
Bangalore, Karnataka 560 080  
India  
T +91 80 3928 9000

### Italy

ENERPAC S.p.A.  
Via Canova 4  
20094 Corsico (Milano)  
T +39 02 4861 111  
F +39 02 4860 1288

### Japan

Enerpac Co., Ltd.  
Besshocho 85-7  
Kita-ku, Saitama-shi 331-0821, Japan  
T +81 48 662 4911  
F +81 48 662 4955

### Middle East, Egypt and Libya

ENERPAC Middle East FZE  
Plot M00737m 1242nd Street  
Jebel Ali Free Zone North  
P.O. Box 18004, Dubai  
United Arab Emirates  
T +971 (0)4 8872686  
F +971 (0)4 8872687

### Russia

Rep. office Enerpac  
Russian Federation  
Admirala Makarova Street 8  
125212 Moscow, Russia  
T +7 495 98090 91  
F +7 495 98090 92

### Norway

Sales Office Norway  
Unit 524, Nydalsveien 28, 0484 Oslo  
P.O. Box 4814, Nydalen 0422 Oslo  
Norway  
T +47 91 578 300

### Southeast Asia, Hong Kong and Taiwan

Actuant Asia Pte Ltd.  
83 Joo Koon Circle  
Singapore 629109  
T +65 68 63 0611  
F +65 64 84 5669  
Toll Free: +1800 363 7722

### South Korea

Actuant Korea Ltd.  
3Ba 717, Shihwa Industrial Complex  
Jungwong-Dong, Shihung-Shi,  
Kyunggi-Do  
Republic of Korea 429-450  
T +82 31 434 4506  
F +82 31 434 4507

### Spain and Portugal

ENERPAC SPAIN, S.L.  
Avda. Valdelaparra N° 27 3ª - L8  
28108 Alcobendas (Madrid), Spain  
T +34 91 884 86 06  
F +34 91 884 86 11

### Sweden, Denmark

**Finland and Iceland**  
Enerpac Scandinavia AB  
Kopparlundsvägen 14,  
721 30 Västerås  
Sweden  
T +46 (0) 771 41 50 00

### The Netherlands, Belgium, Luxembourg, Central and Eastern Europe, Baltic States, Greece, Turkey and CIS countries

ENERPAC B.V.  
Galvanistraat 115, 6716 AE Ede  
P.O. Box 8097, 6710 AB Ede  
The Netherlands  
T +31 318 535 911  
F +31 318 535 848

### Enerpac Heavy Lifting Technology B.V.

Spinelstraat 15, 7554 TS Hengelo  
P.O. Box 421, 7550 AK Hengelo  
The Netherlands  
T +31 74 242 20 45  
F +31 74 243 03 38

### South Africa and other English speaking African countries

Enerpac Africa Pty Ltd.  
No. 5 Bauhinia Avenue  
Cambridge Office Park  
Block E  
Highveld Techno Park  
Centurion 0157  
Republic of South Africa  
T: +27 12 940 0656

### United Kingdom and Ireland

ENERPAC UK Ltd.  
5 Coopies Field  
Morpeth, Northumberland  
NE61 6JR, England  
T +44 1670 5010 00

### USA, Latin America and Caribbean

ENERPAC World Headquarters  
P.O. Box 3241  
Milwaukee WI 53201-3241 USA  
N86 W12500 Westbrook Crossing  
Menomonee Falls, Wisconsin 53051  
T +1 262 293 1600  
F +1 262 293 7036  
User inquiries:  
T +1 800 433 2766  
Distributor inquiries/orders:  
T +1 800 558 0530  
F +1 800 628 0490

All Enerpac products are  
guaranteed against defects  
in workmanship and materials  
for as long as you own them.

For the location of your nearest  
authorized Enerpac Service Center,  
visit us at [www.enerpac.com](http://www.enerpac.com)

040717

# ENERPAC

Visit [www.enerpac.com](http://www.enerpac.com) for the location of the  
Enerpac Authorized Service Center nearest you.