

Contents:

Figure 1 - Pump Side View	2	Figure 9 - Shroud Wiring - Front of Motor	5
Figure 2 - Pump Front View (shroud removed)	2	Figure 10 - Shroud Wiring - Left of Motor	5
Figure 3 - Valve Assembly, VM4	2	Figure 11 - Shroud Wiring - Right of Motor	5
Figure 4 - Pump Bottom View	2	Figure 12 - Top View, Cord and Cables	6
Figure 5 - Pump Front View (assembled)	3	Figure 13 - Pendant Assembly	7
Figure 6 - Adapter Block Details	3	Figure 14 - Electrical Schematic, 115V Models	8
Figure 7 - Pump Top View	4	Figure 15 - Electrical Schematic, 230V Models	8
Figure 8 - Shroud Wiring - Behind Motor	5		

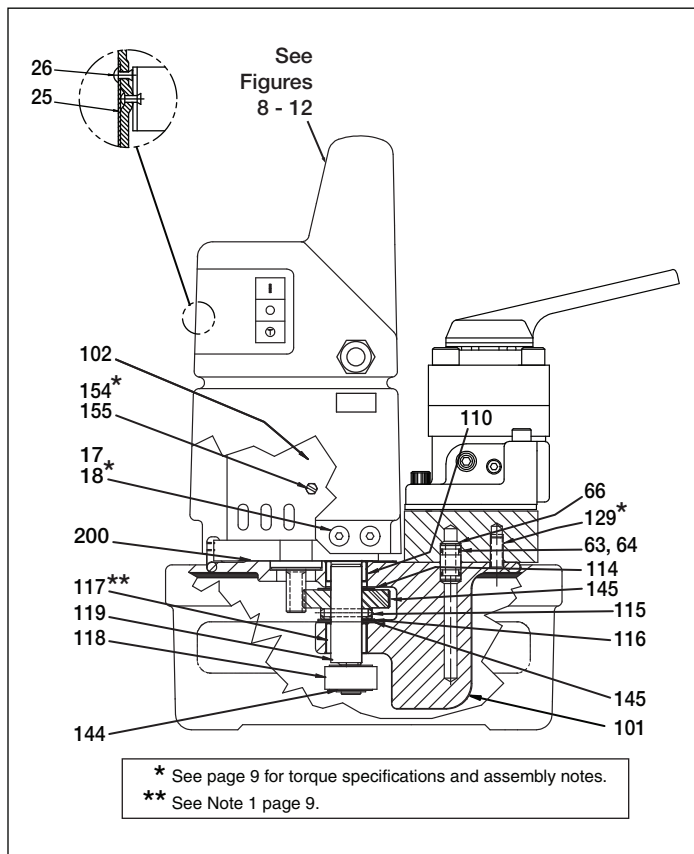

Figure 1, Pump Side View

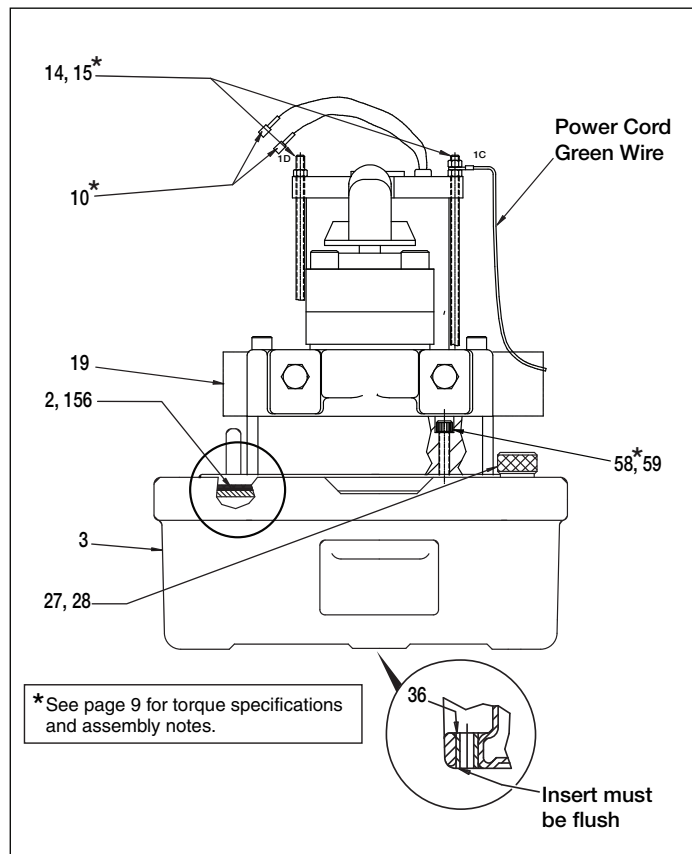

Figure 2, Pump Front View (shroud removed)

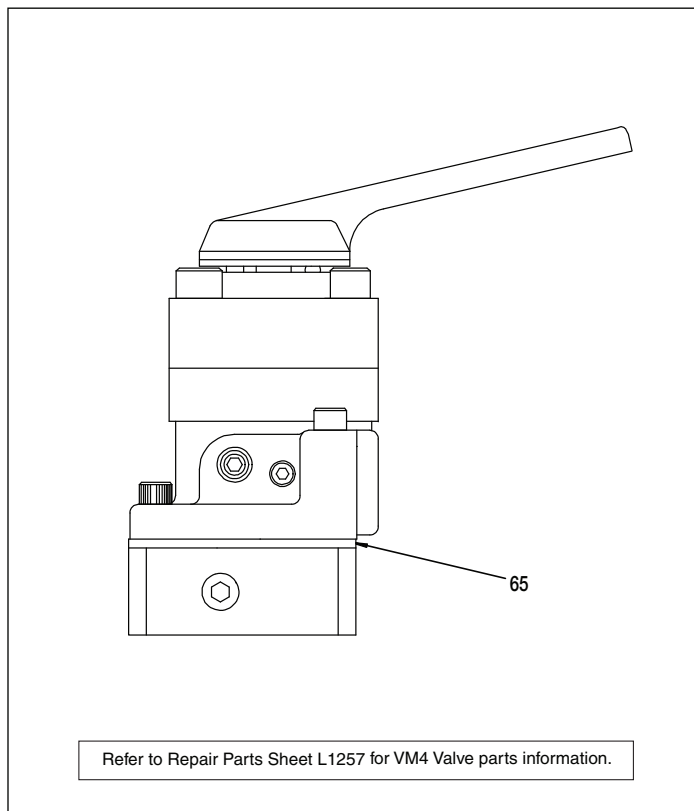

Figure 3, Valve Assembly, VM4

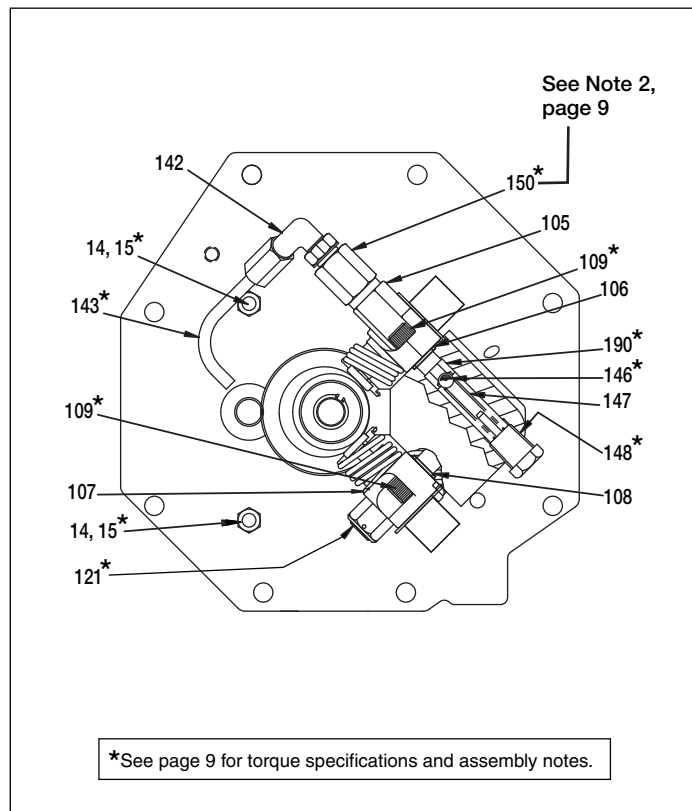

Figure 4, Pump Bottom View

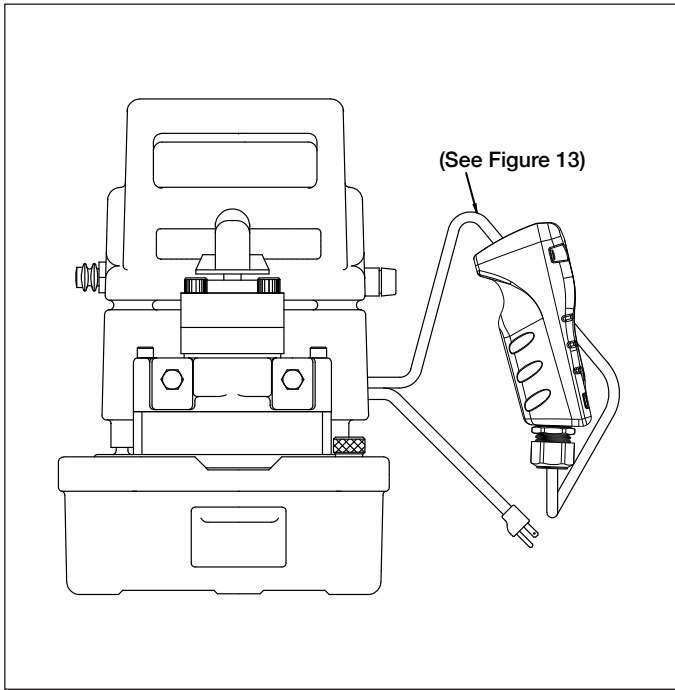

Figure 5, Pump Front View (assembled)

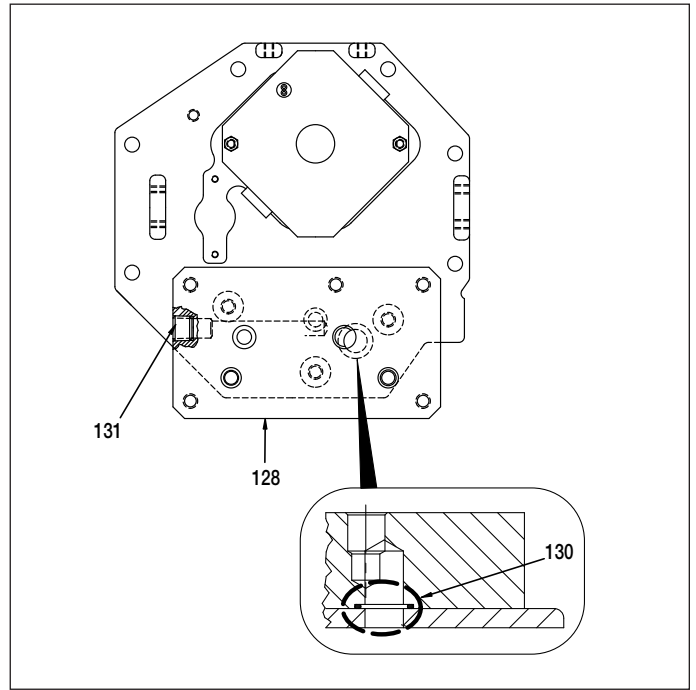

Figure 6, Adaptor Block Details

Repair Parts List for Figures 1 through 6

Item	Part Number	Qty.	Description
2	★DA12088167SR	1	Gasket (Includes item 156)
3	DA1910900SR	1	Reservoir Assembly. 0.5 Gal.
	DA4780900SR	1	Reservoir Assembly. 1.0 Gal.
10	DA3776006	2	Pin
14	DA15066	3	Lock Washer
15	B1018121	3	Hex Nut
17	CW261225	6	Eyelet
18	F866028	6	Machine Screw
19	CW259298	1	Baffle
25	Contact Enerpac	1	Nameplate
26	DC818003	4	Pop Rivet
27	DA608024	1	Vent Plug
28	★B1906503	1	O-Ring
36	DA931225	2	Insert
58	B1019028	2	Screw
59	★S3037	2	Gasket
63	★B1007503	5	O-Ring
64	★B1012564	4	Ring, Back-up
65	★F786167	1	Gasket
66	C162096	1	Connector
101	DA12487840SR	1	Pump Manifold (includes # 121)
102	CW179259	1	115 VAC Motor
	DC1415259	1	230 VAC Motor (50 Hz)
105	DD1449051SR	1	Piston Block Assembly, 14mm
106	★B1007503	1	O-Ring
107	DD1450051SR	1	Piston Block Assembly, 6mm
108	★B1012803	1	O-Ring
109	B1010028X	4	Screw
110	CW252107	1	Bearing

Item	Part Number	Qty.	Description
114	CW301228	1	Driven Gear
115	B1097057	1	Spring Pin
116	CW199107	1	Bearing
117	CW251107	1	Bearing
118	CW302107	1	Bearing
119	CW303104	1	Shaft
121	DA5999900SR	1	Relief Valve (see Figure 4)
128	CW522038	1	Adaptor Block
129	DA3012028	3	Screw
130	★B1206517	1	Square Ring
131	DC6794245	1	Plug
142	DA1011096	1	Elbow
143	DA261268	1	Tube
144	CW467044	1	Retaining Ring
145	DA445107	2	Bearing
146	★B1007016	1	Ball
147	★DA1564110	1	Spring
148	DC433950	1	Plug Assembly
150	DA610900SR	1	Relief Valve Assembly
154	CU876028	3	Screw (10-24)
155	DA3585186	3	Spacer
156	See item 2	1	Gasket
190	DA12352290	1	Ball Seat
200	★DC1947167	1	Gasket

Replacement Brushes for Electric Motor

- - -	DA9655380	1	Brush Set for 115V Models
- - -	DA9656380	1	Brush Set for 230V Models

★ Included in Repair Kit PUJ1400BK

*See page 9 for torque specifications and assembly notes.

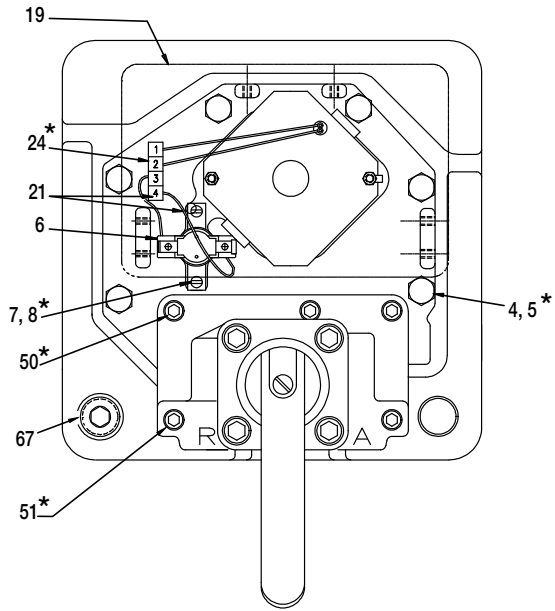

Figure 7, Pump Top View

Repair Parts List for Figure 7

Item	Part Number	Qty.	Description
4	DA6954167	8	Gasket
5	DC2038028	8	Screw
6	E1100004	1	Thermostat (115V)
	DC8401372	1	Thermostat (230V)
7	C701222	2	Washer
8	M642028	2	Screw
19	CW259298	1	Baffle
21	DC7969960	2	Wire Assembly
24	DA11540380	1	Pin Housing
50	B1349028	3	Screw
51	B1357028	2	Screw
67	A1009245	1	Plug

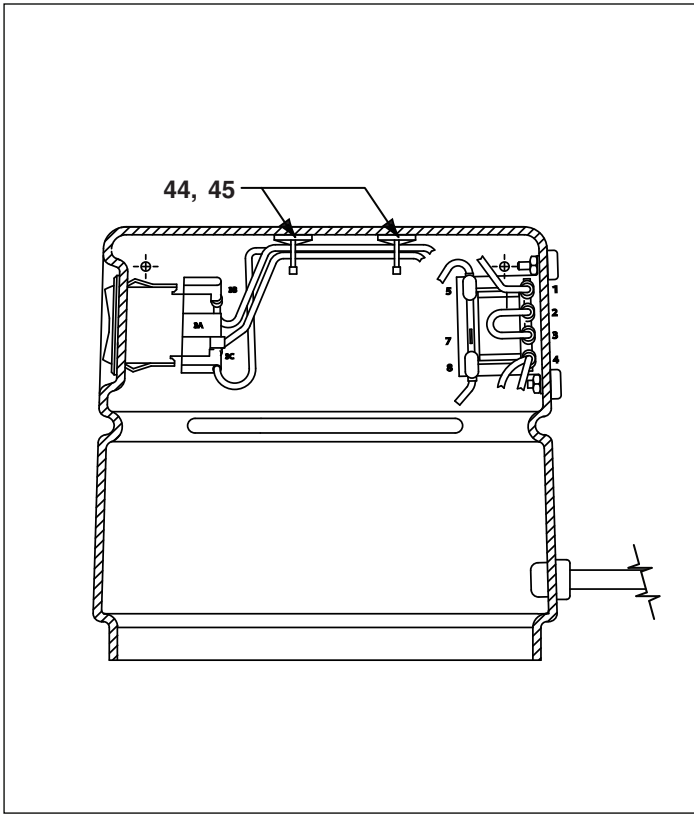

Figure 8, Shroud Wiring - Behind Motor

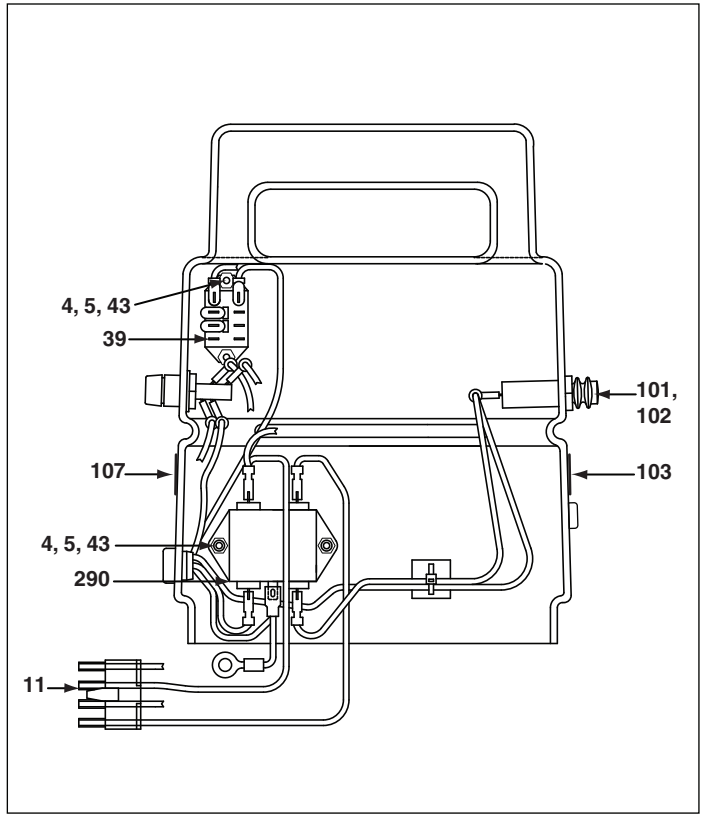

Figure 9, Shroud Wiring - Front of Motor

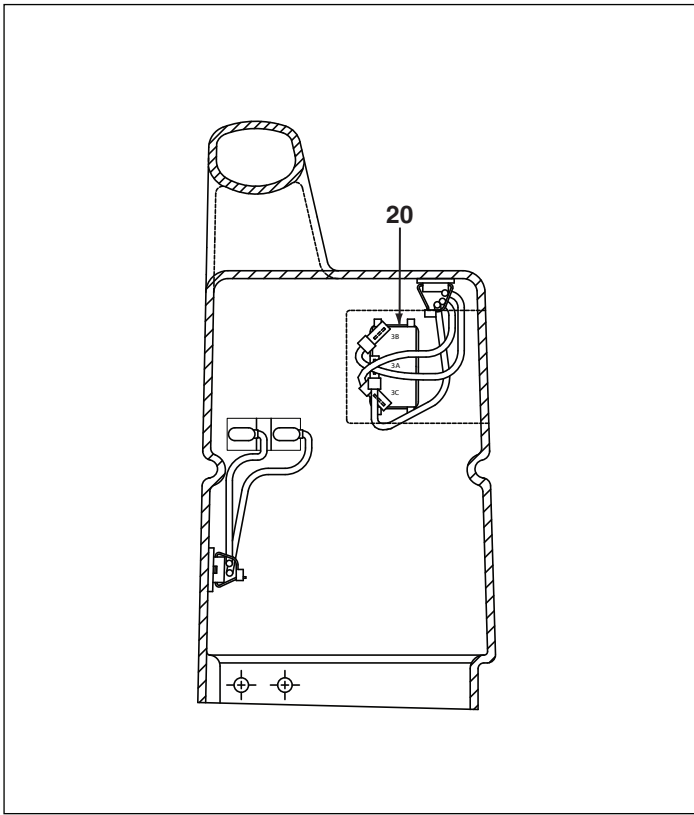

Figure 10, Shroud Wiring - Left of Motor

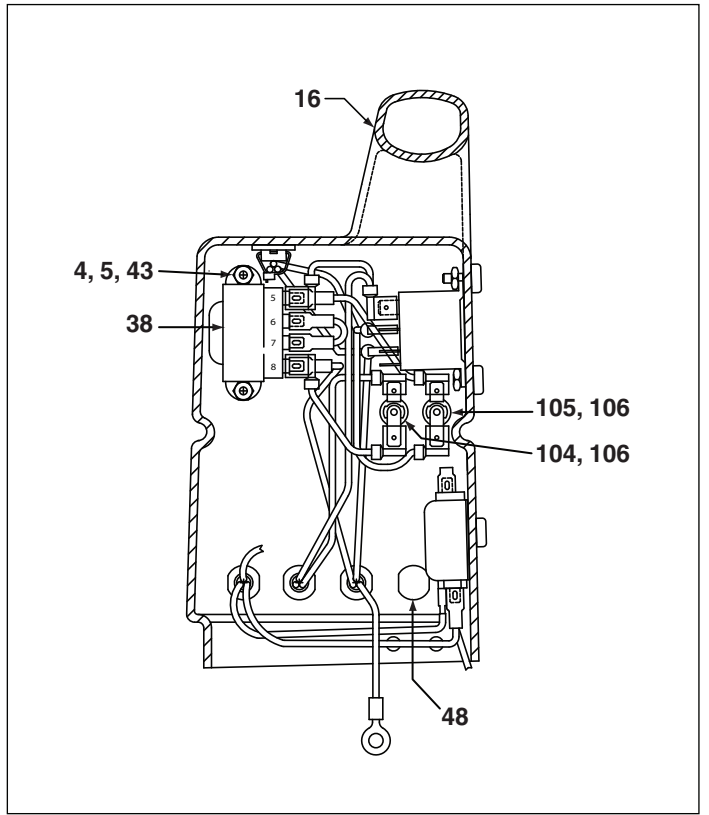

Figure 11, Shroud Wiring - Right of Motor

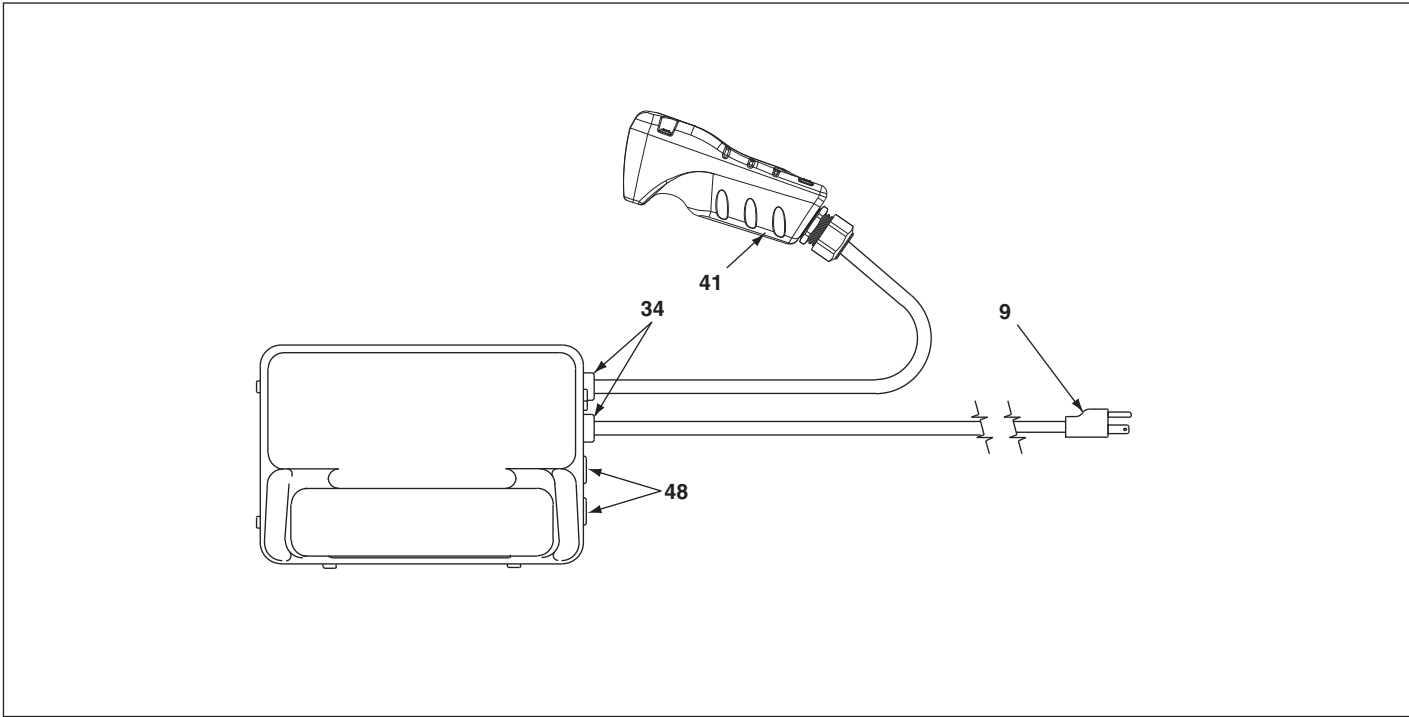

Figure 12, Top View, Cord and Cables

Repair Parts List for Figures 8 through 12

Item	Part Number	Qty.	Description	Item	Part Number	Qty.	Description
4	BC1310728	4	Screw (115V)	43	DA5974098	4	Screw Cover (115V)
	BC1310728	6	Screw (230V)		DA5974098	6	Screw Cover (230V)
5	F75021	4	Lock Nut #6-32 (115V)	44	EHC3901075	3	Tie Down, Self Adhesive
	F75021	6	Lock Nut #6-32 (230V)	45	DA3131217	4	Cable Tie
9	DC7954960SR	1	Power Cord (115V)	48	DA3731009	2	Hole Plug
	DD5840960SR	1	Power Cord (230V)	101	DC8366380	1	Circuit Breaker (115V)
11	DA11539380	1	Receptacle		DC8367380	1	Circuit Breaker (230V)
16	DC10037098	1	Shroud (115V)	102	DC8200380	1	Circuit Breaker Reset Cap
	DC10036098	1	Shroud (230V)	103	DC8237023	1	Circuit Breaker Decal
20	E1500002	1	Switch	104	DC8371378	1	Secondary Fuse, 300mA
34	CR759291	2	Cord Bushing	105	DC8370378	1	Primary Fuse, 62mA (115V)
38	DA5875380	1	Transformer		DC8400378	1	Primary Fuse, 40mA (230V)
39	DD2668380	1	Relay, D1 (115V)	106	DC8372378	2	Fuse Holder
	DC8280980	1	Relay, D1 (230V)	107	DC7891026	1	Fuse Decal
41	(See Fig. 13)	1	Pendant Assy	290	DC8365380	1	EMI Filter (230V only)

Note: For replacement shroud assembly:
 • 115V Models: Order Repair Kit DC7933900SR.
 • 230V Models: Order Repair Kit DC7934900SR.

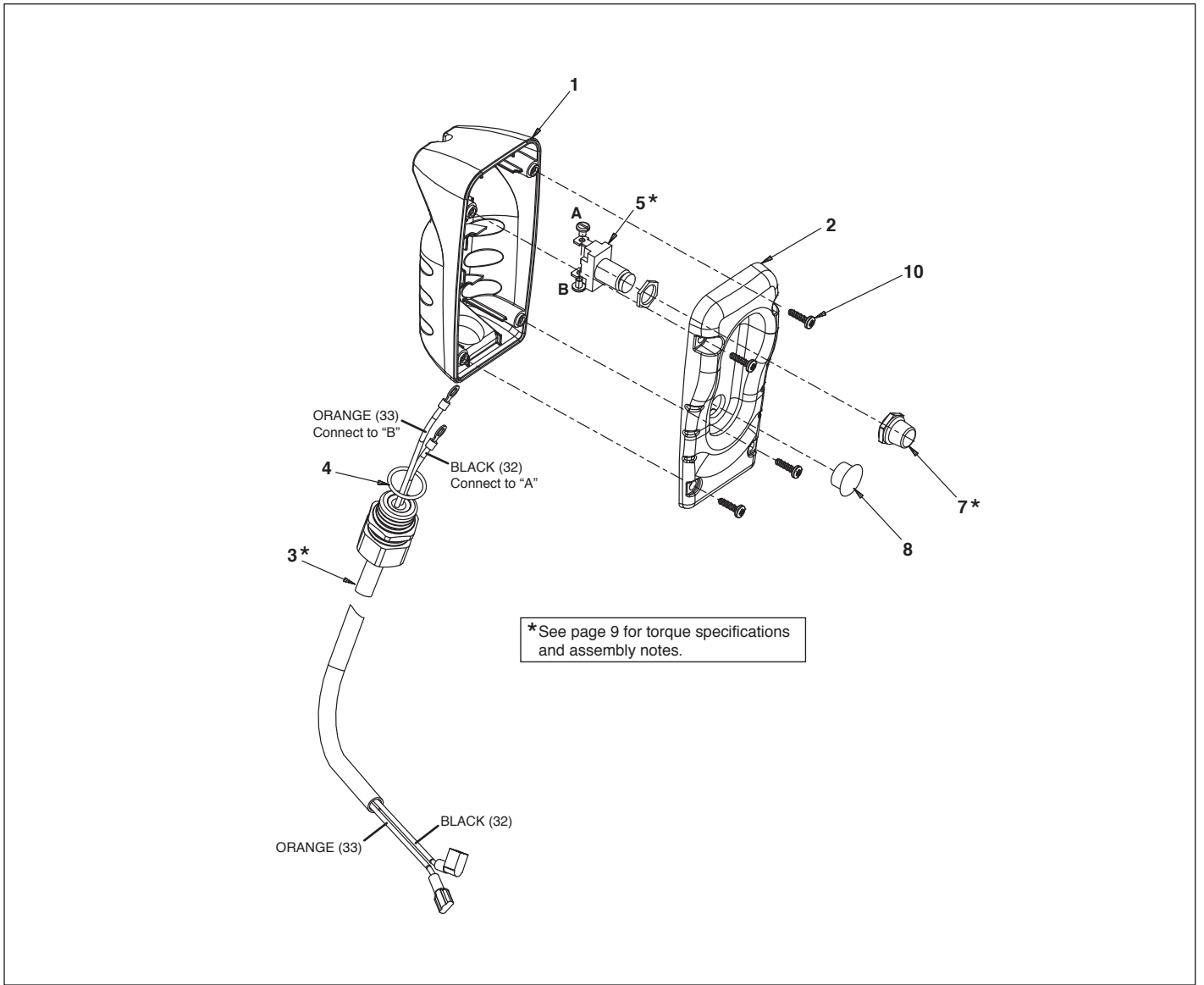

Figure 13, Pendant Assembly

Repair Parts List for Figure 13							
Item	Part Number	Qty.	Description	Item	Part Number	Qty.	Description
1	DC9425424	1	Assembly, Lower Pendant	5	DC8282379	1	Switch, Push Button
2	DC8122424	1	Assembly, Upper Pendant	7	DC8284379	1	Boot, Push Button
3	DD2684960	1	Pendant Cord (115V Models)	8	DC8228009	1	Dome Plug, 1/2"
	DD1053960	1	Pendant Cord (230V Models)	10	DC9428008	4	Screw, Hi-Lo #8 x1/2"
4	B1223503	1	O-Ring				

Complete replacement pendant assembly (includes all items shown in Fig. 12):

- 115V Models: order Repair Kit DD2686900SR.
- 230V Models: order Repair Kit DD1048900SR.

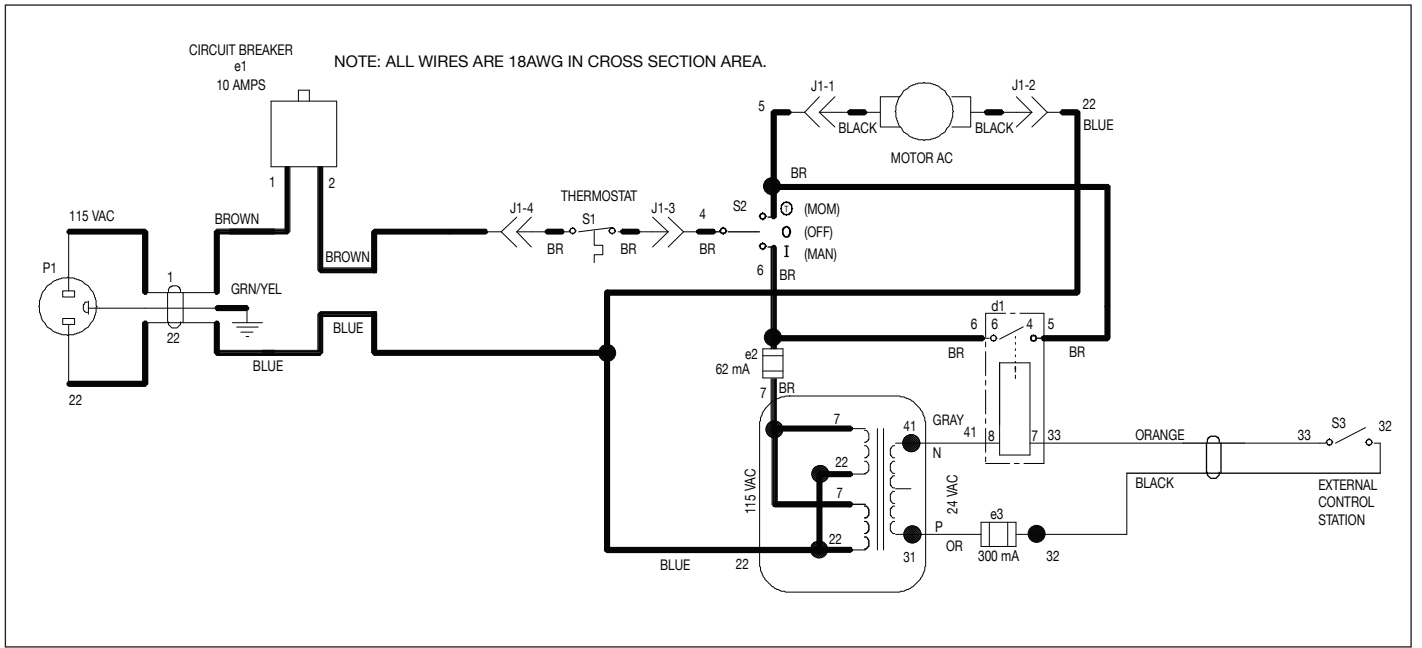

Figure 14, Electrical Schematic, 115V Models

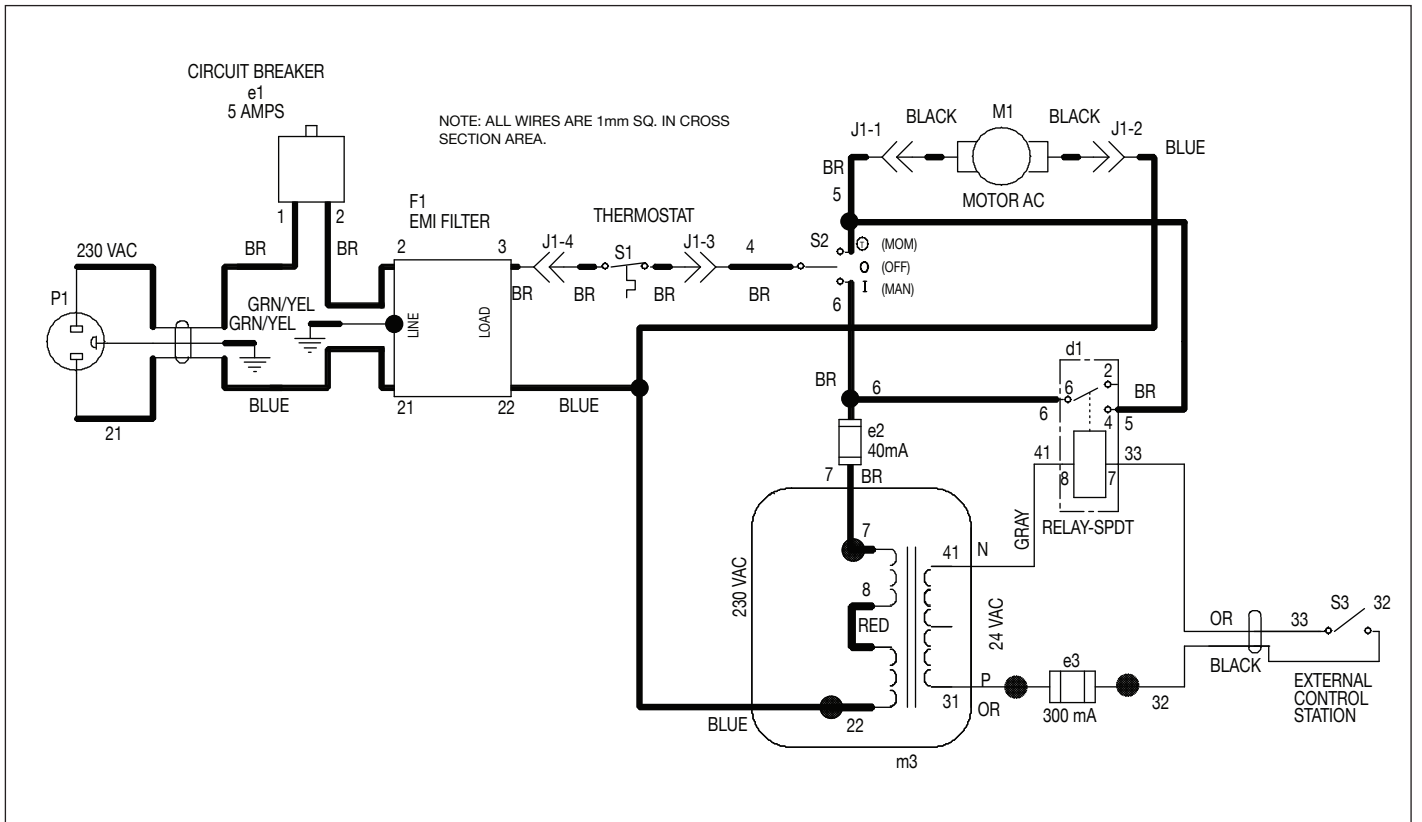

Figure 15, Electrical Schematic, 230V Models

Figure	Item No.	Torque Specification and/or Assembly Notes
1	18	Apply 1 drop Loctite #242 to threads. Torque to 12-18 in-lbs (1,4-2,0 Nm).
1	154	Torque to 27-31 in-lbs (3,1-3,5 Nm).
1	129	Torque to 19-21 ft-lbs (2,1-2,4 Nm).
1	Note 1	Install bearing, Item 117, flush to 0.010" (2,54 mm) recessed from surface.
2	10	Trim wire length to 9 to 10 inches (228-254 mm) before attaching pins (item 10). Then insert into item 24.
2	15	Torque to 27-31 in-lbs, (3,1-3,5 Nm).
2	58	Torque to 35-42 in-lbs (4,0-4,7 Nm).
4	15	Torque to 27-31 in-lbs (3,1-3,5 Nm).
4	109	Torque to 14-16 ft-lbs, dry (19,0-21,7 Nm).
4	121	Torque to 16-19 ft-lbs, dry (21,7-25,8 Nm).
4	143	Align tube to face mesh and splash lubricate upper needle bearing.
4	146	Seat must be coined prior to assembly.
4	148	Assemble with Loctite #545.
4	150	Relief valve setting should be from 250 to 400 psi (17,3 to 27,9 bar).
4	190	Assemble with Loctite #609.
4	Note 2	Stake threads after setting pressure.
7	5	Torque to 47-53 in-lbs (5,3-6,0 Nm). Use Loctite #242 on item #5.
7	8	Torque to 9-12 in-lbs (1,0-1,3 Nm).
7	24	Attach to receptacle on shroud.
7	50	Torque to 11-13 ft-lbs (14.9-17,6 Nm).
7	51	Torque to 11-13 ft-lbs (14.9-17,6 Nm).
13	5	Torque the switch terminal screws and the switch mounting nut to 4.0-4.5 in-lbs (0,45-0,50 Nm).
13	7	Torque to 14-16 in-lbs (1.6-1.8 Nm).



www.enerpac.com