

▼ TWMP503



## TWMP503, Torque Wrench Moly Paste

- Enerpac 503 Moly Paste reduces friction on threaded fasteners – bolts, nuts and studs
- The low and uniform friction coefficient of 0.06 (torque coefficient, K, of 0.11) creates reliable assembly conditions
- This lubricant stays in place through heat, load and vibration to ensure trouble-free disassembly from -20° F to 750° F (-29° C to 400° C)
- 4 lbs. (1,8 kg) container

for  
**RSL Series**



## ERA-Series, Extended Reaction Arms

For Torque Wrench Model No.	Model Number	Dimensions (in)					(lbs)
		A	B	C	D	E	
RSL1500	ERA15114	3.42	5.71	7.68	1.14	1.42	1.98
	ERA15228	4.45	7.13	9.06	1.14	1.42	3.97
	ERA15342	5.47	8.90	10.87	1.14	1.42	5.95
	ERA15456	6.46	9.29	11.26	1.14	1.42	7.94
	ERA15570	7.44	11.30	13.27	1.14	1.42	9.92
RSL3000	ERA30114	4.13	7.68	10.12	1.34	1.61	5.95
	ERA30228	5.16	9.09	11.54	1.34	1.61	7.94
	ERA30342	6.14	10.47	12.91	1.34	1.61	9.92
	ERA30456	7.13	11.89	14.66	1.34	1.61	11.90
RSL5000	ERA50114	5.16	8.19	11.18	1.73	1.89	9.04
	ERA50228	6.14	9.57	12.60	1.73	1.89	11.02
	ERA50342	7.13	10.98	13.98	1.73	1.89	13.01
	ERA50456	8.15	12.37	15.39	1.73	1.89	15.00
RSL11000	ERA110114	4.92	8.62	11.65	2.01	2.32	13.89
	ERA110228	5.91	10.04	13.06	2.01	2.32	16.09
	ERA110342	6.93	11.46	14.45	2.01	2.32	18.08
	ERA110456	7.91	12.83	15.83	2.01	2.32	20.06
RSL28000	ERA280228	6.73	13.19	16.18	2.24	3.50	24.91
	ERA280342	7.76	14.57	17.60	2.24	3.50	30.00

NOTE: Extended Reaction Arms for RSL8000 and RSL19000 are available on request.

- Only to be used on RSL-drive units with RSQ-square drive wrenches
- Used in place of standard reaction arm
- Lightweight interchangeable design
- Full torque rated

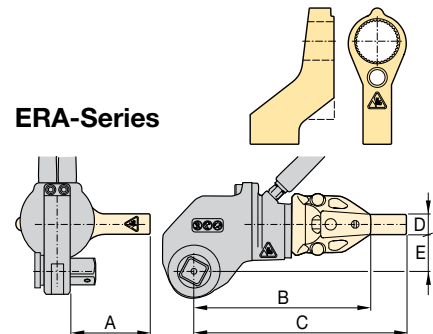

## ERT-Series, Extended Reaction Tubes

For Torque Wrench Model No.	Model Number	Dimensions (in)			Wt. (lbs)
		A	B	Ø C	
RSL1500	ERT152	6.18	2.01	2.24	1.98
	ERT156	10.20	5.98	2.24	3.53
	ERT159	13.19	9.02	2.24	5.51
	ERT1512	16.18	12.01	2.24	7.50
	ERT1524	28.19	24.02	2.24	14.78
RSL3000	ERT3012	16.89	12.01	2.76	6.61
	ERT3024	28.90	24.02	2.76	13.01
RSL5000	ERT5012	17.76	12.01	3.50	12.35
	ERT5024	29.76	24.02	3.50	24.91
RSL11000	ERT1106	12.99	5.98	3.74	4.63
	ERT11012	19.02	12.01	3.74	9.04
	ERT11018	25.00	17.99	3.74	13.45
	ERT11024	30.98	24.02	3.74	18.52
RSL19000	ERT19024	31.50	24.02	5	36.82
RSL28000	ERT2806	13.82	5.98	5	7.94
	ERT28012	19.80	12.01	5	16.09
	ERT28018	25.79	17.99	5	24.03
	ERT28024	31.81	24.02	5	36.60

NOTE: Extended Reaction Tubes for RSL8000 are available on request.

- Only to be used on RSL-drive units with RLP-hexagon cassettes
- Used in place of standard reaction arm
- One-piece steel design, durable and simple
- Increases tool fit in restricted access areas
- Full torque rated

