



G3
Torque



G3171T Shown

- Reservoir Capacity▶ 1 - 2.5 gallons
- Weight▶ 57 - 69 lbs.
- Maximum Pressure▶ 10,000 psi

- ▶ Heavy Duty bolting pump is ideal for use with small to mid-sized torque wrenches.
- ▶ High performance two-stage pump provides higher cross-over pressure for faster cycle times and tool operation; 46 cubic inches / minute @ 10,000 PSI.
- ▶ Powered by a 115V - 60Hz, 1-1/8 hp universal motor.

TORQUE HOSES - page 89



Heavy duty, thermo-plastic torque wrench hoses to meet your requirements.

TORQUE WRENCHES -



Torque wrenches available in lightweight square drive, or low clearance wrenches.

G3 Bolting Pump Factory Installed Options

For ordering, add option letter to end of the model number.

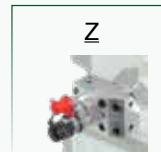

Multi-Port Manifold

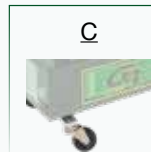

Caster Kit



Roll Cage

The ease of operation and mobility from the G3 bolting pump was needed to repair the massive chuck on this CNC machine. ▼

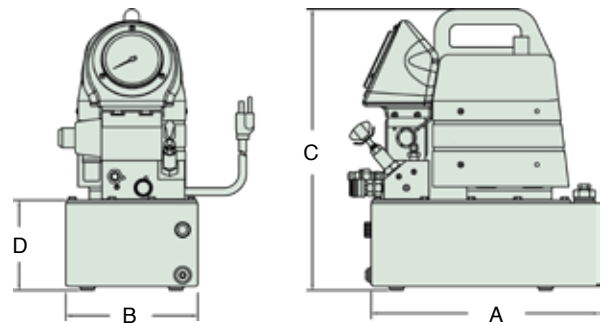

Reservoir (Gallons)	A	B	C	D
	(in)	(in)	(in)	(in)
1.5	15.13	8.75	19	5.96
2.5	17	9.75	19	5.96

* For 230 VAC pump use "2" in the 3rd character of the model number. Motor specifications 0,8 kw single phase, 10 amps @ 230 VAC.

Model	Pressure Rating (psi) Stages		Output Flow (cu.in./min.) Stages		Motor Spec.		Valve Type	Pendant Control	Usable Oil (Gallons)	Weight (lbs)
	1st	2nd	1st	2nd	(vac)	(amps)				
G3171T	1,100	10,000	525	46	115	16	4W, 2P	Motor / Solenoid	1	57
G3172T	1,100	10,000	525	46	115	16	4W, 2P	Motor / Solenoid	1.5	62
G3173T	1,100	10,000	525	46	115	16	4W, 2P	Motor / Solenoid	2.5	69

Bolting Products