

L4174 Rev. D 01/21

Table of Contents:

Section	Page
1.0 IMPORTANT RECEIVING INSTRUCTIONS	1
2.0 SAFETY	1
3.0 CONFORMANCE TO NATIONAL AND INTERNATIONAL STANDARDS	3
4.0 PRODUCT DESCRIPTION	3
5.0 LIFTING THE CYLINDER	3
6.0 SETUP	4
7.0 AVOIDING SIDE LOAD	5
8.0 OPERATION	5
9.0 INSPECTION, MAINTENANCE & STORAGE	5
10.0 RELIEVING TRAPPED PRESSURE	6
11.0 TROUBLESHOOTING	6
12.0 PRODUCT DATA	7

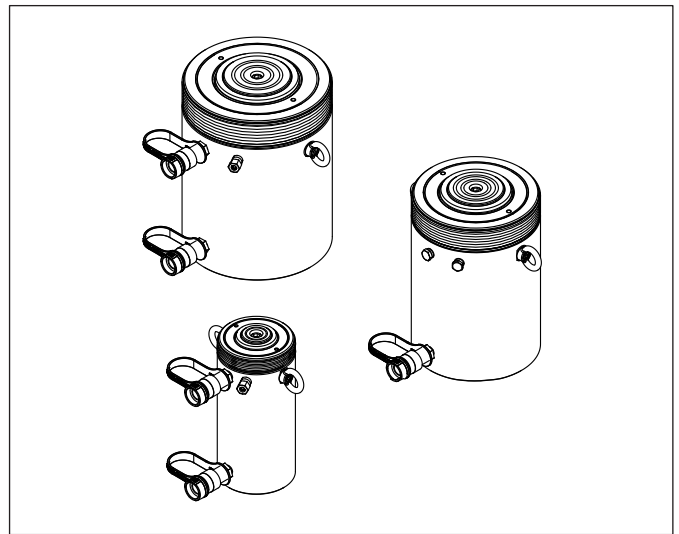

Safety Alert Symbols are used in conjunction with certain Signal Words that call attention to safety messages or property damage messages and designate a degree or level of hazard seriousness. The Signal Words used in this manual are WARNING, CAUTION and NOTICE.

1.0 IMPORTANT RECEIVING INSTRUCTIONS

Visually inspect all components for shipping damage. Shipping damage is not covered by warranty. If shipping damage is found, notify carrier at once. The carrier is responsible for all repair and replacement costs resulting from damage in shipment.

2.0 SAFETY

2.1 Introduction

Read all instructions carefully. Follow all recommended safety precautions to avoid personal injury as well as damage to the product and/or damage to other property. Enerpac cannot be responsible for any damage or injury from unsafe use, lack of maintenance or incorrect operation. Do not remove warning labels, tags, or decals. In the event any questions or concerns arise, contact Enerpac or a local Enerpac distributor for clarification.

If you have never been trained on high-pressure hydraulic safety, consult your distributor or service center for information about an Enerpac Hydraulic Safety Course.

This manual follows a system of safety alert symbols, signal words and safety messages to warn the user of specific hazards. Failure to comply with these warnings could result in death or serious personal injury, as well as damage to the equipment or other property.



The **Safety Alert Symbol** appears throughout this manual. It is used to alert you to potential physical injury hazards. Pay close attention to Safety Alert Symbols and obey all safety messages that follow this symbol to avoid the possibility of death or serious personal injury.



Indicates a hazardous situation that, if not avoided, **could** result in death or serious personal injury.



Indicates a hazardous situation that, if not avoided, **could** result in minor or moderate personal injury.



Indicates information considered important, but not hazard related (e.g. messages relating to property damage). Please note that the Safety Alert Symbol will **not** be used with this signal word.

2.2 Hydraulic Cylinder Safety Precautions (HCG-Series and HCR-Series)



Failure to observe and comply with the following precautions could result in death or serious personal injury. Property damage could also occur.

- Read and completely understand the safety precautions and instructions in this manual before operating the cylinder or preparing it for use. Always follow all safety precautions and instructions, including those that are contained within the procedures of this manual.
- Operating procedures will vary, depending on the system arrangement. Always read, follow and completely understand all manufacturer's instructions when operating pumps, valves and all other devices used with the cylinders. Follow all safety precautions contained in the manufacturer's manuals.

- Always wear appropriate personal protective equipment (P.P.E.) when operating hydraulic equipment. Be sure to wear eye protection, work gloves and protective clothing. Use of additional P.P.E. safety items such as dust mask, non-skid safety shoes, hard hat, and hearing protection (used as appropriate for the conditions) will reduce the chance of personal injuries. The use of these items may also be required by local regulations or laws.
- Do not handle pressurized hoses. Escaping oil under pressure can penetrate the skin. If oil is injected under the skin, see a doctor immediately.
- Do not pressurize disconnected couplers.
- Use hydraulic cylinders only in a coupled system. Never use a cylinder with uncoupled couplers.
- Do not remove or disable the pump relief valve.
- Do not remove or disable the cylinder relief valve (if equipped).
- The system operating pressure must not exceed the pressure rating of the lowest rated component in the system.
- Install pressure gauge(s) in the system to monitor operating pressure. It is your window to see what is happening in the system.
- Never set a relief valve to a higher pressure than the maximum rated pressure of the pump and cylinder. If ratings are different, relief valve setting should not exceed the setting of the lowest rated component (pump or cylinder).
- The HCG-Series and HCR-Series cylinders are designed for a maximum working pressure of 10150 psi [700 bar]. Do not connect a pump with a higher pressure rating to these cylinders.
- Do not exceed equipment ratings. Never attempt to lift a load weighing more than the rated capacity of the cylinder. Overloading may cause equipment failure and possible personal injury.
- Be sure setup is stable before lifting load. Cylinders should be located on a firm and level surface capable of supporting the full load.
- Where applicable, use a cylinder base plate to provide added stability. If desired, the cylinder can be bolted to the base plate, using the bolt holes in the bottom of the cylinder base. (Note: An accessory base plate is available from Enerpac for the HCG-50 and HCR-50 Series models. Base plate must be user-fabricated for all other models).
- Do not weld, drill or otherwise modify a cylinder to attach a base plate or other support unless approved in writing by the Enerpac Engineering Department. Use only the provided bolt holes.
- Always perform a visual inspection of the cylinder before placing it into operation. If any problems are found, do not use the cylinder. Have the cylinder repaired and tested by an Enerpac Authorized Service Center before it is returned to service.
- Never use a cylinder that is leaking oil. Do not use a cylinder that is damaged, altered or in need of repair.
- Always lift the cylinder using a hoist, crane or other suitable lifting device of sufficient rated capacity. Use only the supplied cylinder lifting eyes to attach the cylinder to the lifting device. Replace any missing or damaged lifting eyes.
- Allow only trained and experienced personnel to supervise and perform lifting and lowering procedures.
- Be certain that no persons are working on or near any cylinders before lifting or lowering of the load begins. Alert all personnel in advance that lifting or lowering is about to occur.
- Use suitable cribbing of rigid construction to hold loads.
- Never use a hydraulic cylinder as a shim or spacer in any lifting or pressing application.
- A cylinder when used as a load lifting device, should never be used as a load holding device. After the load has been raised or lowered, it always must be cribbed mechanically.
- Be certain that the load is centered and covers the entire plunger saddle surface. Avoid situations where loads are not directly centered on the plunger saddle. The load may slip or fall, causing potential danger.
- Lift only dead weight loads. Avoid lifting live weight loads.
- Be especially careful when lifting loads such as partially filled storage tanks, in which the center of gravity could move or shift during lifting. Be aware that the distribution of some loads can change quickly and without warning.
- Do not use the cylinder to lift people. Do not allow people to be on top of the load during lifting or lowering.
- Keep all personnel clear of the work area while lifting or lowering is in progress. To avoid personal injury, keep hands and feet away from cylinder and load during operation.
- Maintain communication with the operator at all times during lifting or lowering to avoid accidents. Use hand signals, two-way radios or other appropriate forms of communication (as required by applicable laws and regulations) if the load is not visible to the operator.
- Operate pump and valve as required to ensure that the load is lifted and lowered evenly and at a controlled rate.
- Closely watch the load at all times during lifting and lowering. Stop lifting or lowering immediately if the load becomes unstable or appears to be lifting or lowering unevenly.
- Stay clear of loads supported only by hydraulics. As required, follow the lifted load with cribbing.
- Always be certain that hydraulic pressure is fully relieved and that the load is fully removed from the cylinder(s) before disconnecting hydraulic hoses, loosening hydraulic fittings, or performing any cylinder disassembly or repair procedures.



Failure to observe and comply with the following precautions could result in minor or moderate personal injury. Property damage could also occur.

- Be careful to avoid damaging hydraulic hoses. Avoid sharp bends and kinks when routing hydraulic hoses. Do not exceed the minimum bend radius specified by the hose manufacturer. Using a bent or kinked hose will cause severe back-pressure. Sharp bends and kinks will internally damage the hose, leading to premature hose failure.
- Do not drop heavy objects on hoses. A sharp impact may cause internal damage to hose wire strands. Applying pressure to a damaged hose may cause it to rupture.
- Do not lift hydraulic equipment by the hoses or couplers. Use the cylinder lifting eyes and appropriately rated lifting equipment.
- Keep hydraulic equipment away from flames and heat. Excessive heat will soften packings and seals, resulting in fluid leaks. Heat also weakens hose materials and packings.
- For optimum performance, do not expose hydraulic equipment to temperatures of 150°F [65°C] or higher. Protect all hydraulic equipment from weld spatter.
- Immediately replace worn or damaged parts with genuine Enerpac parts. Enerpac parts are designed to fit properly and to withstand high loads. Non-Enerpac parts may break or cause the product to malfunction.



- Hydraulic equipment must only be serviced by a qualified hydraulic technician. For repair service, contact the Enerpac Authorized Service Center in your area.
- To help ensure proper operation and best performance, use of Enerpac oil is strongly recommended.

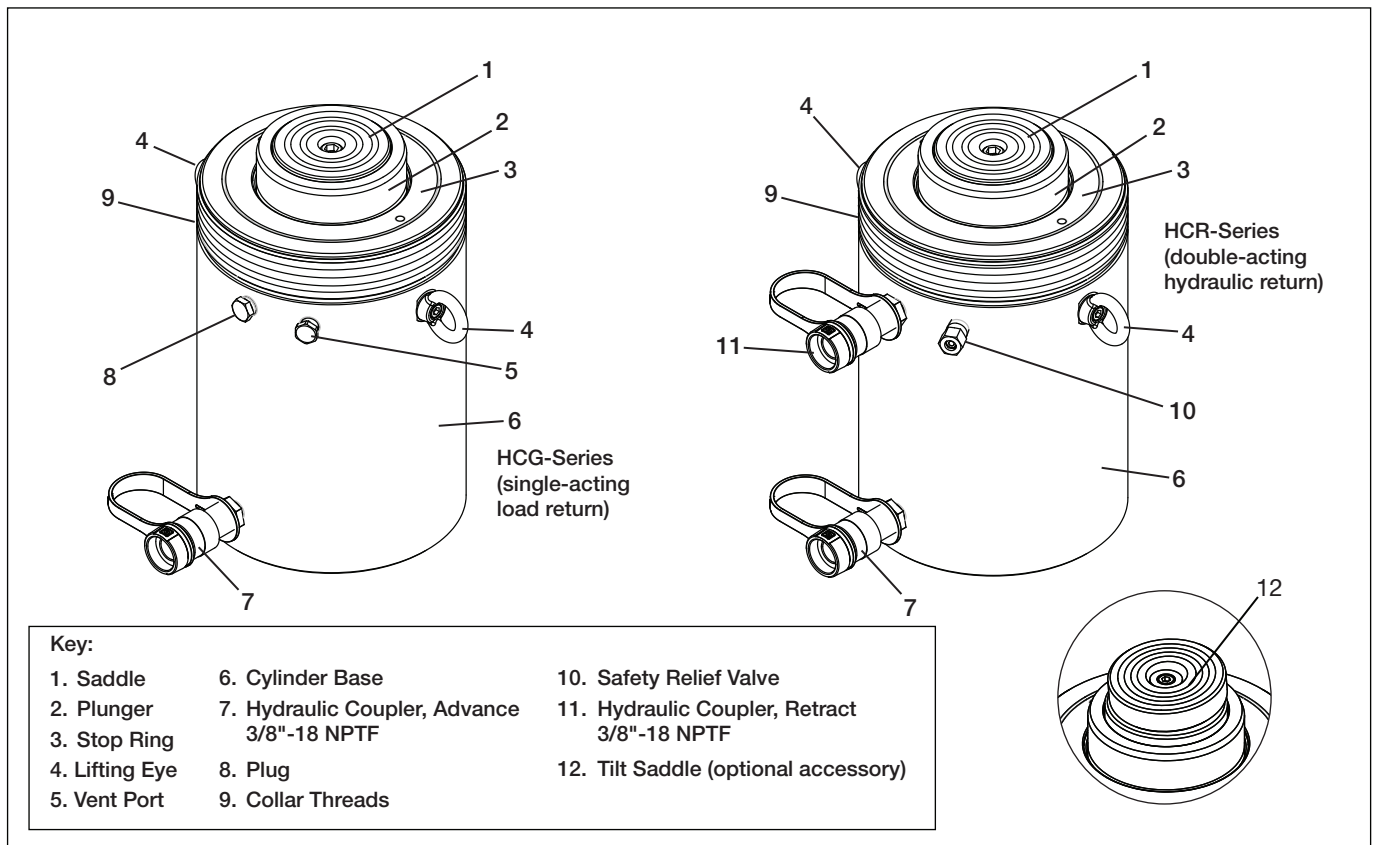

Figure 1, Major Features and Components, HCG-Series and HCR-Series Hydraulic Cylinders (Typical)

2.3 Additional References

Consult the applicable industry and/or government standards in your country or region for additional safety precautions and work rules applicable to hydraulic cylinders, jacks and other similar lifting equipment.

In the USA, refer to the following publications:

- Code of Federal Regulations - Title 29 Occupational Safety and Health Standards (U.S. Government Publishing Office, 732 North Capitol Street, NW, Washington, DC 20401-0001. www.gpo.gov).
- ASME B30.1 Standards - Jacks (American Society of Mechanical Engineers, Two Park Avenue, New York, NY 10016-5990. www.asme.org).

In the European Union, refer to the standards and directives listed in the product's EU Declaration of Incorporation. A copy of this document is packed separately with the cylinder.

3.0 CONFORMANCE TO NATIONAL AND INTERNATIONAL STANDARDS

CE Enerpac declares that this product has been tested and conforms to applicable standards and is compatible to all CE Requirements. A copy of an EU Declaration of Incorporation is enclosed with each shipment of this product.

4.0 PRODUCT DESCRIPTION

Enerpac HCG-Series and HCR-Series high tonnage hydraulic cylinders are an ideal solution for a wide variety of commercial and industrial lifting applications.

HCG-Series models are single-acting with hydraulic advance and load return. Manual force will be required to retract the plunger if no load is present.

HCR-Series models are double-acting with hydraulic advance and return. The hydraulic return feature allows greater control during lowering and provides positive retraction of the plunger. Note that the HCR-Series cylinders are not designed for pulling applications.

Capacities range from 62 to 1196 US tons [550 to 10644 kN]. Refer to the product data markings on the cylinder base for the capacity rating of your cylinder model.

All standard production HCG and HCR cylinders are designed for 10150 psi [700 bar] maximum working pressure.

A hardened grooved saddle is standard equipment on all models. A user-installable tilt saddle is available as an optional accessory.

Refer to Section 12 of this manual for cylinder weights, oil volumes, dimensions and additional specifications.

5.0 LIFTING THE CYLINDER

All cylinders are equipped with TWO pre-installed lifting eyes. Always use BOTH lifting eyes when hoisting the cylinder.

Lifting straps or chains must be positioned at an angle where they will not interfere with the cylinder base. Use of a spreader bar is recommended. See Figure 2.

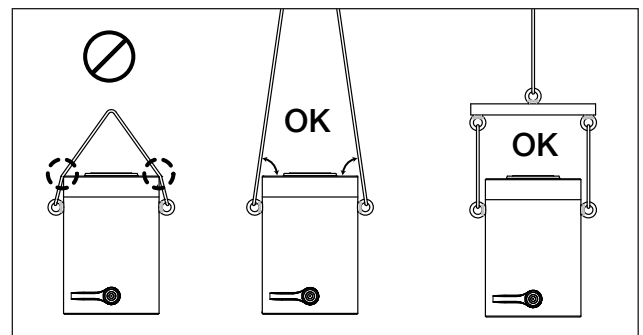

Figure 2, Lifting Arrangements (typical)

6.0 SETUP

6.1 Hydraulic Pump Requirements

Hydraulic pumps are sold separately and are not included with the cylinders.

A hand-operated hydraulic pump can be used to operate a smaller HGC or HCR-Series cylinder. However, a large size cylinder (or a series of coupled cylinders) will typically require the use of an electric, air or gas powered hydraulic pump.

Whichever type of pump is used, be certain that the pump reservoir is capable of holding a sufficient amount of hydraulic oil to operate the cylinder (or set of cylinders) to full extension.

If used with HCG-Series single-acting cylinders, the pump must be equipped with a pressure release valve. If used with HCR-Series double-acting cylinders, the pump must be equipped with a four-way directional control valve. These valves may be either manual or remote operated.

The pump must also be equipped with a separate safety pressure relief valve that opens if the system working pressure exceeds 10150 psi [700 bar]. Verify that the pump safety relief valve is adjusted to the proper setting before using the pump with the cylinder(s).

6.2 Hydraulic Oil Requirements

Use of Enerpac HF Series ISO 32 hydraulic oil is recommended. Enerpac HF oil is available at your local Enerpac Distributor or Authorized Service Center.

NOTICE

- Failure to use the correct oil type (high-quality ISO 32 hydraulic oil) may result in damage to cylinder hydraulic components and will void the product warranty.
- Be sure that the oil is clean. The oil cleanliness should be maintained to a maximum level of 18/16/13 per the ISO 4406 standard. If the oil develops a milky, cloudy or dark appearance, it should be changed immediately.
- To avoid overfilling and possible equipment damage, add oil to the pump reservoir only after all cylinder plungers are completely retracted and system pressure is released.
- When using a hand-operated pump to power the cylinder(s), it is permissible to use a high-quality brand of ISO 15 hydraulic oil. The lower oil viscosity will result in reduced pumping effort, especially in cold weather conditions.

6.3 Tilt Saddle (optional accessory)

The Enerpac CATS Series tilt saddle is available as an optional accessory. If ordered with a HGC or HCR-Series cylinder, the tilt saddle is shipped separately and must be installed on the cylinder before use, as described in the following procedure.

Install the tilt saddle as described in the following steps. Refer to Figure 3 for installation details.

1. Remove the existing center bolt and standard saddle from the plunger bore.
2. Inspect the mating surfaces of the plunger bore and the tilt saddle lower half. Mating surfaces must be free of dust, dirt, moisture or corrosion.
3. Apply service-removable thread locking compound (Loctite® 243 or equivalent) to the threaded stud at the bottom of the tilt saddle.
4. By hand, gently engage the threads of the threaded stud with the threads of the tapped hole at the center of the plunger. Check for free movement. Be sure the stud is not cross-threaded.
5. Rotate the tilt saddle clockwise several turns, until it is fully seated in the plunger bore.

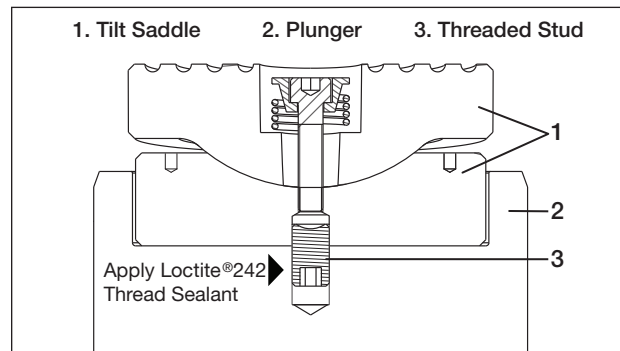

Figure 3, CATS Series Tilt Saddle Accessory (typical)

6.4 Hydraulic Connections

The HCG series cylinders are equipped with one 3/8"-18 NPTF female coupler. This coupler provides hydraulic flow for both advance and retract functions.

The HCR series cylinders are equipped with two 3/8"-18 NPTF female couplers, one for advance side hydraulic flow and one for retract side hydraulic flow.

Refer to Figure 1, items 7 and 11 for locations.

Be certain that all couplers are fully connected, so that hydraulic flow is not blocked or restricted.

All hoses, fittings and other hydraulic components in the circuit must be rated for at least 10150 psi [700 bar] operation.

NOTICE HCR-Series cylinders are double-acting. In both operational modes, return oil flow (from the non-pressurized side of the cylinder) must be directed back to the hydraulic reservoir. Check for proper flow before placing the equipment into operation.

6.5 Air Removal

Trapped air must be removed from the hydraulic cylinder and hose before placing the system into operation. If multiple cylinders are to be used, it is recommended that air be removed from each cylinder individually. Refer to the following procedure:

1. Position the pump so it is located *higher* than the cylinder.
2. Place the cylinder in the vertical position, with the base located on a flat and level surface. Be sure that there is no load on the plunger.
3. Using the hydraulic pump and valve, advance and retract the plunger as required to remove trapped air. Refer to the procedure for your cylinder series:

HCG-Series models: Fully advance the plunger, being careful to avoid pressure build-up at full extension. Completely relieve hydraulic pressure, then manually push the plunger into the cylinder base until it is fully retracted. Repeat this process until the plunger advances smoothly. Use of a hydraulic pump equipped with a vacuum valve will help aid plunger retraction.

HCR-Series models: Fully advance and retract the plunger, being careful to avoid pressure build-up at full extension and full retraction. Repeat this process until plunger motion is smooth in both directions.

4. Fully retract the plunger after completing air removal procedures. Check oil level in pump hydraulic reservoir. Add oil if oil level is low.
5. Repeat steps 1 through 4 for all cylinders to be used in the hydraulic circuit.

6.6 Cylinder Base Support

Be certain to provide adequate support for the cylinder base. All HCR and HCG-Series cylinders require a flat and stable lifting surface that is capable of supporting the load without settling. A steel plate or steel bars of appropriate size should be placed between the cylinder base and the ground or other lifting surface. See Figure 4.

CAUTION Use of HCG-Series or HCR-Series cylinders on surfaces such as sand, mud or dirt may result in loss of load and/or damage to cylinder.

Base mounting holes are provided on all models. Refer to Section 12.3 for mounting hole locations and dimensions. Mounting bolts are not included with the cylinder and must be provided by the user.

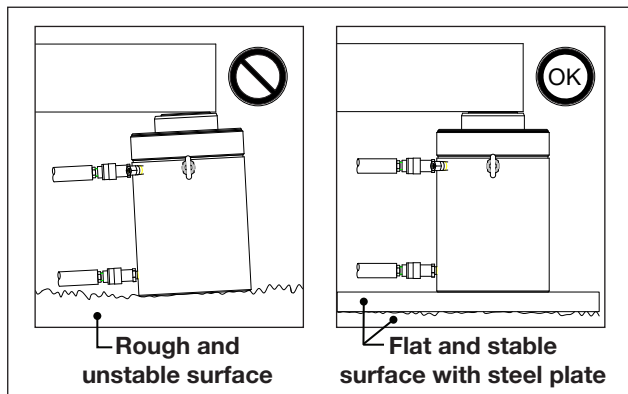

Figure 4, Cylinder Base Support

7.0 AVOIDING SIDE LOAD

Plan ahead to eliminate the presence of side load forces (offset loading) when using hydraulic cylinders. Side load can occur as a result of one or more of the following conditions:

- An eccentric load on the plunger.
- A horizontal load on a structure.
- A shifting center of gravity.
- Structure and/or cylinder misalignment.
- Non-synchronized lifting actions.
- Non-stable cylinder base support.

It is understood that some side load will occur in many lifting situations. However, the user should do everything possible to minimize or eliminate this condition.

The possibility of side load can be reduced by ensuring that the cylinder base is located on a flat and hard surface, capable of supporting the cylinder and the load without settling.

To help reduce the effects of side load that cannot be eliminated, use of the CATS Series tilt saddle is strongly recommended.

The CATS series tilt saddle helps compensate for initial misalignment of the load and the saddle surface. It reduces saddle edge loading, which can result in an undesirable off-center load being applied to the plunger. This item is available as an optional accessory for all HCG-Series and HCR-Series cylinders. Refer to Section 6.3 for additional information.

8.0 OPERATION

Operation procedures will vary, depending on hydraulic pump type, valve configuration and other factors. For detailed operating instructions and related information, refer to the instruction sheet included with your pump. Also follow the additional instructions and precautions contained in sections 8.1 through 8.4 of this manual.

If using multiple HCR-Series cylinders: Without load, verify that all plungers advance and retract in the same direction when the control valve is shifted. If necessary, relieve pressure and properly reconnect any reversed hydraulic hoses.

NOTICE It is mandatory that the operator has a full understanding of all instructions, safety precautions and applicable safety regulations before operating any high force hydraulic equipment. If questions or concerns, contact your local Enerpac Distributor or Authorized Service Center.

8.1 Operation - HCG-Series

To advance: Operate pump and valve so that pressurized oil flow is directed in a controlled rate from the pump reservoir to the advance coupler of the cylinder.

To retract: Operate pump and valve so that oil flow is directed at a controlled rate from the cylinder advance coupler back to the pump reservoir. Note that additional hydraulic components may be required to control the rate at which the plunger retracts under load.

NOTICE HCG-Series cylinders contain no plunger return spring. External force will be required to fully retract an HCG-Series cylinder if it is not under load. Use of a hydraulic pump equipped with a vacuum valve will help aid cylinder retraction.

8.2 Operation - HCR-Series

To advance: Operate pump and valve so that pressurized oil flow is directed from the pump reservoir to the advance coupler of the cylinder.

To retract: Operate pump and valve so that pressurized oil flow is directed from the pump reservoir to the retract coupler of the cylinder. Note that additional hydraulic components may be required to control the rate at which the plunger retracts under load.

8.3 Vent Port (HCG-Series Only)

On HCG-Series models, a built-in vent port provides vacuum relief and pressure equalization for the cylinder plunger cavity. The vent port is located near the top of the cylinder base. See Figure 1, item 5.

Periodically check that the vent port passage is free of dirt or other obstructions.

8.4 Retract Side Safety Relief Valve (HCR-Series Only)

HCR-Series models include a retract side safety relief valve. It is located near the top of the cylinder base. See Figure 1, item 10.

The valve is designed to relieve retract chamber pressure in the event that hydraulic flow is directed to the advance side of the cylinder while the retract side hose is disconnected. It is factory set at approximately 862-896 bar [12500-13000 psi].

WARNING Do not remove, alter or disable the retract side safety relief valve. Do not readjust the valve setting. Failure to observe this instruction may result in possible catastrophic failure of the cylinder. Serious personal injury could result.

9.0 INSPECTION, MAINTENANCE & STORAGE

- Periodically check the hydraulic system for loose connections leaks and obvious problems. Replace any damaged components immediately.
- Monitor the oil temperature during operation. Do not exceed oil temperatures above 150°F [65°C].
- Install dust cap(s) and plug(s) after the hydraulic hoses are disconnected from the cylinder.
- Keep all hydraulic components clean.
- Periodically check the tilt saddle (if equipped) for free movement. If required, disassemble, clean and lubricate the tilt saddle. Use white lithium grease.
- Change the hydraulic oil at the recommended interval shown in the pump instruction sheet. Change the oil immediately if

contamination is suspected.

- Store cylinders in the upright position, in a clean, dry and secure location. Keep stored cylinders and hoses away from heat and direct sunlight.
- If repairs are required, refer to the Enerpac website for the repair parts sheet applicable to your cylinder model.

NOTICE Hydraulic equipment must only be serviced by a qualified hydraulic technician. For repair service, contact the Enerpac Authorized Service Center in your area.

10.0 RELIEVING TRAPPED PRESSURE

Hydraulic pressure can sometimes become trapped within a hydraulic cylinder. This condition can occur in both single and double-acting cylinders, but is most likely to happen in a double-acting cylinder that has been exposed to changing ambient temperatures.

A common indication of trapped pressure is when mating hose and cylinder couplers will not engage, or are unusually difficult to engage.

If a trapped pressure condition is suspected, always use the Enerpac model CT-604 coupler bleed tool (available from your Enerpac distributor) to safely relieve any remaining pressure.

WARNING Never attempt to relieve trapped hydraulic pressure within the cylinder by loosening a coupler on the cylinder base.

Trapped hydraulic pressure can cause a loosened coupler to dislodge unexpectedly with great force. Serious personal injury or death will result if the coupler becomes a projectile and strikes persons working in the area.

A sudden escape of pressurized hydraulic oil may also occur if a coupler is loosened while trapped hydraulic pressure is present. Serious personal injury or death could result if a high pressure oil stream penetrates the skin.

Use only the Enerpac CT-604 coupler bleed tool to relieve trapped hydraulic pressure within the cylinder.

WARNING Never use a hammer and punch (or other similar method) to unseat a coupler check ball that is under pressure. Serious personal injury or death could result due to the sudden and uncontrolled escape of high pressure oil. Use only the Enerpac CT-604 coupler bleed tool to relieve trapped pressure within the cylinder.

11.0 TROUBLESHOOTING

Refer to the troubleshooting guide when diagnosing cylinder operational problems. Please note that the troubleshooting guide is not all-inclusive, and should be considered only as an aid to help diagnose the most common possible problems.

For repair service, contact your nearest Enerpac Authorized Service Center. As required, also refer to the troubleshooting information provided with your hydraulic pump or power unit.

<i>Troubleshooting Guide</i>		
Symptom	Possible Cause	Solution
1. Plunger will not advance.	a. Pump release valve open.	Close pump release valve.
	b. Directional control valve not in proper position.	Shift directional control valve to proper position.
	c. Coupler not fully tightened.	Tighten coupler.
	d. Pump oil level is low.	Add oil to pump reservoir as required. See Section 6.2.
	e. Pump malfunctioning.	Repair or replace pump as required.
	f. Cylinder load rating too low for application.	Use a cylinder with a higher load rating.
	g. Cylinder seals leaking.	Repair or replace cylinder.
2. Plunger advances only part way.	a. Oil level in pump is low.	Add oil to pump reservoir as required. See Section 6.2.
	b. Coupler is not fully tightened.	Tighten coupler.
	c. Cylinder plunger binding.	Repair or replace cylinder.
3. Plunger advances erratically.	a. Air in hydraulic system.	Remove air from hydraulic system. See Section 6.5.
	b. Cylinder plunger binding.	Repair or replace cylinder.
4. Plunger advances more slowly than normal.	a. Leaking connection.	Repair leaking connection.
	b. Coupler not fully tightened.	Tighten coupler.
	c. Pump malfunctioning.	Repair or replace pump as required.
5. Plunger advances, but will not hold.	a. Pump malfunctioning.	Repair or replace pump as required.
	b. Leaking connection.	Repair leaking connection.
	c. Incorrect system set-up.	Check hose connections at pump and cylinders.
	d. Cylinder seals leaking.	Repair or replace cylinder.
6. Cylinder leaks oil.	a. Worn or damaged cylinder seals.	Repair or replace cylinder.
	b. Internal cylinder damage.	Repair or replace cylinder.
	c. Loose connection.	Tighten or repair connection.
7. Plunger will not retract or retracts more slowly than normal.	a. Pump release valve closed.	Open pump release valve.
	b. Directional control valve not in proper position.	Shift directional control valve to proper position.
	c. Pump reservoir is overfilled.	Drain oil from pump reservoir as required.
	d. Improper hose connections.	Check hose connections.
	e. Narrow hose restricting oil flow.	Replace with larger diameter hose.
	f. Internal cylinder damage.	Repair or replace cylinder.
8. Oil leakage from external relief valve.	a. Coupler not fully tightened.	Tighten coupler.
	b. Restriction in return line.	Remove restriction from return line.
	c. Relief valve setting incorrect.	Check relief valve setting.
	d. Relief valve damaged or contaminated.	Repair or replace relief valve.

12.0 PRODUCT DATA

Models rated at 150 US Tons [1497 kN] or lower.

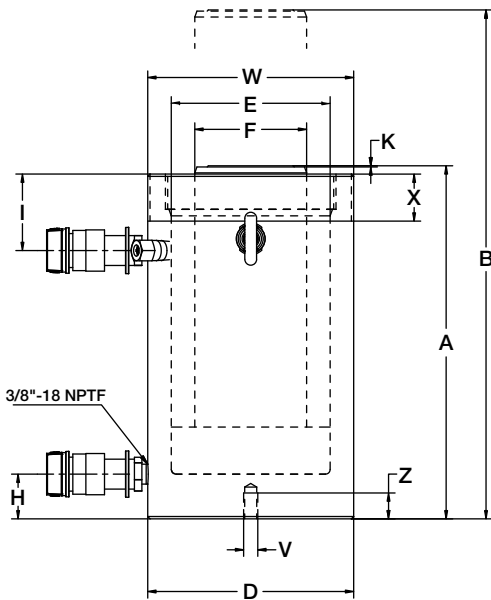
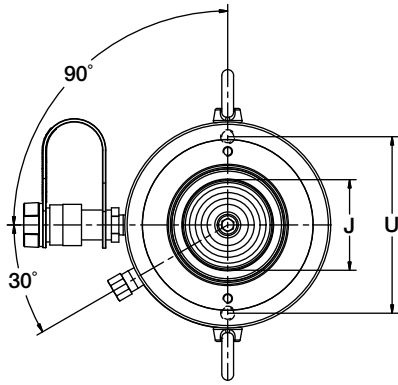

Models rated at 200 US Tons [1985 kN] or higher.

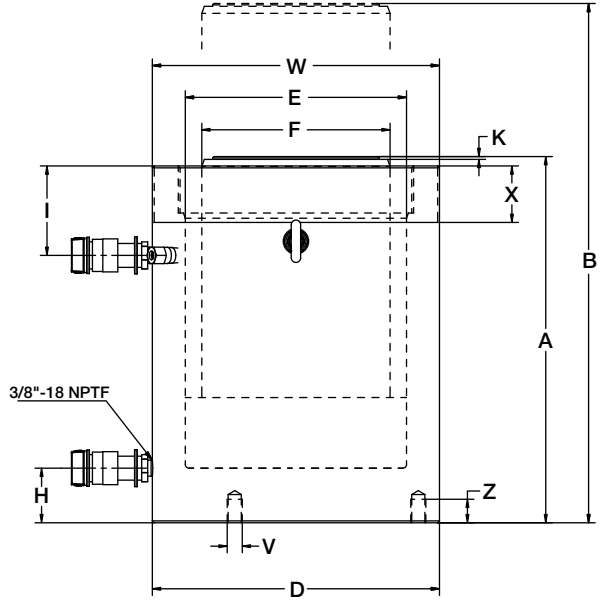
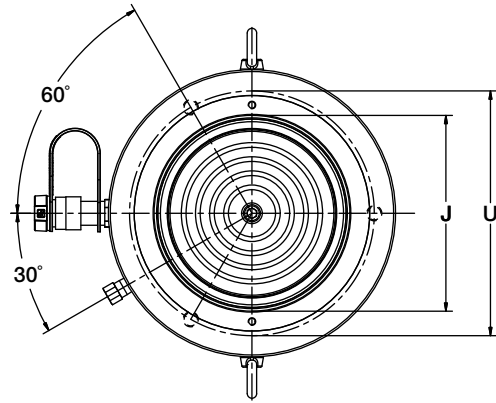

Refer to Sections 12.1, 12.2 and 12.3 for the dimensions applicable to your cylinder model. Use this graphic as a reference.

Tilt Saddle - Optional Accessory, All Models

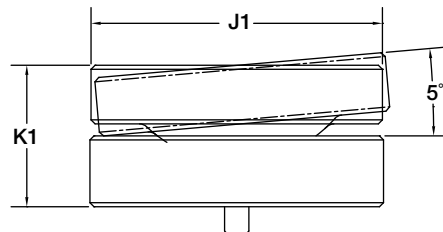

Figure 5, Dimensions, HCG-Series and HCR-Series

Refer to Figure 5 for dimensions A through K1

12.1 Dimensions, HCG-Series and HCR-Series (imperial)

Cylinder Model Number	Collapsed Height	Extended Height	Outside Diameter	Cyl. Bore Diameter	Plunger Diameter	Base to Advance Port	Top to * Retract Port	Std. Saddle Diameter	Saddle Protrusion from Plunger	Tilt Saddle (accessory)		
	A	B	D	E	F	H	I	J	K	Dia.	Height	Model No.
	in	in	in	in	in	in	in	in	in	in	in	
HCG/HCR-502	7.20	9.17	5.12	3.94	2.76	1.50	1.77	1.97	0.12	2.80	1.34	CATS-50
HCG/HCR-504	9.17	13.11	5.12	3.94	2.76	1.50	1.77	1.97	0.12	2.80	1.34	CATS-50
HCG/HCR-506	11.14	17.05	5.12	3.94	2.76	1.50	1.77	1.97	0.12	2.80	1.34	CATS-50
HCG/HCR-508	13.62	21.50	5.12	3.94	2.76	1.50	2.17	1.97	0.12	2.80	1.34	CATS-50
HCG/HCR-5010	15.59	25.43	5.12	3.94	2.76	1.50	2.17	1.97	0.12	2.80	1.34	CATS-50
HCG/HCR-5012	17.56	29.37	5.12	3.94	2.76	1.50	2.17	1.97	0.12	2.80	1.34	CATS-50
HCG/HCR-1002	7.95	9.92	6.89	5.31	3.74	1.50	2.56	2.95	0.12	2.80	1.18	CATS-101
HCG/HCR-1004	9.92	13.86	6.89	5.31	3.74	1.50	2.56	2.95	0.12	2.80	1.18	CATS-101
HCG/HCR-1006	11.89	17.80	6.89	5.31	3.74	1.50	2.56	2.95	0.12	2.80	1.18	CATS-101
HCG/HCR-1008	14.92	22.80	6.89	5.31	3.74	1.50	3.15	2.95	0.12	2.80	1.18	CATS-101
HCG/HCR-10010	16.89	26.73	6.89	5.31	3.74	1.50	3.15	2.95	0.12	2.80	1.18	CATS-101
HCG/HCR-10012	18.86	30.67	6.89	5.31	3.74	1.50	3.15	2.95	0.12	2.80	1.18	CATS-101
HCG/HCR-1502	8.66	10.63	8.46	6.50	4.72	1.61	2.76	3.70	0.12	3.82	1.54	CATS-150
HCG/HCR-1504	10.63	14.57	8.46	6.50	4.72	1.61	2.76	3.70	0.12	3.82	1.54	CATS-150
HCG/HCR-1506	12.60	18.50	8.46	6.50	4.72	1.61	2.76	3.70	0.12	3.82	1.54	CATS-150
HCG/HCR-1508	15.63	23.50	8.46	6.50	4.72	1.61	3.54	3.70	0.12	3.82	1.54	CATS-150
HCG/HCR-15010	17.60	27.44	8.46	6.50	4.72	1.61	3.54	3.70	0.12	3.82	1.54	CATS-150
HCG/HCR-15012	19.57	31.38	8.46	6.50	4.72	1.61	3.54	3.70	0.12	3.82	1.54	CATS-150
HCG/HCR-2002	9.09	11.06	9.84	7.48	5.51	1.85	3.11	4.45	0.12	4.96	1.69	CATS-200
HCG/HCR-2004	11.06	15.00	9.84	7.48	5.51	1.85	3.11	4.45	0.12	4.96	1.69	CATS-200
HCG/HCR-2006	13.03	18.94	9.84	7.48	5.51	1.85	3.11	4.45	0.12	4.96	1.69	CATS-200
HCG/HCR-2008	16.06	23.94	9.84	7.48	5.51	1.85	3.82	4.45	0.12	4.96	1.69	CATS-200
HCG/HCR-20010	18.03	27.87	9.84	7.48	5.51	1.85	3.82	4.45	0.12	4.96	1.69	CATS-200
HCG/HCR-20012	20.00	31.81	9.84	7.48	5.51	1.85	3.82	4.45	0.12	4.96	1.69	CATS-200
HCG/HCR-2502	9.49	11.46	11.02	8.46	6.69	2.09	3.11	5.49	0.16	6.89	2.70	CATS-300
HCG/HCR-2504	11.46	15.39	11.02	8.46	6.69	2.09	3.11	5.49	0.16	6.89	2.70	CATS-300
HCG/HCR-2506	13.43	19.33	11.02	8.46	6.69	2.09	3.11	5.49	0.16	6.89	2.70	CATS-300
HCG/HCR-2508	16.97	24.84	11.02	8.46	6.69	2.09	4.09	5.49	0.16	6.89	2.70	CATS-300
HCG/HCR-25010	18.94	28.78	11.02	8.46	6.69	2.09	4.09	5.49	0.16	6.89	2.70	CATS-300
HCG/HCR-25012	20.91	32.72	11.02	8.46	6.69	2.09	4.09	5.49	0.16	6.89	2.70	CATS-300
HCG/HCR-3002	11.65	13.62	12.01	9.25	7.87	2.28	3.98	5.49	0.16	6.89	2.70	CATS-300
HCG/HCR-3004	13.62	17.56	12.01	9.25	7.87	2.28	3.98	5.49	0.16	6.89	2.70	CATS-300
HCG/HCR-3006	15.59	21.50	12.01	9.25	7.87	2.28	3.98	5.49	0.16	6.89	2.70	CATS-300
HCG/HCR-3008	17.56	25.43	12.01	9.25	7.87	2.28	3.98	5.49	0.16	6.89	2.70	CATS-300
HCG/HCR-30010	19.53	29.37	12.01	9.25	7.87	2.28	3.98	5.49	0.16	6.89	2.70	CATS-300
HCG/HCR-30012	21.50	33.31	12.01	9.25	7.87	2.28	3.98	5.49	0.16	6.89	2.70	CATS-300
HCG/HCR-4002	12.64	14.61	13.78	10.63	8.66	2.91	4.37	6.27	0.16	8.27	3.07	CATS-400
HCG/HCR-4004	14.61	18.54	13.78	10.63	8.66	2.91	4.37	6.27	0.16	8.27	3.07	CATS-400
HCG/HCR-4006	16.57	22.48	13.78	10.63	8.66	2.91	4.37	6.27	0.16	8.27	3.07	CATS-400
HCG/HCR-4008	18.54	26.42	13.78	10.63	8.66	2.91	4.37	6.27	0.16	8.27	3.07	CATS-400
HCG/HCR-40010	20.51	30.35	13.78	10.63	8.66	2.91	4.37	6.27	0.16	8.27	3.07	CATS-400
HCG/HCR-40012	22.48	34.29	13.78	10.63	8.66	2.91	4.37	6.27	0.16	8.27	3.07	CATS-400
HCG/HCR-5002	13.54	15.51	15.75	12.01	9.84	3.11	4.76	7.06	0.16	9.06	3.07	CATS-500
HCG/HCR-5004	15.51	19.45	15.75	12.01	9.84	3.11	4.76	7.06	0.16	9.06	3.07	CATS-500
HCG/HCR-5006	17.48	23.39	15.75	12.01	9.84	3.11	4.76	7.06	0.16	9.06	3.07	CATS-500
HCG/HCR-5008	19.45	27.32	15.75	12.01	9.84	3.11	4.76	7.06	0.16	9.06	3.07	CATS-500
HCG/HCR-50010	21.42	31.26	15.75	12.01	9.84	3.11	4.76	7.06	0.16	9.06	3.07	CATS-500
HCG/HCR-50012	23.39	35.20	15.75	12.01	9.84	3.11	4.76	7.06	0.16	9.06	3.07	CATS-500
HCG/HCR-6002	13.86	15.83	16.93	12.99	10.63	3.35	4.76	7.65	0.16	9.84	3.27	CATS-600
HCG/HCR-6004	15.83	19.76	16.93	12.99	10.63	3.35	4.76	7.65	0.16	9.84	3.27	CATS-600
HCG/HCR-6006	17.80	23.70	16.93	12.99	10.63	3.35	4.76	7.65	0.16	9.84	3.27	CATS-600
HCG/HCR-6008	19.76	27.64	16.93	12.99	10.63	3.35	4.76	7.65	0.16	9.84	3.27	CATS-600
HCG/HCR-60010	21.73	31.57	16.93	12.99	10.63	3.35	4.76	7.65	0.16	9.84	3.27	CATS-600
HCG/HCR-60012	23.70	35.51	16.93	12.99	10.63	3.35	4.76	7.65	0.16	9.84	3.27	CATS-600
HCG/HCR-8002	15.91	17.87	19.88	15.16	12.60	3.94	5.63	8.83	0.16	10.83	3.41	CATS-800
HCG/HCR-8004	17.87	21.81	19.88	15.16	12.60	3.94	5.63	8.83	0.16	10.83	3.41	CATS-800
HCG/HCR-8006	19.84	25.75	19.88	15.16	12.60	3.94	5.63	8.83	0.16	10.83	3.41	CATS-800
HCG/HCR-8008	21.81	29.69	19.88	15.16	12.60	3.94	5.63	8.83	0.16	10.83	3.41	CATS-800
HCG/HCR-80010	23.78	33.62	19.88	15.16	12.60	3.94	5.63	8.83	0.16	10.83	3.41	CATS-800
HCG/HCR-80012	25.75	37.56	19.88	15.16	12.60	3.94	5.63	8.83	0.16	10.83	3.41	CATS-800
HCG/HCR-10002	17.40	19.37	22.44	17.32	13.39	4.49	6.02	9.81	0.16	11.81	4.22	CATS-1000
HCG/HCR-10004	19.37	23.31	22.44	17.32	13.39	4.49	6.02	9.81	0.16	11.81	4.22	CATS-1000
HCG/HCR-10006	21.34	27.24	22.44	17.32	13.39	4.49	6.02	9.81	0.16	11.81	4.22	CATS-1000
HCG/HCR-10008	23.31	31.18	22.44	17.32	13.39	4.49	6.02	9.81	0.16	11.81	4.22	CATS-1000
HCG/HCR-100010	25.28	35.12	22.44	17.32	13.39	4.49	6.02	9.81	0.16	11.81	4.22	CATS-1000
HCG/HCR-100012	27.24	39.06	22.44	17.32	13.39	4.49	6.02	9.81	0.16	11.81	4.22	CATS-1000

* Dimension "I" is applicable to HCR Models only.

Refer to Figure 5 for dimensions A through K1

12.2 Dimensions, HCG-Series and HCR-Series (metric)

Cylinder Model Number	Collapsed Height	Extended Height	Outside Diameter	Cyl. Bore Diameter	Plunger Diameter	Base to Advance Port	Top to * Retract Port	Std. Saddle Diameter	Saddle Protrusion from Plunger	Tilt Saddle (accessory)		
	A	B	D	E	F	H	I	J	K	Dia.	Height	Model No.
	mm	mm	mm	mm	mm	mm	mm	mm	mm	mm	mm	
HCG/HCR-502	183	233	130	100	70	38	45	50	3	71	34	CATS-50
HCG/HCR-504	233	333	130	100	70	38	45	50	3	71	34	CATS-50
HCG/HCR-506	283	433	130	100	70	38	45	50	3	71	34	CATS-50
HCG/HCR-508	346	546	130	100	70	38	55	50	3	71	34	CATS-50
HCG/HCR-5010	396	646	130	100	70	38	55	50	3	71	34	CATS-50
HCG/HCR-5012	446	746	130	100	70	38	55	50	3	71	34	CATS-50
HCG/HCR-1002	202	252	175	135	95	38	65	75	3	71	30	CATS-101
HCG/HCR-1004	252	352	175	135	95	38	65	75	3	71	30	CATS-101
HCG/HCR-1006	302	452	175	135	95	38	65	75	3	71	30	CATS-101
HCG/HCR-1008	379	579	175	135	95	38	80	75	3	71	30	CATS-101
HCG/HCR-10010	429	679	175	135	95	38	80	75	3	71	30	CATS-101
HCG/HCR-10012	479	779	175	135	95	38	80	75	3	71	30	CATS-101
HCG/HCR-1502	220	270	215	165	120	41	70	94	3	97	39	CATS-150
HCG/HCR-1504	270	370	215	165	120	41	70	94	3	97	39	CATS-150
HCG/HCR-1506	320	470	215	165	120	41	70	94	3	97	39	CATS-150
HCG/HCR-1508	397	597	215	165	120	41	90	94	3	97	39	CATS-150
HCG/HCR-15010	447	697	215	165	120	41	90	94	3	97	39	CATS-150
HCG/HCR-15012	497	797	215	165	120	41	90	94	3	97	39	CATS-150
HCG/HCR-2002	231	281	250	190	140	47	79	113	3	126	43	CATS-200
HCG/HCR-2004	281	381	250	190	140	47	79	113	3	126	43	CATS-200
HCG/HCR-2006	331	481	250	190	140	47	79	113	3	126	43	CATS-200
HCG/HCR-2008	408	608	250	190	140	47	97	113	3	126	43	CATS-200
HCG/HCR-20010	458	708	250	190	140	47	97	113	3	126	43	CATS-200
HCG/HCR-20012	508	808	250	190	140	47	97	113	3	126	43	CATS-200
HCG/HCR-2502	241	291	280	215	170	53	79	140	4	175	69	CATS-300
HCG/HCR-2504	291	391	280	215	170	53	79	140	4	175	69	CATS-300
HCG/HCR-2506	341	491	280	215	170	53	79	140	4	175	69	CATS-300
HCG/HCR-2508	431	631	280	215	170	53	104	140	4	175	69	CATS-300
HCG/HCR-25010	481	731	280	215	170	53	104	140	4	175	69	CATS-300
HCG/HCR-25012	531	831	280	215	170	53	104	140	4	175	69	CATS-300
HCG/HCR-3002	296	346	305	235	200	58	101	140	4	175	69	CATS-300
HCG/HCR-3004	346	446	305	235	200	58	101	140	4	175	69	CATS-300
HCG/HCR-3006	396	546	305	235	200	58	101	140	4	175	69	CATS-300
HCG/HCR-3008	446	646	305	235	200	58	101	140	4	175	69	CATS-300
HCG/HCR-30010	496	746	305	235	200	58	101	140	4	175	69	CATS-300
HCG/HCR-30012	546	846	305	235	200	58	101	140	4	175	69	CATS-300
HCG/HCR-4002	321	371	350	270	220	74	111	159	4	210	78	CATS-400
HCG/HCR-4004	371	471	350	270	220	74	111	159	4	210	78	CATS-400
HCG/HCR-4006	421	571	350	270	220	74	111	159	4	210	78	CATS-400
HCG/HCR-4008	471	671	350	270	220	74	111	159	4	210	78	CATS-400
HCG/HCR-40010	521	771	350	270	220	74	111	159	4	210	78	CATS-400
HCG/HCR-40012	571	871	350	270	220	74	111	159	4	210	78	CATS-400
HCG/HCR-5002	344	394	400	305	250	79	121	179	4	230	78	CATS-500
HCG/HCR-5004	394	494	400	305	250	79	121	179	4	230	78	CATS-500
HCG/HCR-5006	444	594	400	305	250	79	121	179	4	230	78	CATS-500
HCG/HCR-5008	494	694	400	305	250	79	121	179	4	230	78	CATS-500
HCG/HCR-50010	544	794	400	305	250	79	121	179	4	230	78	CATS-500
HCG/HCR-50012	594	894	400	305	250	79	121	179	4	230	78	CATS-500
HCG/HCR-6002	352	402	430	330	270	85	121	194	4	250	83	CATS-600
HCG/HCR-6004	402	502	430	330	270	85	121	194	4	250	83	CATS-600
HCG/HCR-6006	452	602	430	330	270	85	121	194	4	250	83	CATS-600
HCG/HCR-6008	502	702	430	330	270	85	121	194	4	250	83	CATS-600
HCG/HCR-60010	552	802	430	330	270	85	121	194	4	250	83	CATS-600
HCG/HCR-60012	602	902	430	330	270	85	121	194	4	250	83	CATS-600
HCG/HCR-8002	404	454	505	385	320	100	143	224	4	275	87	CATS-800
HCG/HCR-8004	454	554	505	385	320	100	143	224	4	275	87	CATS-800
HCG/HCR-8006	504	654	505	385	320	100	143	224	4	275	87	CATS-800
HCG/HCR-8008	554	754	505	385	320	100	143	224	4	275	87	CATS-800
HCG/HCR-80010	604	854	505	385	320	100	143	224	4	275	87	CATS-800
HCG/HCR-80012	654	954	505	385	320	100	143	224	4	275	87	CATS-800
HCG/HCR-10002	442	492	570	440	340	114	153	249	4	300	107	CATS-1000
HCG/HCR-10004	492	592	570	440	340	114	153	249	4	300	107	CATS-1000
HCG/HCR-10006	542	692	570	440	340	114	153	249	4	300	107	CATS-1000
HCG/HCR-10008	592	792	570	440	340	114	153	249	4	300	107	CATS-1000
HCG/HCR-100010	642	892	570	440	340	114	153	249	4	300	107	CATS-1000
HCG/HCR-100012	692	992	570	440	340	114	153	249	4	300	107	CATS-1000

* Dimension "I" is applicable to HCR Models only.

12.3 Base Mounting Holes and Collar Threads, HCG-Series and HCR-Series

Cylinder Model Number	Base Mounting Holes							Collar Threads		
	Bolt Circle		Thread Size	Minimum Thread Depth		Number of Holes	Angle From Coupler	Thread Size	Thread Length	
	U		V	Z				W	X	
	in	mm	mm	in	mm			mm	in	mm
HCG/HCR-502	4.13	105	M12 x 1.75	0.87	22	2	90°	M130 x 2	0.79	20
HCG/HCR-504	4.13	105	M12 x 1.75	0.87	22	2	90°	M130 x 2	0.79	20
HCG/HCR-506	4.13	105	M12 x 1.75	0.87	22	2	90°	M130 x 2	0.79	20
HCG/HCR-508	4.13	105	M12 x 1.75	0.87	22	2	90°	M130 x 2	0.79	20
HCG/HCR-5010	4.13	105	M12 x 1.75	0.87	22	2	90°	M130 x 2	0.79	20
HCG/HCR-5012	4.13	105	M12 x 1.75	0.87	22	2	90°	M130 x 2	0.79	20
HCG/HCR-1002	5.91	150	M12 x 1.75	0.87	22	2	90°	M175 x 3	1.57	40
HCG/HCR-1004	5.91	150	M12 x 1.75	0.87	22	2	90°	M175 x 3	1.57	40
HCG/HCR-1006	5.91	150	M12 x 1.75	0.87	22	2	90°	M175 x 3	1.57	40
HCG/HCR-1008	5.91	150	M12 x 1.75	0.87	22	2	90°	M175 x 3	1.57	40
HCG/HCR-10010	5.91	150	M12 x 1.75	0.87	22	2	90°	M175 x 3	1.57	40
HCG/HCR-10012	5.91	150	M12 x 1.75	0.87	22	2	90°	M175 x 3	1.57	40
HCG/HCR-1502	7.28	185	M12 x 1.75	0.87	22	2	90°	M215 x 3	1.85	47
HCG/HCR-1504	7.28	185	M12 x 1.75	0.87	22	2	90°	M215 x 3	1.85	47
HCG/HCR-1506	7.28	185	M12 x 1.75	0.87	22	2	90°	M215 x 3	1.85	47
HCG/HCR-1508	7.28	185	M12 x 1.75	0.87	22	2	90°	M215 x 3	1.85	47
HCG/HCR-15010	7.28	185	M12 x 1.75	0.87	22	2	90°	M215 x 3	1.85	47
HCG/HCR-15012	7.28	185	M12 x 1.75	0.87	22	2	90°	M215 x 3	1.85	47
HCG/HCR-2002	8.46	215	M12 x 1.75	0.87	22	3	60°	M250 x 3	2.17	55
HCG/HCR-2004	8.46	215	M12 x 1.75	0.87	22	3	60°	M250 x 3	2.17	55
HCG/HCR-2006	8.46	215	M12 x 1.75	0.87	22	3	60°	M250 x 3	2.17	55
HCG/HCR-2008	8.46	215	M12 x 1.75	0.87	22	3	60°	M250 x 3	2.17	55
HCG/HCR-20010	8.46	215	M12 x 1.75	0.87	22	3	60°	M247 x 3	2.17	55
HCG/HCR-20012	8.46	215	M12 x 1.75	0.87	22	3	60°	M247 x 3	2.17	55
HCG/HCR-2502	9.65	245	M12 x 1.75	0.87	22	3	60°	M280 x 3	2.44	62
HCG/HCR-2504	9.65	245	M12 x 1.75	0.87	22	3	60°	M280 x 3	2.44	62
HCG/HCR-2506	9.65	245	M12 x 1.75	0.87	22	3	60°	M280 x 3	2.44	62
HCG/HCR-2508	9.65	245	M12 x 1.75	0.87	22	3	60°	M280 x 3	2.44	62
HCG/HCR-25010	9.65	245	M12 x 1.75	0.87	22	3	60°	M280 x 3	2.44	62
HCG/HCR-25012	9.65	245	M12 x 1.75	0.87	22	3	60°	M280 x 3	2.44	62
HCG/HCR-3002	10.24	260	M16 x 2	0.98	25	3	60°	M305 x 3	2.36	60
HCG/HCR-3004	10.24	260	M16 x 2	0.98	25	3	60°	M305 x 3	2.36	60
HCG/HCR-3006	10.24	260	M16 x 2	0.98	25	3	60°	M305 x 3	2.36	60
HCG/HCR-3008	10.24	260	M16 x 2	0.98	25	3	60°	M305 x 3	2.36	60
HCG/HCR-30010	10.24	260	M16 x 2	0.98	25	3	60°	M305 x 3	2.36	60
HCG/HCR-30012	10.24	260	M16 x 2	0.98	25	3	60°	M305 x 3	2.36	60
HCG/HCR-4002	11.81	300	M16 x 2	0.98	25	3	60°	M350 x 3	2.95	75
HCG/HCR-4004	11.81	300	M16 x 2	0.98	25	3	60°	M350 x 3	2.95	75
HCG/HCR-4006	11.81	300	M16 x 2	0.98	25	3	60°	M350 x 3	2.95	75
HCG/HCR-4008	11.81	300	M16 x 2	0.98	25	3	60°	M350 x 3	2.95	75
HCG/HCR-40010	11.81	300	M16 x 2	0.98	25	3	60°	M350 x 3	2.95	75
HCG/HCR-40012	11.81	300	M16 x 2	0.98	25	3	60°	M350 x 3	2.95	75
HCG/HCR-5002	13.39	340	M24 x 3	1.42	36	3	60°	M400 x 3	3.15	80
HCG/HCR-5004	13.39	340	M24 x 3	1.42	36	3	60°	M400 x 3	3.15	80
HCG/HCR-5006	13.39	340	M24 x 3	1.42	36	3	60°	M400 x 3	3.15	80
HCG/HCR-5008	13.39	340	M24 x 3	1.42	36	3	60°	M400 x 3	3.15	80
HCG/HCR-50010	13.39	340	M24 x 3	1.42	36	3	60°	M400 x 3	3.15	80
HCG/HCR-50012	13.39	340	M24 x 3	1.42	36	3	60°	M400 x 3	3.15	80
HCG/HCR-6002	14.57	370	M24 x 3	1.42	36	3	60°	M430 x 3	3.54	90
HCG/HCR-6004	14.57	370	M24 x 3	1.42	36	3	60°	M430 x 3	3.54	90
HCG/HCR-6006	14.57	370	M24 x 3	1.42	36	3	60°	M430 x 3	3.54	90
HCG/HCR-6008	14.57	370	M24 x 3	1.42	36	3	60°	M430 x 3	3.54	90
HCG/HCR-60010	14.57	370	M24 x 3	1.42	36	3	60°	M430 x 3	3.54	90
HCG/HCR-60012	14.57	370	M24 x 3	1.42	36	3	60°	M430 x 3	3.54	90
HCG/HCR-8002	17.32	440	M24 x 3	1.42	36	3	60°	M505 x 3	4.33	110
HCG/HCR-8004	17.32	440	M24 x 3	1.42	36	3	60°	M505 x 3	4.33	110
HCG/HCR-8006	17.32	440	M24 x 3	1.42	36	3	60°	M505 x 3	4.33	110
HCG/HCR-8008	17.32	440	M24 x 3	1.42	36	3	60°	M505 x 3	4.33	110
HCG/HCR-80010	17.32	440	M24 x 3	1.42	36	3	60°	M505 x 3	4.33	110
HCG/HCR-80012	17.32	440	M24 x 3	1.42	36	3	60°	M505 x 3	4.33	110
HCG/HCR-10002	19.69	500	M24 x 3	1.42	36	3	60°	M570 x 3	4.92	125
HCG/HCR-10004	19.69	500	M24 x 3	1.42	36	3	60°	M570 x 3	4.92	125
HCG/HCR-10006	19.69	500	M24 x 3	1.42	36	3	60°	M570 x 3	4.92	125
HCG/HCR-10008	19.69	500	M24 x 3	1.42	36	3	60°	M570 x 3	4.92	125
HCG/HCR-100010	19.69	500	M24 x 3	1.42	36	3	60°	M570 x 3	4.92	125
HCG/HCR-100012	19.69	500	M24 x 3	1.42	36	3	60°	M570 x 3	4.92	125

12.4 Specifications, HCG-Series and HCR-Series

Cylinder Model Number	Stroke		Cylinder Class	Maximum Capacity			Effective Area		Oil Capacity		Weight *	
	in	mm		US Ton	Tonnes	kN	in ²	cm ²	in ³	cm ³	lb	Kg
HCG/HCR-502	1.97	50	50	62	56	550	12.17	78.5	23.96	393	37	17
HCG/HCR-504	3.94	100	50	62	56	550	12.17	78.5	47.93	785	46	21
HCG/HCR-506	5.91	150	50	62	56	550	12.17	78.5	71.89	1178	54	25
HCG/HCR-508	7.87	200	50	62	56	550	12.17	78.5	95.86	1571	68	31
HCG/HCR-5010	9.84	250	50	62	56	550	12.17	78.5	119.82	1963	76	34
HCG/HCR-5012	11.81	300	50	62	56	550	12.17	78.5	143.78	2356	84	38
HCG/HCR-1002	1.97	50	100	113	102	1002	22.19	143.1	43.67	716	74	34
HCG/HCR-1004	3.94	100	100	113	102	1002	22.19	143.1	87.35	1431	90	41
HCG/HCR-1006	5.91	150	100	113	102	1002	22.19	143.1	131.02	2147	105	48
HCG/HCR-1008	7.87	200	100	113	102	1002	22.19	143.1	174.70	2863	131	59
HCG/HCR-10010	9.84	250	100	113	102	1002	22.19	143.1	218.37	3578	146	66
HCG/HCR-10012	11.81	300	100	113	102	1002	22.19	143.1	262.05	4294	161	73
HCG/HCR-1502	1.97	50	150	168	153	1497	33.14	213.8	65.24	1069	124	56
HCG/HCR-1504	3.94	100	150	168	153	1497	33.14	213.8	130.48	2138	148	67
HCG/HCR-1506	5.91	150	150	168	153	1497	33.14	213.8	195.73	3207	172	78
HCG/HCR-1508	7.87	200	150	168	153	1497	33.14	213.8	260.97	4276	209	95
HCG/HCR-15010	9.84	250	150	168	153	1497	33.14	213.8	326.21	5346	233	106
HCG/HCR-15012	11.81	300	150	168	153	1497	33.14	213.8	391.45	6415	257	116
HCG/HCR-2002	1.97	50	200	223	202	1985	43.95	283.5	86.51	1418	179	81
HCG/HCR-2004	3.94	100	200	223	202	1985	43.95	283.5	173.02	2835	212	96
HCG/HCR-2006	5.91	150	200	223	202	1985	43.95	283.5	259.53	4253	244	111
HCG/HCR-2008	7.87	200	200	223	202	1985	43.95	283.5	346.04	5671	306	139
HCG/HCR-20010	9.84	250	200	223	202	1985	43.95	283.5	432.55	7088	338	153
HCG/HCR-20012	11.81	300	200	223	202	1985	43.95	283.5	519.06	8506	371	168
HCG/HCR-2502	1.97	50	250	286	259	2541	56.27	363.1	110.77	1815	236	107
HCG/HCR-2504	3.94	100	250	286	259	2541	56.27	363.1	221.55	3631	279	127
HCG/HCR-2506	5.91	150	250	286	259	2541	56.27	363.1	332.32	5446	322	146
HCG/HCR-2508	7.87	200	250	286	259	2541	56.27	363.1	443.09	7261	407	184
HCG/HCR-25010	9.84	250	250	286	259	2541	56.27	363.1	553.87	9076	457	207
HCG/HCR-25012	11.81	300	250	286	259	2541	56.27	363.1	664.64	10892	500	227
HCG/HCR-3002	1.97	50	300	341	310	3036	67.23	433.7	132.34	2169	350	159
HCG/HCR-3004	3.94	100	300	341	310	3036	67.23	433.7	264.68	4337	404	183
HCG/HCR-3006	5.91	150	300	341	310	3036	67.23	433.7	397.02	6506	458	208
HCG/HCR-3008	7.87	200	300	341	310	3036	67.23	433.7	529.36	8675	512	232
HCG/HCR-30010	9.84	250	300	341	310	3036	67.23	433.7	661.71	10843	566	257
HCG/HCR-30012	11.81	300	300	341	310	3036	67.23	433.7	794.05	13012	620	281
HCG/HCR-4002	1.97	50	400	450	409	4008	88.75	572.6	174.70	2863	501	227
HCG/HCR-4004	3.94	100	400	450	409	4008	88.75	572.6	349.39	5726	570	258
HCG/HCR-4006	5.91	150	400	450	409	4008	88.75	572.6	524.09	8588	638	289
HCG/HCR-4008	7.87	200	400	450	409	4008	88.75	572.6	698.79	11451	707	321
HCG/HCR-40010	9.84	250	400	450	409	4008	88.75	572.6	873.49	14314	775	352
HCG/HCR-40012	11.81	300	400	450	409	4008	88.75	572.6	1,048.18	17177	843	383
HCG/HCR-5002	1.97	50	500	575	522	5114	113.25	730.6	222.92	3653	706	320
HCG/HCR-5004	3.94	100	500	575	522	5114	113.25	730.6	445.85	7306	797	361
HCG/HCR-5006	5.91	150	500	575	522	5114	113.25	730.6	668.77	10959	887	402
HCG/HCR-5008	7.87	200	500	575	522	5114	113.25	730.6	891.70	14612	977	443
HCG/HCR-50010	9.84	250	500	575	522	5114	113.25	730.6	1114.62	18265	1067	484
HCG/HCR-50012	11.81	300	500	575	522	5114	113.25	730.6	1337.55	21918	1158	525
HCG/HCR-6002	1.97	50	600	673	611	5987	132.57	855.3	260.97	4276	836	379
HCG/HCR-6004	3.94	100	600	673	611	5987	132.57	855.3	521.94	8553	940	427
HCG/HCR-6006	5.91	150	600	673	611	5987	132.57	855.3	782.90	12829	1044	474
HCG/HCR-6008	7.87	200	600	673	611	5987	132.57	855.3	1043.87	17106	1148	521
HCG/HCR-60010	9.84	250	600	673	611	5987	132.57	855.3	1304.84	21382	1252	568
HCG/HCR-60012	11.81	300	600	673	611	5987	132.57	855.3	1565.81	25659	1356	615
HCG/HCR-8002	1.97	50	800	916	831	8149	180.44	1164.2	355.21	5821	1340	608
HCG/HCR-8004	3.94	100	800	916	831	8149	180.44	1164.2	710.41	11642	1485	674
HCG/HCR-8006	5.91	150	800	916	831	8149	180.44	1164.2	1065.62	17462	1631	740
HCG/HCR-8008	7.87	200	800	916	831	8149	180.44	1164.2	1420.82	23283	1777	806
HCG/HCR-80010	9.84	250	800	916	831	8149	180.44	1164.2	1776.03	29104	1922	872
HCG/HCR-80012	11.81	300	800	916	831	8149	180.44	1164.2	2131.24	34925	2068	938
HCG/HCR-10002	1.97	50	1000	1196	1085	10644	235.68	1520.5	463.94	7603	1858	843
HCG/HCR-10004	3.94	100	1000	1196	1085	10644	235.68	1520.5	927.88	15205	2031	921
HCG/HCR-10006	5.91	150	1000	1196	1085	10644	235.68	1520.5	1391.83	22808	2205	1000
HCG/HCR-10008	7.87	200	1000	1196	1085	10644	235.68	1520.5	1855.77	30411	2379	1079
HCG/HCR-100010	9.84	250	1000	1196	1085	10644	235.68	1520.5	2319.71	38013	2552	1158
HCG/HCR-100012	11.81	300	1000	1196	1085	10644	235.68	1520.5	2783.65	45616	2726	1236

* Weights for HCR-Series shown. Weights for HCG-Series are slightly less.

