

HV-1000A HOLDING VALVE

L-1666 Rev. 0 1/99

For Date Codes Beginning with the Letter "O"

1.0 IMPORTANT RECEIVING INSTRUCTIONS

Visually inspect all components for shipping damage. Shipping damage is **not** covered by warranty. If shipping damage is found, notify carrier at once. The carrier is responsible for all repair and replacement costs resulting from damage in shipment.

SAFETY FIRST

2.0 SAFETY ISSUES



Read all instructions, warnings, and cautions carefully. Follow all safety precautions to avoid personal injury or property damage during system operation. Enerpac cannot be responsible for damage or injury resulting from unsafe product use, lack of maintenance or incorrect product and/or system operation. Contact Enerpac when in doubt as to the safety precautions and operations. If you have never been trained on high-pressure hydraulic safety, consult your distribution or service center for a free Enerpac Hydraulic safety course.

Failure to comply with the following cautions and warnings could cause equipment damage and personal injury.

A **CAUTION** is used to indicate correct operating or maintenance procedures and practices to prevent damage to, or destruction of equipment or other property.

A **WARNING** indicates a potential danger that requires correct procedures or practices to avoid personal injury.

A **DANGER** is only used when your action or lack of action may cause serious injury or even death.



WARNING: Wear proper personal protective gear when operating hydraulic equipment.



WARNING: Stay clear of loads supported by hydraulics. A cylinder, when used as a load lifting device, should never be used as a load holding device. After the load has been raised or lowered, it must always be blocked mechanically.



WARNING: USE ONLY RIGID PIECES TO HOLD LOADS. Carefully select steel or wood blocks that are capable of supporting the load. Never use a hydraulic cylinder as a shim or spacer in any lifting or pressing application.



DANGER: To avoid personal injury keep hands and feet away from cylinder and workpiece during operation.



WARNING: Do not exceed equipment ratings. Never attempt to lift a load weighing more than the capacity of the cylinder. Overloading causes equipment failure and possible personal injury. The cylinders are designed for a max. pressure of 700 bar. Do not connect a jack or cylinder to a pump with a higher pressure rating.



Never set the relief valve to a higher pressure than the maximum rated pressure of the pump. Higher settings may result in equipment damage and/or personal injury.



WARNING: The system operating pressure must not exceed the pressure rating of the lowest rated component in the system. Install pressure gauges in the system to monitor operating pressure. It is your window to what is happening in the system.



CAUTION: Avoid damaging hydraulic hose. Avoid sharp bends and kinks when routing hydraulic hoses. Using a bent or kinked hose will cause severe back-pressure. Sharp bends and kinks will internally damage the hose leading to premature hose failure.



Do not drop heavy objects on hose. A sharp impact may cause internal damage to hose wire strands. Applying pressure to a damaged hose may cause it to rupture.



IMPORTANT: Do not lift hydraulic equipment by the hoses or swivel couplers. Use the carrying handle or other means of safe transport.



CAUTION: Keep hydraulic equipment away from flames and heat. Excessive heat will soften packings and seals, resulting in fluid leaks. Heat also weakens hose materials and packings. For optimum performance **do not** expose equipment to temperatures of 65°C [150°F] or higher. Protect hoses and cylinders from weld spatter.



DANGER: Do not handle pressurized hoses. Escaping oil under pressure can penetrate the skin, causing serious injury. If oil is injected under the skin, see a doctor immediately.



WARNING: Only use hydraulic cylinders in a coupled system. Never use a cylinder with unconnected couplers. If the cylinder becomes extremely overloaded, components can fail catastrophically causing severe personal injury.



WARNING: BE SURE SETUP IS STABLE BEFORE LIFTING LOAD.

Cylinders should be placed on a flat surface that can support the load. Where applicable, use a cylinder base for added stability. Do not weld or otherwise modify the cylinder to attach a base or other support.



Avoid situations where loads are not directly centered on the cylinder plunger. Off-center loads produce considerable strain on cylinders and plungers. In addition, the load may slip or fall, causing potentially dangerous results.



Distribute the load evenly across the entire saddle surface. Always use a saddle to protect the plunger.



IMPORTANT: Hydraulic equipment must only be serviced by a qualified hydraulic technician. For repair service, contact the Authorized ENERPAC Service Center in your area. To protect your warranty, use only ENERPAC oil.



WARNING: Immediately replace worn or damaged parts by genuine ENERPAC parts. Standard grade parts will break causing personal injury and property damage. ENERPAC parts are designed to fit properly and withstand high loads.

3.0 DESCRIPTION

This air pilot holding valve will hold fluid under pressure offering independent control of different branches of the same fixture. Valve works with the VA-42 4-way air valve and a booster. Valve can control the pilot air and the booster in sequence.

SPECIFICATIONS

Maximum Hydraulic Pressure3,000 psi
Working Air Pressure Range14 psi air @ 1,000 psi hydraulic
Seal MaterialBuna-N

4.0 INSTALLATION

1. The unit can be mounted in any direction. Secure the valve to a flat surface with two 1/4" mounting bolts.
2. Connect the pressure line from your pressure source to the hydraulic inlet port.
3. Connect another line from the hydraulic outlet port at the end of the valve to your cylinder or tool.
4. Connect an air line from a directional air valve to the air inlet.

5.0 OPERATION

1. Ensure that the directional air valve is positioned so that there is no air pressure going to air pilot port on HV1000A.
2. Operate pressure source. HV1000A should allow system to build hydraulic pressure without leaks.
3. To release hydraulic pressure, apply air pressure to air inlet by switching air directional valve. Pilot ratio is approximately 70 to 1.
4. To begin cycle again, release air pressure from air inlet. Activate pressure source again.

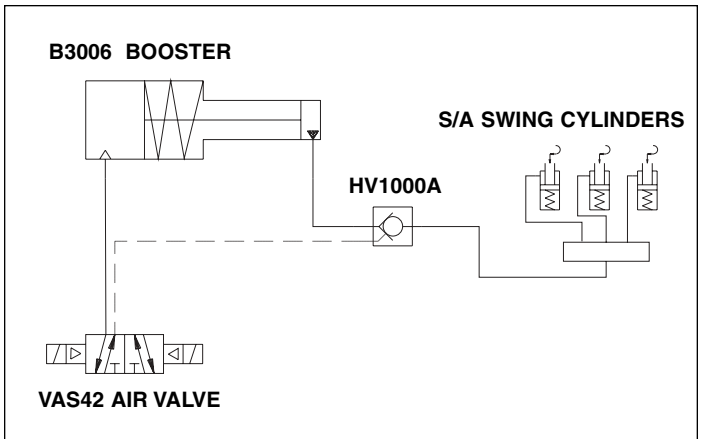

Figure 1. Example Circuit

TROUBLESHOOTING

SYMPTOM	POSSIBLE CAUSE	SOLUTION
Valve does not hold hydraulic pressure.	External leak.	Check all hydraulic fittings.
	Contamination in valve.	Flush hydraulic section of valve with clean oil. If this does not work, consult service center.
	Air pressure getting to air inlet.	Check air valve for leaks and proper operation.
Valve does not release pressure.	Contamination in valve.	Flush hydraulic section of valve with clean oil. If this does not work, consult service center.
	Air pressure too low.	Check regulator setting.
	Possible air leak.	Check all air connections.

Australia

ENERPAC, Applied Power Australia Ltd.
Block V Unit 3,
Regents Park Estate,
391 Park Road
Regents Park NSW 2143
(P.O. Box 261) Australia
Tel: +61 297 438 988
Fax: +61 297 438 648

Brazil

Power Packer do
Brasil LTDA
Avenida Ferraz
Alvim n° 1012
(09961-550) - Diadema
S°o Paulo, Brazil
Tel: +55 11 4051 1188
Fax: +55 11 4051 3699

China

Shanghai Blackhawk
Machinery Co Ltd
15H Jinxuan Building
238 Nandan Road (E)
Shanghai, 200030, China
Tel: +86 21 6469 8732
Fax: +86 21 6469 8721

**France, Greece, Turkey, Middle East,
Africa**

ENERPAC S.A.
B.P. 200, Parc d ActivitØs
du Moulin de Massy
F-91882 Massy CEDEX (Paris) France
Tel: +33 01 601 368 68
Fax: +33 01 692 037 50

Germany, Denmark, Scandinavia,**Austria, Switzerland, Eastern****Europe, CIS**

ENERPAC
Applied Power GmbH
P.O. Box 300113
D-40401 D sseldorf, Germany
Tel: +49 211 471 490
Fax: +49 211 471 49 28/40

Holland, Belgium, Luxembourg,

ENERPAC B.V.
Storkstraat 25
P.O. Box 269
3900 AG Veenendaal, Holland
Tel: +31 318 535 911
Fax: +31 318 535 848
+31 318 526 645

Hong Kong

ENERPAC
Room 907 Workingberg
Commercial Building
41-47 Marble Road,
North Point
Tel: +852-2561 6295
Fax: +852-2561 6772

India

ENERPAC
Hydraulic (India) Pvt Ltd
Plot No. A-571
MIDC, TTC Industrial Area
Mahape-400 701,
Navi Mumbai, India
Tel: +91 22 769 47 78
Fax: +91 22 769 84 73

Italy

ENERPAC Applied Power Italiana S.p.A.
Via Canova 4,
20094 Corsico (Milano)
Tel: +39 2 486 111 00
Fax: +39 2 486 012 88

Japan

Applied Power Japan Ltd.
10-17 Sasame Kita-Machi
Toda-Shi, Saitama #335, Japan
Tel: +81 048 421 2311
Fax: +81 048 421 8949

Malaysia

Applied Power Hytec (M) Sdn Bhd 22-1,
Jalan SS 15/8B
Subang Jaya, 47500
P.J. Selangor
West Malaysia
Tel: (0203) 73729 23/39/19
Fax: (0203) 737 29 18

Mexico

ENERPAC Applied Power Mexico S.A. de
C.V.
Avenida Principal,
La Paz #100
Fracc. Industrial La Paz
42084 Pachuca, Hidalgo
Tel: +52 771 337 00
Fax: +52 771 838 00

Singapore

Applied Power Asia Pte Ltd
47 Jalan Pemimpin,
#01-02 & 01-03
Sin Cheong Bldg
Singapore 577200
Thomson Road,
P.O. Box 114
Singapore 915704
Tel: +65 258 16 77
Fax: +65 258 28 47

South Korea

ENERPAC
Applied Power Korea Ltd.
163-12 Dodang-Dong, Choong-Ku,
Buchun-shi, Kyunggi-Do
Republic of Korea
Tel: +82 32 675 08 36
Fax: +82 32 675 30 02

Spain, Portugal

ENERPAC Applied Power International S.A.
A. Valgrande 14
Nave 12
28108 Alcobendas (Madrid), Spain
Tel: +34 91 661 11 25
Fax: +34 91 661 47 89

United Kingdom, Ireland

ENERPAC Limited
Unit 3 Colemeadow Road
North Moons Moat, Redditch
Worcester B98 9PB
United Kingdom
Tel: +44 01527 598 900
Fax: +44 01527 585 500

**USA, Canada, Latin America and
Caribbean**

ENERPAC
6101 N. Baker Road
Milwaukee, WI 53209 USA
Tel: +1 414 781 66 00
Fax: +1 414 781 10 49

USA

User inquiries:
+1 800 433 2766
Distributor inquiries/orders:
+1 800 558 0530

Canada

User inquiries:
+1 800 426 4129
Distributor inquiries/orders:
+1 800 426 2284

Internet

www.enerpac.com

e-mail

info@enerpac.com

**All Enerpac products are guaranteed against defects in workmanship and materials for as long as you own them.
Under this guarantee, free repair or replacement will be made to your satisfaction.**

For your nearest authorized Enerpac Service Center, visit us at www.enerpac.com

Enerpac, a unit of  Tools and Supplies.