

L1667

For date codes beginning with the letter "A".

Rev. O

03/97

PC5220

**INSTALL ALL KIT COMPONENTS TO INSURE OPTIMUM PERFORMANCE OF THE REPAIRED VALVE.**

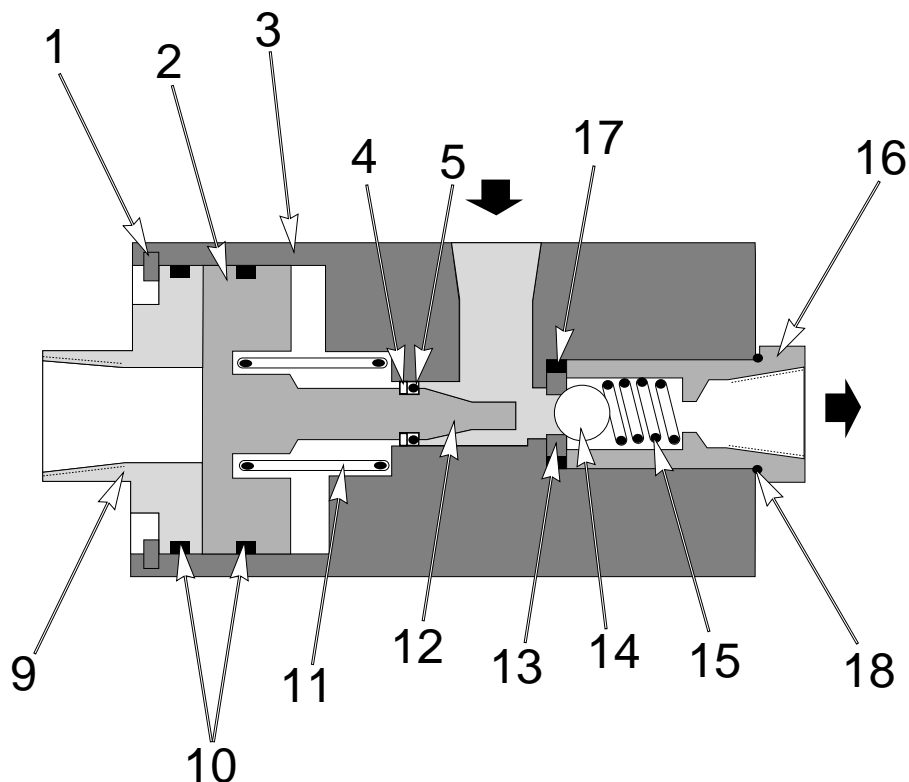

**REPAIR PARTS LIST FOR FIGURE 1**

Item	Part Number	Quantity	Description	Item	Part Number	Quantity	Description
1	402030	1	Retaining Ring	12	402026	1	Plunger
2	402341	1	Piston	13	★ 402055	1	Seat
3	402023	1	Body	14	B1008016	1	9/32" Ball
4	B1006564	1	Back-Up Washer	15	DA5100210	1	Conical Spring
5	★ B1001503	1	O-Ring	16	402054	1	Bushing
9	402340	1	Retainer	17	★ 300109	1	O-Ring
10	★ B1265503	2	O-Ring	18	★ B1906503	1	O-Ring
11	503625	1	Spring	20	DA5111126	1	Name Plate

★ Items included in and available only as part of Repair Kit HV1000AK.  
 Repair Kit also contains: o-ring 300131, seat 402219, and o-ring B1028503.

# SERVICE INSTRUCTIONS

Work on a clean bench and use lint free wipes.

## ■ Disassembly

1. Drain oil out of the pressure ports. Wipe off excess oil.
2. Remove retaining ring (1) and retainer (9).
3. Remove piston (2) by plugging the hydraulic outlet port and applying 10 psi of air pressure to the hydraulic inlet port. Use caution as the piston is forced out by the air pressure.
4. Remove spring (11).
5. Unscrew bushing (16). The ball (14) and spring (15) will come out with the bushing. Use a pick to remove the seat (13) and o-ring (17). Discard seat and o-ring.
6. Remove remaining o-rings (5, 10, 18) and discard.
7. Clean metal components with solvent and dry thoroughly using shop air.
8. Inspect all parts for wear. Replace as required.

## ■ Assembly

Assemble valve using parts from repair kit. Take care to avoid damaging plunger (12) and inside of body (3).

**NOTE:** If you need to replace the plunger (12), apply Loctite 290 to threads and torque to 28-34 ft-lbs.

1. Lubricate o-rings (5, 10, 17, 18) and install.
2. Coin and install seat (13).
3. Insert ball (14) and spring (15). Secure with bushing (16).
4. Insert spring (11), piston (2) and retainer (9). Secure with retaining ring.

### Australia

ENERPAC  
Applied Power Australia, Ltd.  
P.O. Box 261 Regents Park  
Sydney, N.S.W. 2143  
Tel: (61) (2) 9743 8988  
Fax: (61) (2) 9743 8648

### CIS

Applied Power Moscow  
Leninsky Prospekt 95A  
117313 Moscow, Russia  
Tel: (7)(95) 936 5090  
Fax: (7)(95) 936 2006

### France, Switzerland, Turkey, Greece, Africa, Middle East

ENERPAC S.A.  
Parc d'Activité du Moulin  
de Massy  
1 rue du Saule trapu, BP200  
F-91882 Massy CEDEX  
(Paris) France  
Tel: (33) 1 60 13 68 68  
Fax: (33) 1 69 20 37 50

### Germany, Scandinavia, Eastern Europe, Austria, Switzerland

ENERPAC  
Applied Power GmbH  
P.O. Box 30 01 13  
Mündelheimer Weg 51  
40401 Düsseldorf 30  
Germany  
Tel: (49) (211) 47 14 90  
Fax: (49) (211) 4714 928/940

### Holland, Belgium, and Luxembourg

ENERPAC B.V.  
P.O. Box 269, Storkstraat 25  
3900AG Veenendaal  
Holland  
Tel: (31) (318) 535911  
Fax: (31) (318) 525613/526645

**Hong Kong**  
ENERPAC  
Room No. 907, Workingberg  
Commercial Building  
41-47 Marble Road, North Point  
Tel: (852) 561-6295  
Fax: (852) 561-6772

### India

ENERPAC  
Hydraulics (India) Pvt Ltd.  
203 Vardhaman Chamber  
Plot #84, Sector 17  
Vashi, New Bombay 400 705  
India  
Tel: 91-22-7631062  
Fax: 91-22-7670309

### Italy

ENERPAC  
Applied Power Italiana S.p.A.  
Via Canova, 4  
20094 Corsico (Milano)  
Italy  
Tel: 39 2 45 82 741/2/3  
Fax: 39 2 48 60 12 88

### Japan

Applied Power Japan LTD  
10-17 Sasame Kita-cho  
Toda-City  
Saitama 335,  
Japan  
Tel: 81 048 422 2251  
Telex: J26275  
Fax: 81 048 422 0596

### Mexico

ENERPAC  
Applied Power Mexico S.A. de C.V.  
Av. Principal La Paz #100  
Fracc. Industrial La Paz  
42084 Pachuca. Hidalgo, Mexico  
Tel: (52) 771 33700  
Fax: (52) 771 83800

### Singapore

Applied Power Asia Pte Ltd.  
47 Jalan Pemimpin #01-02  
01-03 Sin Cheong Building  
Singapore 2057  
Thomson Road P.O. Box 114  
Singapore 9157  
Tel: (65) 258 1677  
Fax: (65) 258 2847

### South Korea

ENERPAC  
Applied Power Korea Ltd.  
163-12, Dodang-Dong  
Wonmi-gu, Buchun-Shi,  
Kyunggi-Do  
Korea  
Tel: (82) (32) 675 0836  
Fax: (82) (32) 675 3002

### Spain, Portugal

ENERPAC  
Applied Power International, S.A.  
Calle de la Imprenta, 7  
Polígono Industrial  
28100 Alcobendas (Madrid)  
Spain  
Tel: (34) 1 661 11 25  
Fax: (34) 1 661 47 89

### United Kingdom, Ireland

ENERPAC Ltd. Unit 3  
Colemeadow Road  
North Moons Moat  
Redditch, Worcester B98 9BP  
England  
Tel: 44 01527 598 900  
Fax: 44 01527 585 500

### United States, Canada, Latin America and Caribbean

ENERPAC  
13000 West Silver Spring Drive  
Butler, Wisconsin 53007, USA  
Tel: (414) 781-6600  
1-800-433-2766 (End User)  
1-800-558-0530 (Distributor)  
Fax: (414) 781-1049

### Canada

Tel: 1-800-426-4129 (End User)  
Tel: 1-800-426-2284 (Distributor)

### Latin America and Caribbean

Tel: (414) 781-6600 ext. 263  
Fax: (414) 781-5561



All Enerpac products are guaranteed against defects in workmanship and materials for as long as you own them. Under this guarantee, free repair or replacement will be made to your satisfaction.

For prompt service, contact your Authorized Enerpac Service Center or call toll free:

In U.S.A. 1-800-558-0530  
In Canada 1-800-426-2284