

▼ Shown left to right: PAMG1402N, PATG1102N, PARG1102N, PATG1105N



- High efficiency cast aluminum air motor for increased life and reduced air consumption
- Fully serviceable air motor assembly
- Reinforced heavy-duty reservoir for applications in tough environments
- New generation air-saver piston with rugged one-piece design reduces air consumption and operating costs
- Return-to-tank port for use in remote valve applications
- Quiet – only 76 dBA with low air consumption of 12 scfm
- Operating air pressure: 40-125 psi, enables pump to start at extremely low pressure
- Internal pressure-relief valve provides overload protection
- Mounting Bracket Kit (MTB1) available to mount pumps to horizontal or vertical surfaces

## Compact Air Over Hydraulic



### RFL102 Regulator-Filter-Lubricator

Recommended for use with all air pumps. Provides clean, lubricated air and allows for air pressure adjustment. Steel bowl guards are standard.

Order model number <sup>1)</sup>

**RFL102**



### Large Reservoir Models

The Turbo II Air Pump is also available with a larger reservoir: **PATG1105N**, **PAMG1405N**, and **PARG1105N**.



### Hoses

Enerpac offers a complete line of high-quality hydraulic hoses. To ensure the integrity of your system, specify only genuine Enerpac hydraulic hoses.

Page: 148

▼ Easily operated by hand or by foot.



Used with Cylinder	Usable Oil Capacity (in <sup>3</sup> )	Model Number
Single-acting	127	PATG1102N
	230	PATG1105N
	127	PARG1102N
	230	PARG1105N
Double-acting	127	PAMG1402N
	230	PAMG1405N

# Turbo II Air Hydraulic Pumps



The PATG-models use a foot or hand-operated treadle to control air and valve functions.

The PAMG-models use a treadle with a locking feature and a 4-way manual valve.

The PARG-models use a 15-ft. pendant hose for convenient one-man operation.

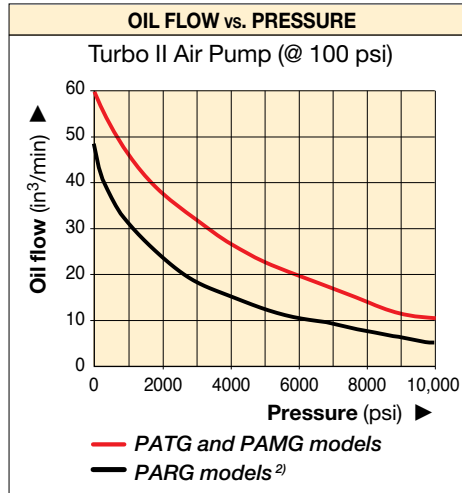

## PATG PARG PAMG Series



Reservoir Capacity:  
**150 - 305 in<sup>3</sup>**

Flow at Rated Pressure:  
**5 - 10 in<sup>3</sup>/min.**

Maximum Operating Pressure:  
**10,000 psi**

Pressure Rating (psi)	Output Flow Rate (in <sup>3</sup> /min)		Model Number	Valve Function	Air Pressure Range (psi)	Air Consumption (scfm)	Sound Level (dBA)
	No load	Load					
10,000	60	10	PATG & PAMG	Advance/	40-115	12	76
10,000	51 <sup>1)</sup>	6 <sup>1)</sup>					
10,000	48 <sup>2)</sup>	5 <sup>2)</sup>	PARG	Hold/ Retract	40-115	8	76

<sup>1)</sup> Air supply connected at pendant. <sup>2)</sup> Air supply connected at pump shown on flow curve.



### Speed Chart

To determine how an 8000-Series pump will operate your cylinder, see the Pump/Cylinder Speed Chart in the "Yellow Pages".

Page: 409

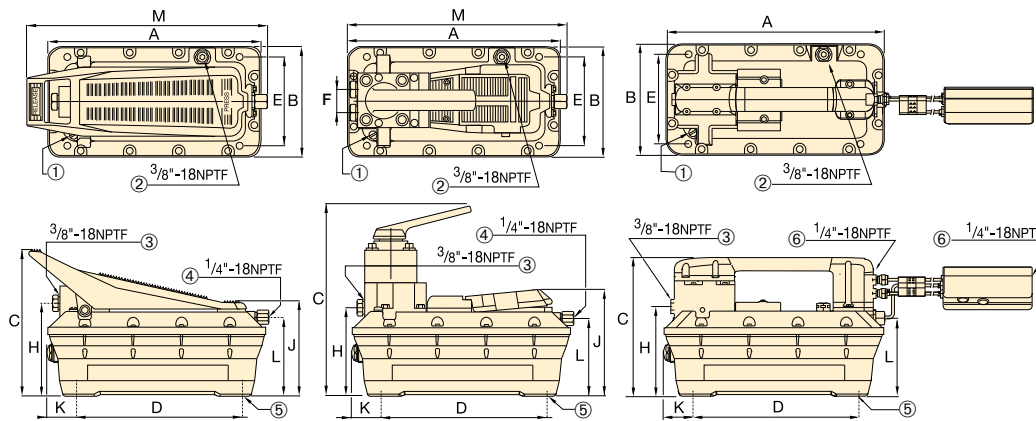

- ① Filtered "Permanent" Tank Vent
- ② Return-to-Tank/Auxiliary Vent/Fill Tank Port
- ③ Hydraulic Output
- ④ Swivel Air Input with Filter
- ⑤ 4 Mounting Holes for #10 thread forming screw. Max. depth into reservoir = 0.75"
- ⑥ Air Input Options

**PATG1102N**  
**PATG1105N**

**PAMG1402N**  
**PAMG1405N**

**PARG1102N**  
**PARG1105N**

Dimensions (in)											Weight (lbs)	Model Number
A	B	C	D	E	F	H	J	K	L	M		
12.33	6.49	8.29	9.04	4.00	—	5.15	5.75	1.65	4.43	13.62	18	<b>PATG1102N</b>
15.60	7.92	8.22	9.04	4.00	—	5.08	5.75	3.28	4.41	17.20	22	<b>PATG1105N</b>
12.33	6.49	7.88	9.04	4.00	—	5.15	—	1.65	4.43	—	22	<b>PARG1102N</b>
15.60	7.92	7.88	9.04	4.00	—	5.08	—	3.28	4.41	—	26	<b>PARG1105N</b>
12.33	6.49	10.50	9.04	4.00	1.42	5.23	6.00	1.65	4.43	12.60	24	<b>PAMG1402N</b>
15.60	7.92	10.50	9.04	4.00	1.42	5.19	6.00	3.28	4.41	15.94	28	<b>PAMG1405N</b>