

Specifications

Units:

Imperial

Metric

Maximum Operating Pressure (psi)	10,150
Capacity Class (tonnage)	100
Maximum Cylinder Capacity Advance (tons)	112.4
Maximum Cylinder Capacity Retract (tons)	63.8
Stroke (in)	5.91
Collapsed Height A (in)	13.92
Extended Height B (in)	19.83
Return Type	Double-Acting, Hydraulic Return
Plunger Type	Hollow
Material	Aluminum
Cylinder Effective Area Advance (in ²)	22.16
Cylinder Effective Area Retract (in ²)	12.57
Oil Capacity Advance (in ³)	130.79
Oil Capacity Retract (in ³)	74.19
Surface Treatment	Anodized
Coupler	CR400 Coupler

Dimensions

Units:

Imperial

Metric

Collapsed Height A (in)	13.92
Extended Height B (in)	19.83
Outside Diameter D (in)	9.25
Cylinder Bore Diameter E (in)	6.50
Plunger Diameter F (in)	5.12
Base to Advance Port H (in)	2.41
Saddle Diameter J1 (in)	4.97
Saddle Protrusion from Plunger K (in)	0.53
Plunger Internal Thread O (in)	4"-16 UN
Plunger Thread Length P (in)	1.06
Base Mounting Holes Bolt Circle U (in)	7.87
Base Mounting Holes Thread V	M10
Center Hole Diameter Y (in)	3.11
Base Mounting Holes Thread Depth Z (in)	0.47

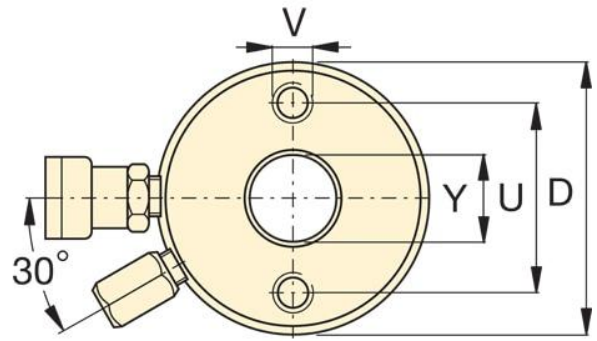
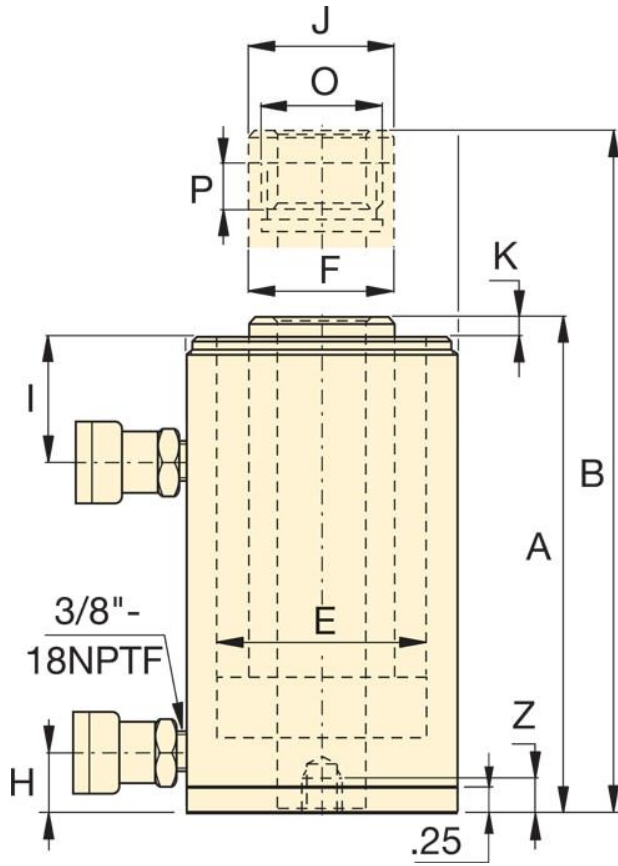

Dimensions shown in inches.