

Specifications

Units: Imperial Metric

Maximum Operating Pressure (psi)	10,150
Capacity Class (tonnage)	150
Maximum Cylinder Capacity Advance (tons)	167.2
Maximum Cylinder Capacity Retract (tons)	84.0
Stroke (in)	9.84
Collapsed Height A (in)	18.27
Extended Height B (in)	28.11
Return Type	Double-Acting, Hydraulic Return
Plunger Type	Hollow
Material	Aluminum
Cylinder Effective Area Advance (in ²)	32.96
Cylinder Effective Area Retract (in ²)	16.56
Oil Capacity Advance (in ³)	324.28
Oil Capacity Retract (in ³)	162.89
Surface Treatment	Anodized
Coupler	CR400 Coupler

Dimensions

Units: Imperial Metric

Collapsed Height A (in)	18.27
Extended Height B (in)	28.11
Outside Diameter D (in)	11.02
Cylinder Bore Diameter E (in)	7.48
Plunger Diameter F (in)	5.91
Base to Advance Port H (in)	2.41
Saddle Diameter J1 (in)	5.00
Saddle Protrusion from Plunger K (in)	0.74
Plunger Internal Thread O (in)	4 1/4"-12 UN
Plunger Thread Length P (in)	1.57
Base Mounting Holes Bolt Circle U (in)	9.84
Base Mounting Holes Thread V	M10
Center Hole Diameter Y (in)	3.11
Base Mounting Holes Thread Depth Z (in)	0.47

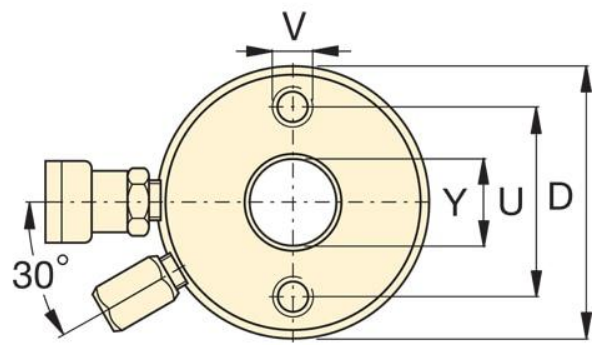
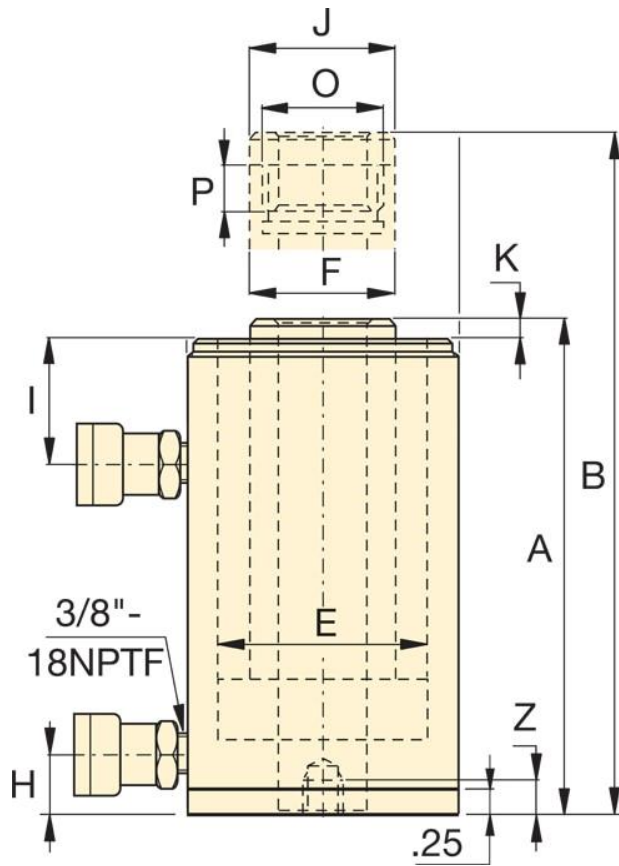

Dimensions shown in inches.