

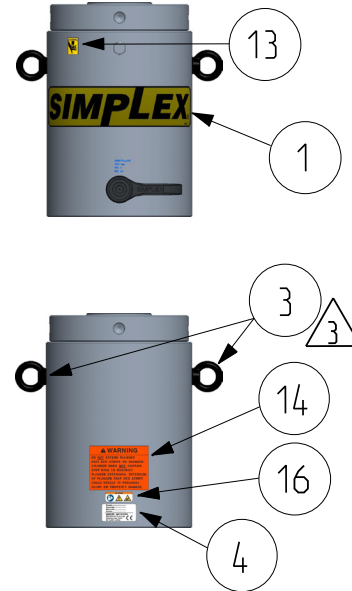

Repair Parts Sheet

RCL CYLINDERS, 100 TON MODELS

Parts Sheet Number	Revision	Revision Date	Product version
RRCL100	Rev. B	07/2020	A

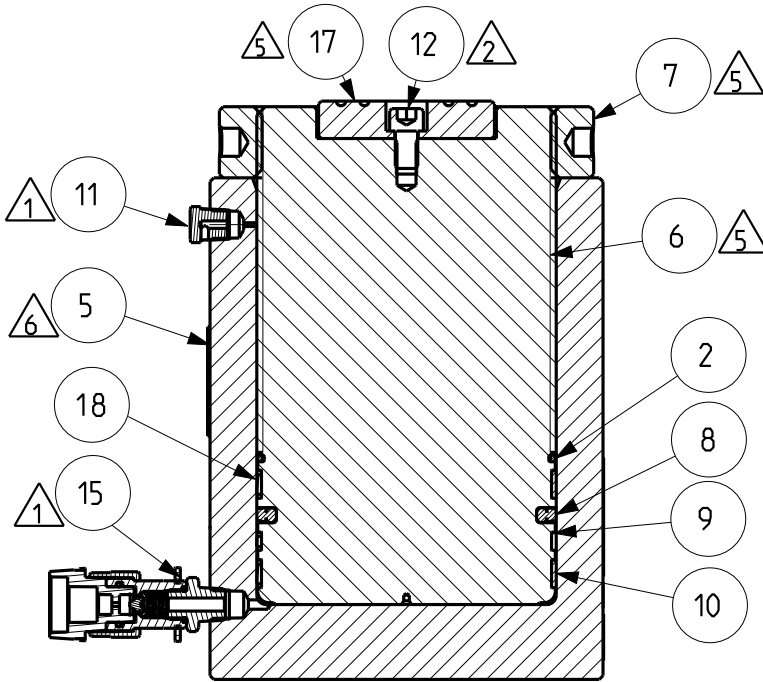

- ▲ = Indicated parts only available in Seal Kit RCL1002K
- = Indicated parts only available in Seal Kit RCL1006K
- = Indicated parts only available in Seal Kit RCL10012K

NOTES A:

- 1- Torque to 40-60 Ft-Lbs [55-81 Nm]
- 2- Torque to 15-25 Ft-Lbs [20-34 Nm]
- 3- Torque to 80-100 In-Lbs [9-11 Nm]
- 5- Apply oil wax before assembly
- 6- Apply oil wax after assembly

Nr.	DESCRIPTION	QTY	RCL1002	RCL1006	RCL10012
1	Simplex Decal	1	▲	■	●
2	O-Ring	1	▲	■	●
3	Eyebolt Rotating	2	24D0210	24D0210	24D0210
4	Characteristics Decal	1	▲	■	●
5	Base	1	52L0476	52L0447	52L0465
6	Plunger	1	53M0466	53M0437	53M0455
7	Nut	1	55L0260	55L0260	55L0260
8	Piston Seal	1	▲	■	●
9	Glide Ring-Piston	1	▲	■	●
10	Glide Ring-Piston	1	▲	■	●
11	Plug	1	BSS6349D	BSS6349D	BSS6349D
12	Screw-SHCS. HEX	1	CBE1221028-1A	CBE1221028-1A	CBE1221028-1A
13	Warning Decal	1	▲	■	●
14	Plunger Caution Warning Decal	1	▲	■	●
15	Female coupler	1	DB2771034	DB2771034	DB2771034
16	Caution Decal	1	▲	■	●
17	Saddle	1	HCL100045	HCL100045	HCL100045
18	Glide Ring-Piston	1	▲	■	●