

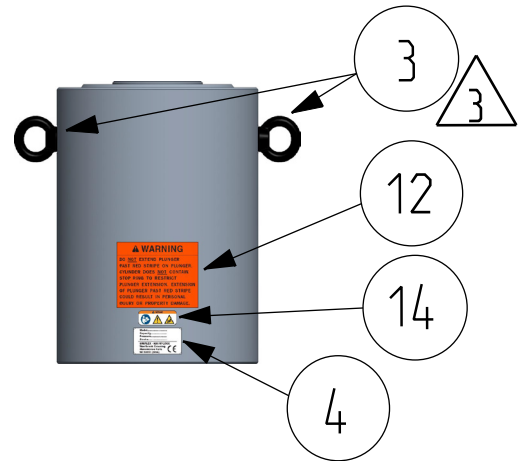

Repair Parts Sheet

RCX CYLINDERS, 150 TON MODELS

Parts Sheet Number	Revision	Revision Date	Product version
RRCX150	Rev. B	07/2020	A

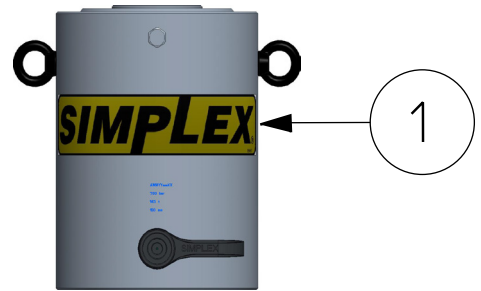
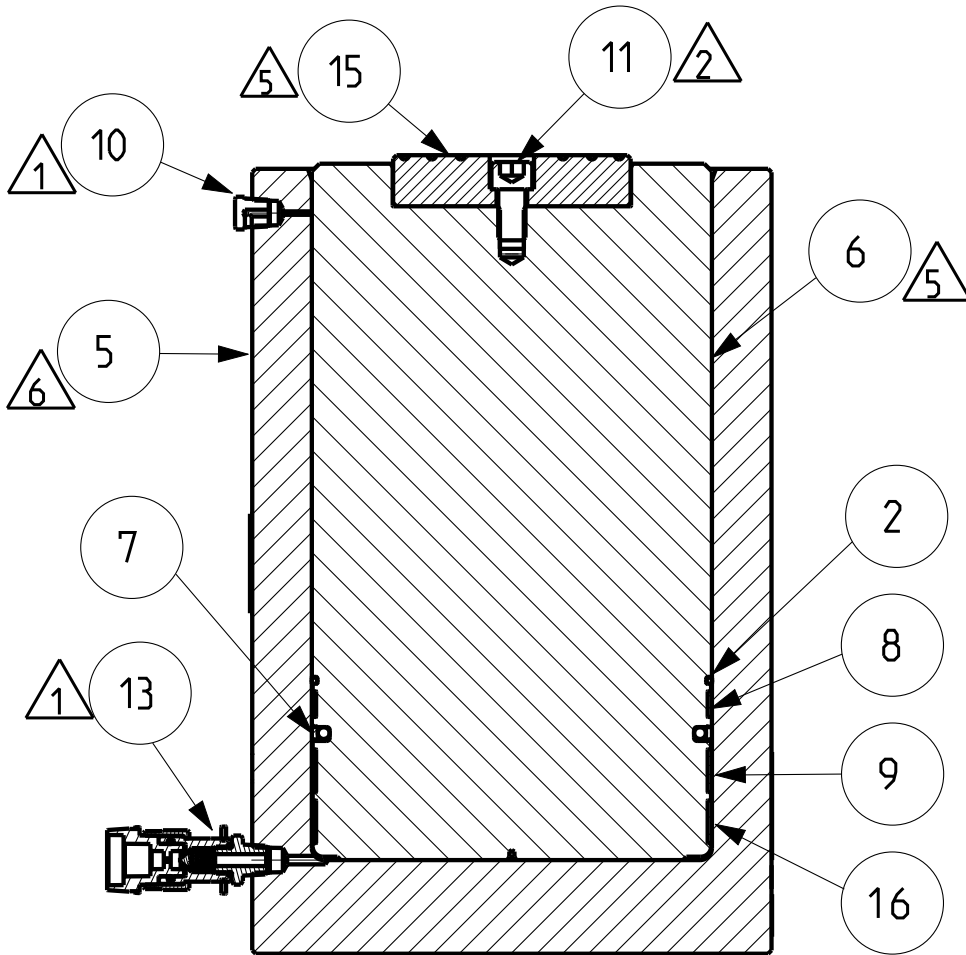

NOTES Δ:

- 1- Torque to 40-60 Ft-Lbs [55-81 Nm]
- 2- Torque to 15-25 Ft-Lbs [20-34 Nm]
- 3- Torque to 80-100 In-Lbs [9-11 Nm]
- 5- Apply oil wax before assembly
- 6- Apply oil wax after assembly

- ▲ = Indicated parts only available in Seal Kit RCX1502K
- = Indicated parts only available in Seal Kit RCX1506K
- = Indicated parts only available in Seal Kit RCX15012K

Nr.	DESCRIPTION	QTY	RCX1502	RCX1506	RCX15012
1	Simplex Decal	1	▲	■	●
2	O-Ring	1	▲	■	●
3	Eyebolt Rotating	2	24D0210	24D0210	24D0210
4	Characteristics Decal	1	▲	■	●
5	Base	1	52L0479	52L0481	52L0467
6	Plunger	1	53M0478	53M0477	53M0475
7	Piston Seal	1	▲	■	●
8	Glide Ring-Piston	1	▲	■	●

Nr.	DESCRIPTION	QTY	RCX1502	RCX1506	RCX15012
9	Glide Ring-Piston	1	-	■	●
10	Plug	1	BSS6349D	BSS6349D	BSS6349D
11	Screw-SHCS. HEX	1	CBE1221028-1A	CBE1221028-1A	CBE1221028-1A
12	Plunger Caution Warning Decal	1	▲	■	●
13	Female coupler	1	DB2771034	DB2771034	DB2771034
14	Caution Decal	1	▲	■	●
15	Saddle	1	HCR150045	HCR150045	HCR150045
16	Glide Ring-Piston	1	▲	■	●