

L4244 Rev. B 03/19

<i>Table of Contents:</i>	
<i>Section</i>	<i>Page</i>
1.0 IMPORTANT RECEIVING INSTRUCTIONS	1
2.0 SAFETY	1
3.0 CONFORMANCE TO NATIONAL AND INTERNATIONAL STANDARDS	3
4.0 PRODUCT DESCRIPTION	3
5.0 LIFTING THE CYLINDER	3
6.0 SETUP	4
7.0 AVOIDING SIDE LOAD	5
8.0 OPERATION	5
9.0 INSPECTION, MAINTENANCE & STORAGE	5
10.0 RELIEVING TRAPPED PRESSURE	5
11.0 TROUBLESHOOTING	5
12.0 PRODUCT DATA	7

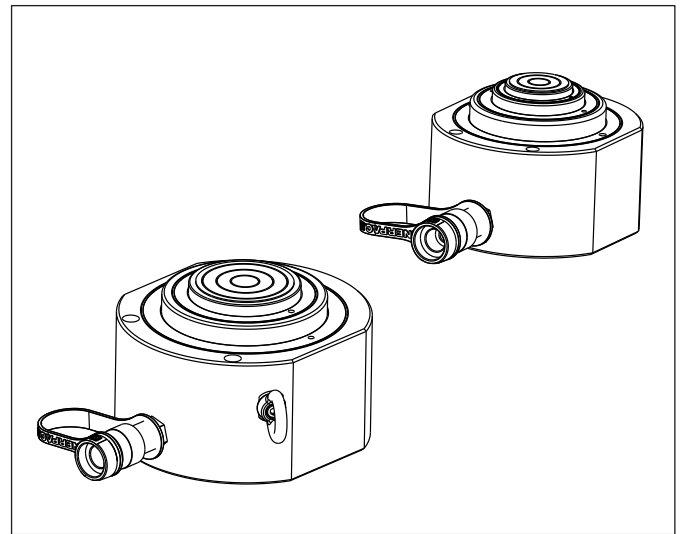

Safety Alert Symbols are used in conjunction with certain Signal Words that call attention to safety messages or property damage messages and designate a degree or level of hazard seriousness. The Signal Words used in this manual are WARNING, CAUTION and NOTICE.

1.0 IMPORTANT RECEIVING INSTRUCTIONS

Visually inspect all components for shipping damage. Shipping damage is not covered by warranty. If shipping damage is found, notify carrier at once. The carrier is responsible for all repair and replacement costs resulting from damage in shipment.

2.0 SAFETY

2.1 Introduction

Read all instructions carefully. Follow all recommended safety precautions to avoid personal injury as well as damage to the product and/or damage to other property. Enerpac cannot be responsible for any damage or injury from unsafe use, lack of maintenance or incorrect operation. Do not remove warning labels, tags, or decals. In the event any questions or concerns arise, contact Enerpac or a local Enerpac distributor for clarification.

If you have never been trained on high-pressure hydraulic safety, consult your distributor or service center for information about an Enerpac Hydraulic Safety Course.

This manual follows a system of safety alert symbols, signal words and safety messages to warn the user of specific hazards. Failure to comply with these warnings could result in death or serious personal injury, as well as damage to the equipment or other property.



The **Safety Alert Symbol** appears throughout this manual. It is used to alert you to potential physical injury hazards. Pay close attention to Safety Alert Symbols and obey all safety messages that follow this symbol to avoid the possibility of death or serious personal injury.



Indicates a hazardous situation that, if not avoided, **could** result in death or serious personal injury.



Indicates a hazardous situation that, if not avoided, **could** result in minor or moderate personal injury.



Indicates information considered important, but not hazard related (e.g. messages relating to property damage). Please note that the Safety Alert Symbol will **not** be used with this signal word.

2.2 Hydraulic Cylinder Safety Precautions (RLT-Series)



Failure to observe and comply with the following precautions could result in death or serious personal injury. Property damage could also occur.

- Read and completely understand the safety precautions and instructions in this manual before operating the cylinder or preparing it for use. Always follow all safety precautions and instructions, including those that are contained within the procedures of this manual.
- Operating procedures will vary, depending on the system arrangement. Always read, follow and completely understand all manufacturer's instructions when operating pumps, valves and all other devices used with the cylinders. Follow all safety precautions contained in the manufacturer's manuals.

- Always wear appropriate personal protective equipment (P.P.E.) when operating hydraulic equipment. Be sure to wear eye protection, work gloves and protective clothing. Use of additional P.P.E. safety items such as dust mask, non-skid safety shoes, hard hat, and hearing protection (used as appropriate for the conditions) will reduce the chance of personal injuries. The use of these items may also be required by local regulations or laws.
- Do not handle pressurized hoses. Escaping oil under pressure can penetrate the skin. If oil is injected under the skin, see a doctor immediately.
- Do not pressurize disconnected couplers.
- Use hydraulic cylinders only in a coupled system. Never use a cylinder with uncoupled couplers.
- Do not remove or disable the pump relief valve.
- Do not remove or disable the cylinder relief valve (if equipped).
- The system operating pressure must not exceed the pressure rating of the lowest rated component in the system.
- Install pressure gauge(s) in the system to monitor operating pressure. It is your window to see what is happening in the system.
- Never set a relief valve to a higher pressure than the maximum rated pressure of the pump and cylinder. If ratings are different, relief valve setting should not exceed the setting of the lowest rated component (pump or cylinder).
- The RLT-Series cylinders are designed for a maximum working pressure of 10,150 psi [700 bar]. Do not connect a pump with a higher pressure rating to these cylinders.
- Do not exceed equipment ratings. Never attempt to lift a load weighing more than the rated capacity of the cylinder. Overloading may cause equipment failure and possible personal injury.
- Be sure setup is stable before lifting load. Cylinders should be located on a firm and level surface capable of supporting the full load.
- Where applicable, use a cylinder base plate to provide added stability. If desired, the cylinder can be bolted to the base plate, using the bolt holes in the cylinder base.
- Do not weld, drill or otherwise modify a cylinder to attach a base plate or other support unless approved in writing by the Enerpac Engineering Department. Use only the provided bolt holes.
- Always perform a visual inspection of the cylinder before placing it into operation. If any problems are found, do not use the cylinder. Have the cylinder repaired and tested by an Enerpac Authorized Service Center before it is returned to service.
- Never use a cylinder that is leaking oil. Do not use a cylinder that is damaged, altered or in need of repair.
- Always lift the cylinder using a hoist, crane or other suitable lifting device of sufficient rated capacity. On models equipped with a lifting eye, use only the supplied lifting eye to attach the cylinder to the lifting device. Replace lifting eye if damaged or missing.
- Allow only trained and experienced personnel to supervise and perform lifting and lowering procedures.
- Be certain that no persons are working on or near any cylinders before lifting or lowering of the load begins. Alert all personnel in advance that lifting or lowering is about to occur.
- Use suitable cribbing of rigid construction to hold loads.
- Never use a hydraulic cylinder as a shim or spacer in any lifting or pressing application.
- A cylinder when used as a load lifting device, should never be used as a load holding device. After the load has been raised or lowered, it always must be cribbed mechanically.
- Be certain that the load is centered and covers the entire plunger saddle surface. Otherwise, the load may slip or fall, causing potential danger.
- Lift only dead weight loads. Avoid lifting live weight loads.
- Be especially careful when lifting loads such as partially filled storage tanks, in which the center of gravity could move or shift during lifting. Be aware that the distribution of some loads can change quickly and without warning.
- Do not use the cylinder to lift people. Do not allow people to be on top of the load during lifting or lowering.
- Keep all personnel clear of the work area while lifting or lowering is in progress. To avoid personal injury, keep hands and feet away from cylinder and load during operation.
- Maintain communication with the operator at all times Use hand signals, two-way radios or other appropriate forms of communication if the load is not visible to the operator.
- Operate pump and valve as required to ensure that the load is lifted and lowered evenly and at a controlled rate.
- Closely watch the load at all times during lifting and lowering. Stop lifting or lowering immediately if the load becomes unstable or appears to be lifting or lowering unevenly.
- Stay clear of loads supported only by hydraulics. As required, follow the lifted load with cribbing.
- Always be certain that hydraulic pressure is fully relieved and that the load is fully removed from the cylinder(s) before disconnecting hydraulic hoses, loosening hydraulic fittings, or performing any cylinder disassembly or repair procedures.
- Enerpac does not recommend the use of multiple telescopic cylinders with the SFP Series pump. In a multi-point application, the plunger stages of each telescopic cylinder will extend and retract at slightly different speeds. The cylinders will never be exactly synchronized and uneven lifting will result.

CAUTION

Failure to observe and comply with the following precautions could result in minor or moderate personal injury. Property damage could also occur.

- Be careful to avoid damaging hydraulic hoses. Avoid sharp bends and kinks when routing hydraulic hoses. Do not exceed the minimum bend radius specified by the hose manufacturer. Using a bent or kinked hose will cause severe back-pressure. Sharp bends and kinks will internally damage the hose, leading to premature hose failure.
- Do not drop heavy objects on hoses. A sharp impact may cause internal damage to hose wire strands. Applying pressure to a damaged hose may cause it to rupture.
- Do not lift hydraulic equipment by the hoses or couplers. Use the cylinder lifting eyes and appropriately rated lifting equipment.
- Keep hydraulic equipment away from flames and heat. Excessive heat will soften packings and seals, resulting in fluid leaks. Heat also weakens hose materials and packings.
- For optimum performance, do not expose hydraulic equipment to temperatures of 150°F [65°C] or higher. Protect all hydraulic equipment from weld spatter.
- Immediately replace worn or damaged parts with genuine Enerpac parts. Non-Enerpac parts may break or cause the product to malfunction.

NOTICE

- Hydraulic equipment must only be serviced by a qualified hydraulic technician. For repair service, contact the Enerpac Authorized Service Center in your area.
- To help ensure proper operation and best performance, use of Enerpac oil is strongly recommended.

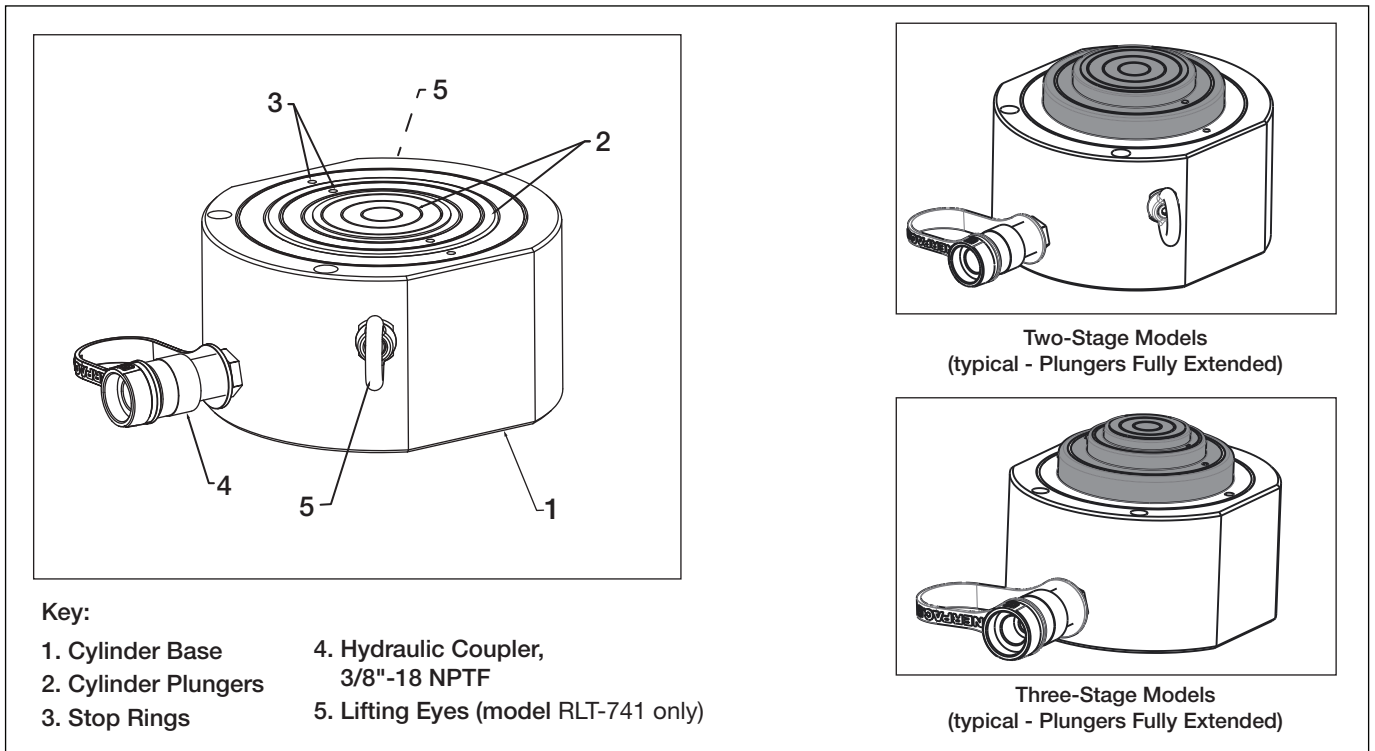

Figure 1, Major Features and Components, RLT-Series Hydraulic Cylinders (Typical)

2.3 Additional References

Consult the applicable industry and/or government standards in your country or region for additional safety precautions and work rules applicable to hydraulic cylinders, jacks and other similar lifting equipment.

In the USA, refer to the following publications:

- Code of Federal Regulations - Title 29 Occupational Safety and Health Standards (U.S. Government Publishing Office, 732 North Capitol Street, NW, Washington, DC 20401-0001. www.gpo.gov).
- ASME B30.1 Standards - Jacks (American Society of Mechanical Engineers, Two Park Avenue, New York, NY 10016-5990. www.asme.org).

In the European Union, refer to the standards and directives listed in the product's EU Declaration of Incorporation. A copy of this document is packed separately with the cylinder.

3.0 CONFORMANCE TO NATIONAL AND INTERNATIONAL STANDARDS

CE Enerpac declares that this product has been tested and conforms to applicable standards and is compatible to all CE Requirements. A copy of an EU Declaration of Incorporation is enclosed with each shipment of this product.

4.0 PRODUCT DESCRIPTION

Enerpac RLT-Series multi-stage telescopic cylinders are an ideal solution for a wide variety of industrial lifting applications where a relatively long stroke and low collapsed height is required.

All RLT-Series models are single-acting with hydraulic advance and load return. Manual force or a pump equipped with a vacuum valve will be required to retract the plunger if no load is present.

Capacities range from 12.5 to 158.2 US tons [111 to 1,407 kN] on first stage. Each model has different capacities on first, second and third stages (where applicable). Refer to the product data markings on the cylinder base for the capacity rating of your cylinder model. Also refer to the tables in sections 12.1 and 12.2 of this manual.

All standard production RLT-Series cylinders are designed for 10,150 psi [700 bar] maximum working pressure.

Refer to Section 12 of this manual for cylinder weights, oil volumes, dimensions and additional specifications.

5.0 LIFTING THE CYLINDER

Cylinder model RLT-741 is equipped with two pre-installed lifting eyes. Always use these lifting eyes when hoisting the cylinder. Lifting straps or chains must be positioned at an angle where they will not interfere with the cylinder base. Use of a spreader bar is recommended. See Figure 2.

The other RLT-Series cylinder models are not equipped with lifting eyes.

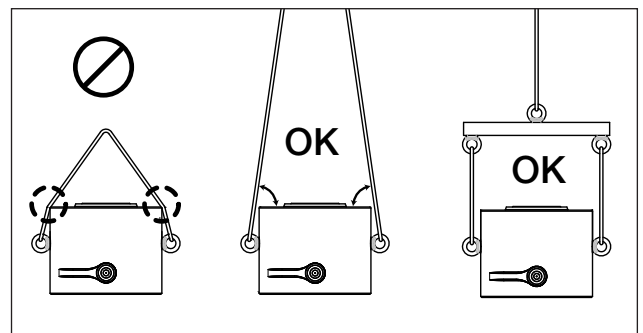

Figure 2, Lifting Arrangements (typical - model RLT-741)

6.0 SETUP

6.1 Hydraulic Pump Requirements

Hydraulic pumps are sold separately and are not included with the cylinders.

A hand-operated hydraulic pump can be used to operate an RLT-Series cylinder. However, a series of coupled cylinders will typically require the use of an electric, air or gas powered hydraulic pump.

Whichever type of pump is used, be certain that the pump reservoir is capable of holding a sufficient amount of hydraulic oil to operate the cylinder (or set of cylinders) to full extension.

The pump must be equipped with a suitable directional control valve or pressure release valve, designed for use with single acting cylinders. This valve may be either manual or remote operated.

The pump must also be equipped with a separate safety pressure relief valve that opens if the system working pressure exceeds 10,150 psi [700 bar]. Verify that the pump safety relief valve is adjusted to the proper setting before using the pump with the cylinder(s).

6.2 Hydraulic Oil Requirements

Use of Enerpac HF Series ISO 32 hydraulic oil is recommended. Enerpac HF oil is available at your local Enerpac Distributor or Authorized Service Center.

NOTICE

- Failure to use the correct oil type (high-quality ISO 32 hydraulic oil) may result in damage to cylinder hydraulic components and will void the product warranty.
- Be sure that the oil is clean. The oil cleanliness should be maintained to a maximum level of 18/16/13 per the ISO 4406 standard. If the oil develops a milky, cloudy or dark appearance, it should be changed immediately.
- To avoid overfilling and possible equipment damage, add oil to the pump reservoir only after all cylinder plungers are completely retracted and system pressure is released.
- When using a hand-operated pump to power the cylinder(s), it is permissible to use a high-quality brand of ISO 15 hydraulic oil. The lower oil viscosity will result in reduced pumping effort, especially in cold weather conditions.

6.3 Hydraulic Connections

All RLT-Series cylinders are equipped with one 3/8"-18 NPTF female coupler. This coupler provides hydraulic flow for both advance and retract functions.

Refer to Figure 1, item 4 for location.

Be certain that couplers are fully connected, so that hydraulic flow is not blocked or restricted.

All hoses, fittings and other hydraulic components in the circuit must be rated for at least 10150 psi [700 bar] operation.

6.4 Air Removal

Trapped air must be removed from the hydraulic cylinder and hose before placing the system into operation. If multiple cylinders are to be used, it is recommended that air be removed from each cylinder individually. Refer to the following procedure:

1. Position the pump so it is located *higher* than the cylinder.
2. Place the cylinder in the vertical position, with the base located on a flat and level surface. Be sure that there is no load on the plunger.

3. Using the hydraulic pump and valve, advance and retract the plunger as required to remove trapped air:
 - a. Fully advance the plunger, being careful to avoid pressure build-up at full extension.
 - b. Completely relieve hydraulic pressure, then manually push the plunger into the cylinder base until it is fully retracted.
 - c. Repeat steps 3a and 3b until the plunger advances smoothly. Use of a hydraulic pump equipped with a vacuum valve will help aid plunger retraction.
4. Fully retract the plunger after completing air removal procedures. Check oil level in pump hydraulic reservoir. Add oil if oil level is low.
5. Repeat steps 1 through 4 for all cylinders to be used in the hydraulic circuit.

6.5 Cylinder Base Support

Be certain to provide adequate support for the cylinder base. RLT-Series cylinders require a flat and stable lifting surface that is capable of supporting the load without settling. A steel plate or steel bars of appropriate size should be placed between the cylinder base and the ground or other lifting surface. See Figure 3.

CAUTION Use of RLT-Series cylinders on surfaces such as sand, mud or dirt may result in loss of load and/or damage to cylinder.

Base mounting holes are provided on all models. Refer to Section 12 for mounting hole locations and dimensions. Mounting bolts are not included with the cylinder and must be provided by the user.

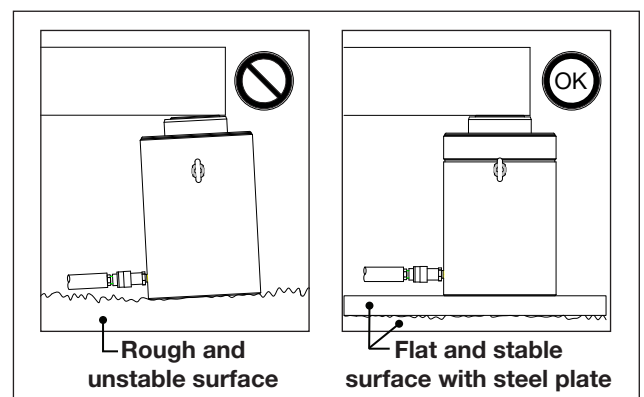

Figure 3, Cylinder Base Support

7.0 AVOIDING SIDE LOAD

Plan ahead to eliminate the presence of side load forces (offset loading) when using hydraulic cylinders. Side load can occur as a result of one or more of the following conditions:

- An eccentric load on the plunger.
- A horizontal load on a structure.
- A shifting center of gravity.
- Structure and/or cylinder misalignment.
- Non-synchronized lifting actions.
- Non-stable cylinder base support.

It is understood that some side load will occur in many lifting situations. However, the user should do everything possible to minimize or eliminate this condition.

The possibility of side load can be reduced by ensuring that the cylinder base is located on a flat and hard surface, capable of supporting the cylinder and the load without settling.

8.0 OPERATION

Operation procedures will vary, depending on hydraulic pump type, valve configuration and other factors. For detailed operating instructions and related information, refer to the instruction sheet included with your pump. Also follow the additional instructions and precautions contained in sections 8.1 and 8.2 of this manual.

If using multiple RLT-Series cylinders: Without load, verify that all plungers advance when the control valve is shifted to the advance position.

NOTICE It is mandatory that the operator has a full understanding of all instructions, safety precautions and applicable safety regulations before operating any high force hydraulic equipment. If questions or concerns, contact your local Enerpac Distributor or Authorized Service Center.

8.1 To Advance the Cylinder

Operate pump and valve so that oil flow is directed at a controlled rate from the pump reservoir to the cylinder coupler.

8.2 To Retract the Cylinder

Operate pump and valve so that oil flow is directed at a controlled rate from the cylinder coupler back to the pump reservoir. Note that additional hydraulic components may be required to control the rate at which the plunger retracts under load.

NOTICE RLT-Series cylinders contain no plunger return spring. External force will be required to fully retract an RLT-Series cylinder if it is not under load. Use of a hydraulic pump equipped with a vacuum valve will help aid cylinder retraction.

9.0 INSPECTION, MAINTENANCE & STORAGE

- Periodically check the hydraulic system for loose connections leaks and obvious problems. Replace any damaged components immediately.
- Monitor the oil temperature during operation. Do not exceed oil temperatures above 150°F [65°C].
- Install dust caps and plugs after disconnecting hydraulic hose from cylinder.
- Keep all hydraulic components clean.
- Change the hydraulic oil at the recommended interval shown in the pump instruction sheet. Change the hydraulic oil immediately if contamination is suspected.
- Store cylinders in the upright position, in a clean, dry and secure location. Keep stored cylinders and hoses away from heat and direct sunlight.
- If repairs are required, refer to the Enerpac website for the repair parts sheet applicable to your cylinder model.

NOTICE Hydraulic equipment must only be serviced by a qualified hydraulic technician. For repair service, contact the Enerpac Authorized Service Center in your area.

10.0 RELIEVING TRAPPED PRESSURE

Hydraulic pressure can sometimes become trapped within a hydraulic cylinder. This condition can occur in both single and double-acting cylinders, but is most likely to happen in a double-acting cylinder that has been exposed to changing ambient temperatures.

A common indication of trapped pressure is when mating hose and cylinder couplers will not engage, or are unusually difficult to engage.

If a trapped pressure condition is suspected, always use the Enerpac model CT-604 coupler bleed tool (available from your Enerpac distributor) to safely relieve any remaining pressure.

WARNING Never attempt to relieve trapped hydraulic pressure within the cylinder by loosening a coupler on the cylinder base.

Trapped hydraulic pressure can cause a loosened coupler to dislodge unexpectedly with great force. Serious personal injury or death will result if the coupler becomes a projectile and strikes persons working in the area.

A sudden escape of pressurized hydraulic oil may also occur if a coupler is loosened while trapped hydraulic pressure is present. Serious personal injury or death could result if a high pressure oil stream penetrates the skin.

Use only the Enerpac CT-604 coupler bleed tool to relieve trapped hydraulic pressure within the cylinder.

WARNING Never use a hammer and punch (or other similar method) to unseat a coupler check ball that is under pressure. Serious personal injury or death could result due to the sudden and uncontrolled escape of high pressure oil. Use only the Enerpac CT-604 coupler bleed tool to relieve trapped pressure within the cylinder.

11.0 TROUBLESHOOTING

Refer to the troubleshooting guide when diagnosing cylinder operational problems. Please note that the troubleshooting guide is not all-inclusive, and should be considered only as an aid to help diagnose the most common possible problems.

For repair service, contact your nearest Enerpac Authorized Service Center. As required, also refer to the troubleshooting information provided with your hydraulic pump or power unit.

Troubleshooting Guide

Symptom	Possible Cause	Solution
1. Plunger will not advance.	a. Pump release valve open.	Close pump release valve.
	b. Directional control valve not in proper position.	Shift directional control valve to proper position.
	c. Coupler not fully tightened.	Tighten coupler.
	d. Pump oil level is low.	Add oil to pump reservoir as required. See Section 6.2.
	e. Pump malfunctioning.	Repair or replace pump as required.
	f. Cylinder load rating too low for application.	Use a cylinder with a higher load rating.
	g. Cylinder seals leaking.	Repair or replace cylinder.
2. Plunger advances only part way.	a. Oil level in pump is low.	Add oil to pump reservoir as required. See Section 6.2.
	b. Coupler is not fully tightened.	Tighten coupler.
	c. Cylinder plunger binding.	Repair or replace cylinder.
3. Plunger advances erratically.	a. Air in hydraulic system.	Remove air from hydraulic system. See Section 6.4.
	b. Cylinder plunger binding.	Repair or replace cylinder.
4. Plunger advances more slowly than normal.	a. Leaking connection.	Repair leaking connection.
	b. Coupler not fully tightened.	Tighten coupler.
	c. Pump malfunctioning.	Repair or replace pump as required.
5. Plunger advances, but will not hold.	a. Pump malfunctioning.	Repair or replace pump as required.
	b. Leaking connection.	Repair leaking connection.
	c. Incorrect system set-up.	Check hose connections at pump and cylinders.
	d. Cylinder seals leaking.	Repair or replace cylinder.
6. Cylinder leaks oil.	a. Worn or damaged cylinder seals.	Repair or replace cylinder.
	b. Internal cylinder damage.	Repair or replace cylinder.
	c. Loose connection.	Tighten or repair connection.
7. Plunger will not retract or retracts more slowly than normal.	a. Pump release valve closed.	Open pump release valve.
	b. Directional control valve not in proper position.	Shift directional control valve to proper position.
	c. No load or insufficient load on plunger.	Manually retract the plunger (Note: RLT-Series cylinders are not equipped with spring return).
	c. Pump reservoir is overfilled.	Drain oil from pump reservoir as required.
	d. Improper hose connections.	Check hose connections.
	e. Narrow hose restricting oil flow.	Replace with larger diameter hose.
	f. Internal cylinder damage.	Repair or replace cylinder.

12.0 PRODUCT DATA

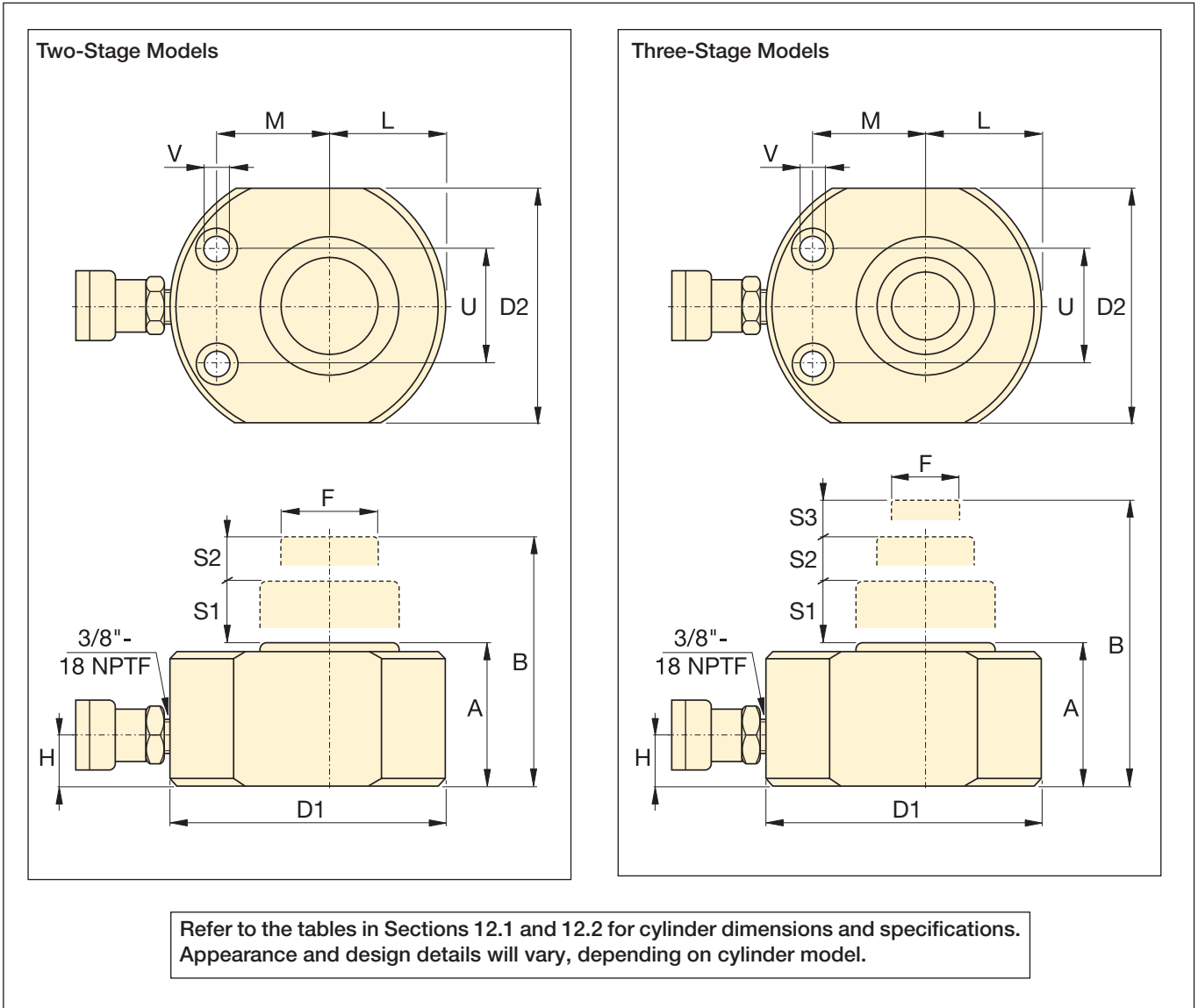

Figure 4, Dimensions, RLT-Series Cylinders

12.1 Dimensions and Specifications, RLT-Series Cylinders (imperial)

Refer to Figure 4 for dimensions graphic.

Cylinder Model Number	Collapsed Height	Extended Height	Outside Diameter		Plunger Diameter	Bottom to Advance Port	Plunger to Base	Plunger to Mtg. Hole	Oil Capacity	Weight
	A	B	D1	D2	F	H	L	M		
	in	in	in	in	in	in	in	in	in ³	lb
RLT-40	1.77	2.44	3.27	2.20	0.98	0.79	1.14	1.30	1.29	4
RLT-41	2.13	3.03	4.02	3.15	0.98	0.79	1.61	1.54	3.09	7
RLT-110	2.15	2.85	4.02	3.15	1.50	0.79	1.61	1.54	2.90	7
RLT-111	3.50	5.08	6.50	5.51	1.50	0.98	2.78	2.60	14.71	29
RLT-230	2.95	4.02	5.51	4.49	2.24	0.79	2.28	2.20	9.15	17
RLT-231	3.78	5.04	7.01	6.38	2.24	1.14	3.50	2.76	18.50	38
RLT-311	3.50	4.65	6.50	5.51	2.36	0.98	2.78	2.60	13.64	29
RLT-501	3.78	4.80	7.01	6.38	3.07	1.14	3.50	2.76	17.29	38
RLT-741	4.49	5.51	8.50	1.72	3.74	1.38	4.25	3.07	25.97	67

Cylinder Model Number	Mounting Hole Dimensions					
	Bolt Distance		Hole Diameter		Counter Bore Diameter	Counter Bore Depth
	U	V				
	in	in	in		in	
RLT-40	1.46	0.26			0.43	0.28
RLT-41	1.97	0.35			0.55	0.35
RLT-110	1.97	0.35			0.55	0.35
RLT-111	2.99	0.51			0.79	0.51
RLT-230	2.64	0.51			0.79	0.51
RLT-231	2.99	0.26			0.43	0.28
RLT-311	2.99	0.51			0.79	0.51
RLT-501	2.99	0.26			0.43	0.28
RLT-741	4.61	0.35			0.55	0.35

Cylinder Model Number	Capacity at Max. Stroke	Max Stroke	First Stage		Second Stage		Third Stage	
			S1		S2		S3	
			Capacity	Stroke	Capacity	Stroke	Capacity	Stroke
			US ton	in	US ton	in	US ton	in
RLT-40	4.8	0.67	12.5	0.43	4.8	0.24	-	-
RLT-41	4.8	0.91	26.1	0.43	12.5	0.28	4.8	0.20
RLT-110	12.5	0.71	26.1	0.43	12.5	0.28	-	-
RLT-111	12.5	1.57	81.7	0.63	34.8	0.51	12.5	0.43
RLT-230	26.1	1.06	55.8	0.63	26.1	0.43	-	-
RLT-231	26.1	1.26	104.4	0.63	55.8	0.39	26.1	0.24
RLT-311	34.8	1.14	81.7	0.63	34.8	0.51	-	-
RLT-501	55.8	1.02	104.4	0.63	55.8	0.39	-	-
RLT-741	81.7	1.02	158.2	0.63	81.7	0.39	-	-

First Stage: maximum load capacity at lowest maximum stroke.
Second Stage: extended stroke but at lower maximum capacity than the first stage.
Third Stage: maximum stroke extension but lowest maximum capacity.

12.2 Dimensions and Specifications, RLT-Series Cylinders (metric)

Refer to Figure 4 for dimensions graphic.

Cylinder Model Number	Collapsed Height	Extended Height	Outside Diameter		Plunger Diameter	Bottom to Advance Port	Plunger to Base	Plunger to Mtg. Hole	Oil Capacity	Weight
	A	B	D1	D2	F	H	L	M		
	mm	mm	mm	mm	mm	mm	mm	mm	cm ³	kg
RLT-40	45.0	62.0	83	56	25	20	29.0	33	21	1.8
RLT-41	54.0	77.0	102	80	25	20	41.0	39	51	3.1
RLT-110	54.5	72.5	102	80	38	20	41.0	39	48	3.0
RLT-111	89.0	129.0	165	140	38	25	70.5	66	241	13.1
RLT-230	75.0	102.0	140	114	57	20	58.0	56	150	7.6
RLT-231	96.0	128.0	178	162	57	29	89.0	70	303	17.3
RLT-311	89.0	118.0	165	140	60	25	70.5	66	224	13.0
RLT-501	96.0	122.0	178	162	78	29	89.0	70	283	17.3
RLT-741	114.0	140.0	216	196	95	35	108.0	78	426	30.4

Cylinder Model Number	Mounting Hole Dimensions				
	Bolt Distance		Hole Diameter	Counter Bore Diameter	Counter Bore Depth
	U	V			
	mm	mm	mm	mm	
RLT-40	37	6.5	11.0	7	
RLT-41	50	9.0	14.0	9	
RLT-110	50	9.0	14.0	9	
RLT-111	76	13.0	20.0	13	
RLT-230	67	13.0	20.0	13	
RLT-231	76	6.5	11.0	7	
RLT-311	76	13.0	20.0	13	
RLT-501	76	6.5	11.0	7	
RLT-741	117	9.0	14.0	9	

Cylinder Model Number	Capacity at Max. Stroke		Max Stroke	First Stage			Second Stage			Third Stage		
				S1			S2			S3		
	Capacity	Stroke		Capacity	Stroke		Capacity	Stroke				
	t	kN	mm	t	kN	mm	t	kN	mm	t	kN	mm
RLT-40	4.4	43	17	11.4	111	11	4.4	43	6	-	-	-
RLT-41	4.4	43	23	23.7	232	11	11.4	111	7	4.4	43	5
RLT-110	11.4	111	18	23.7	232	11	11.4	111	7	-	-	-
RLT-111	11.4	111	40	74.1	727	16	31.5	309	13	11.4	111	11
RLT-230	23.7	232	27	50.6	496	16	23.7	232	11	-	-	-
RLT-231	23.7	232	32	94.7	929	16	50.6	496	10	23.7	232	6
RLT-311	31.5	309	29	74.1	727	16	31.5	309	13	-	-	-
RLT-501	50.6	496	26	94.7	929	16	50.6	496	10	-	-	-
RLT-741	74.1	727	26	143.5	1,407	16	74.1	727	10	-	-	-

First Stage: maximum load capacity at lowest maximum stroke.

Second Stage: extended stroke but at lower maximum capacity than the first stage.

Third Stage: maximum stroke extension but lowest maximum capacity.

ENERPAC 
www.enerpac.com