



- Capacity▶ 20 tons
- Travel Range▶ 14 - 38 in.
- Barrel Range▶ 18 - 42 in.
- Weight▶ 57 - 92 lbs.

- ▶ 20 ton capacity models are used for connecting river barges, pulling forms and steel plates.
- ▶ Ideal for bridge construction and steel engineering projects.
- ▶ Equipped with spring activated pawl and 26 in. integrated handle.
- ▶ Can be used in “push” or “pull” applications.

SER20 & SER30 Shown



CE COMPLIANT

Our Jack design specifications meet or exceed ANSI /ASME B30.1 Safety Standards.



THINK SAFETY

Please refer to pages 4&5 for a complete list of safety tips and recommendations.

Mechanical Jacks

The Loadbinder Jack was used to tie in the sections of this platform. ▼

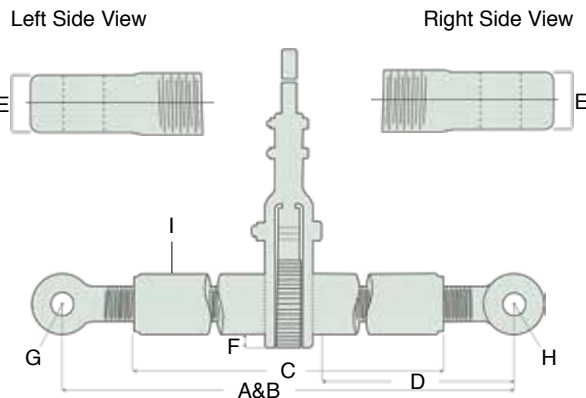
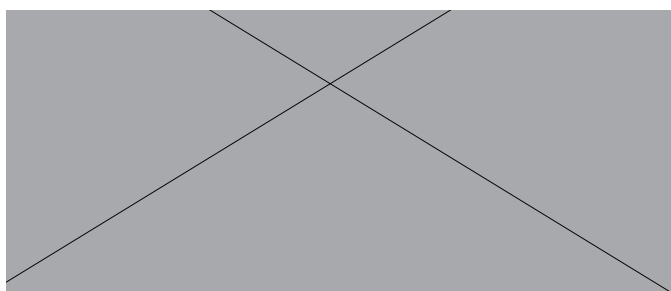

Model	Travel Length (in)	Screw Diameter (in)	Dimensions (in)									Weight (lbs)
			Eye to Eye		Barrel Length	Left / Right Screw Length	Left / Right Screw Eye Thickness	Ratchet Socket Length	Inner Diameter Left / Right Screw Eye	Radius	Pipe Barrel Outside Diameter	
			Minimum	Maximum								
SER10	14	2	23	37	18	11	1.87	.75	1.31	1.75	3.5	57
SER20	20	2	29	49	24	14	1.87	.75	1.31	1.75	3.5	66
SER30	26	2	35	61	30	17	1.87	.75	1.31	1.75	3.5	74
SER40	38	2	47	85	42	23	1.87	.75	1.31	1.75	3.5	92